

S O C I A L D E S I G N F O R R E A L L I F E



S T I L E

S O C I A L D E S I G N F O R R E A L L I F E



S T I L E

010 STILE
014 HEADQUARTER

032 VITAUROBANA
066 BENCHES
354 PICNIC AREA
386 LITTER BINS
532 BIKE RACKS
592 BOLLARDS AND BARRIERS
666 PLANTERS
708 DRINKING FOUNTAINS
672 TREE-GRILLES
740 DIS LA S A DS
776 SHELTERS
782 COVERAGES
832 LA RO DS

866 METALCO 1984 FATTO SU MISURA

900 DRAWINGS / PLANS

970 A ERIALS A D REA E S

032 VITAURBANA

- 040 ALTEREGO
- 034 ISOLAURBANA
- 054 GRANDIFIORIERE
- 046 COBRA

066 BENCHES

- 068 AGATA
- 070 AGORA'
- 078 AIR PORT A
- 082 AIR PORT C
- 074 AIR PORT L
- 072 AIR-PORT COLLECTION L - A - C
- 086 AMBRA
- 232 ANASTASIO
- 234 ANASTASIO ACCESSORIES
- 088 AUSTEN
- 164 BIG HARRIS
- 090 BULL
- 092 CAMPUS
- 096 CANAPE'
- 100 CANN
- 104 CLUB A, B
- 106 COLOR - CORTEN STYLE
- 114 CORTOMADERE

- 124 DIAMANTE ACCESSORIES (I)
- 126 DIAMANTE ACCESSORIES (W)
- 120 DIAMANTE COLLECTION
- 136 DIANE COLLECTION
- 144 DOMUS, DOMUS ISCHIATICA
- 146 FORESTA
- 150 FRECCIA
- 152 GIADA
- 154 HARRIS
- 170 HARRIS ISOLA
- 176 HOBA
- 178 HORN
- 186 I BO A ESSORIES
- 180 I BO OLLE IO
- 194 IDEAS L, T
- 200 ISOMETRICA
- 204 LETTERE
- 208 LIBRE
- 218 LIBRE DOPPIA
- 214 LIBRE EVOLUTION
- 224 LORENZ
- 230 LUCKY
- 236 MAKATITE, REALGAR
- 238 MAMUA
- 240 METEOR COLLECTION
- 323 MIZAR S
- 244 MOOD
- 248 MOONSTONE
- 254 NATURAL PUZZLE

258 NUVOLA
260 PAD
264 PLATINUM COLLECTION
272 PONTE
276 RIVA
278 RIVOLA
284 SARAH
286 SCULPTURE
288 SEDIS - SEDIS TORSION
300 STONE
304 TOSO
306 TREE LINE
314 TRONO, POUF, DIVANO
222 TWIN
328 ULURU COLLECTION
336 UP
342 VALENCIA
344 VICTOR
346 VOLO

354 PICNIC AREA

356 AIR COLLECTION
360 AIR A
362 AIR C
358 AIR L
366 B-B SASS
368 B-BQ
370 C-BQ
372 MERENDA
374 PIC BULL
380 PIC NIC
382 SIL

386 LITTER BINS

388 AERO
394 ANFORA
396 BLADES
398 BLOOM
402 BOTTE
410 BO
418 BRAVO BOOM
416 BRAVO SLIK, HOLE
420 C3
422 CESTIS

424 CESTUM
426 CHANDY
428 CLUB C
430 CONGA
432 CORTE
434 CUP
436 E O I
440 ECOSIDE
442 ECOSPENCER
446 ERMES
450 FLOM
406 GAVITELLO
452 HALLS
454 LANCILLOTTO
456 LYS
458 MARCO BOOM
460 MARTE
462 MASCHERA
444 MILLENNIUM - ERCOLE
464 PACK
468 PARK
470 POD
474 QUARZO
476 QUBA
478 RAINLESS
482 RUBINO
472 SET
484 SI LE O
486 SPENCER COLLECTION

498 SPENCER CP
414 SUPERBRAVO
500 TOM
502 TOPAZIO
504 TULIP
508 YES

512 CIGARETTE BINS

512 BI S A E
514 CICA
516 FU'
518 FUMA
520 GENE
522 MO
524 SCRAMBLER
526 SCUDO
530 SHANGHAI
528 SMOKY

532 BIKE RACKS

534 APOLLO
536 BIKE
538 BI E BO
540 BIPLANO
542 BLAKE
544 CAFE'
546 CHIAVE
548 CICLOS
550 CIRCLE
552 CLOS
554 CRUNA
556 CYCLUS
558 GOMMA
560 GUARDIA
562 HEAD
564 INSIDE
566 LUCCHETTO
568 MIKADO, TJADO
570 MOVE
572 OVAL
574 PITSTOP
576 RESET
578 RUBB
580 SILVER
582 SMERALDO
584 SPRING P

586 SPYRA
590 TYPE

592 BOLLARDS AND BARRIERS

594 CARPI
596 CORALLO
600 CROSS
602 CUBE
606 DELINEA
608 DIFFUSION NEWS
610 DI
612 E LOSIO
614 GALA
616 GENESIS
618 GITTER
620 HARLEM
622 HESPERIA
624 ICS
626 ISTR
595 MAGIC
628 MIZAR D
630 MOKA
632 NEA
634 ONORIUS
636 PALUS
638 PENCIL

640 PIREO
642 QUICK
644 ROUTE
646 SIGARO
648 SPRING D
650 TRANSEO
654 ERSO
652 V-FORM
656 VISION
658 VOILA
660 WORD
664 ZAFFIRO

666 PLANTERS / DRINKING FOUNTAINS / TREE-GRILLES

668 AL A BE A A A
672 ARBORIS
674 ASTER
676 BALZAC
684 BAMBU'
687 AL
688 DAHLIA
692 ECCENTRICA
694 ELLI
698 FLO
704 FLORA - LITTERA - STELO

706 FLORES
708 E E E R
712 HELMUT
714 LAND
716 LOUNGE
718 OBRA R
722 ONICE
720 PERLA C - Q
724 PITOCCA
732 SIZE
728 SPRING F
686 SUNNY
736 TRIANGLE
730 TWISTER

740 DISPLAY STANDS AND INFORMATION POSTS

742 ALTUS - LATUS
744 ANNUNCI
746 ASPEN
748 ATHOS
750 BACH
752 A O I
754 DUPLUS - PARVUS - SINGULA
756 E O

760 ICARO
762 LANZAROTE
763 LEGGIO
764 O IE O
766 PEGASUS
770 SENNA
772 TARGA
774 TED

776 SHELTERS

798 ALHENA
778 ARTS
780 ATENA
782 FOGLIA
784 GPDUE
790 HUT
794 MERAK
800 OMNIBUS
804 PARTNERS
806 PENSILIS 1223 - 1722
814 SELF
818 SINTESI
820 SMART CITY
824 SPACE AUTO
826 SPACE BICI
830 YPSILON

832 PLAYGROUNDS

848 J101
846 J102
838 J201
838 J202
838 J203
840 J204
840 J205
840 J206
842 J207
844 J301
852 J401
858 J402
856 J501
854 J601
854 J701



Metalco's products boast innovative forms dedicated to products' functionality and embody a worldwide renown style. Luxury is made of colors, beauty, distinctiveness, prosperity and makes every citizen and visitor feel like at home. Metalco is focused on are covered by its own photovoltaic system on its plant's roof.

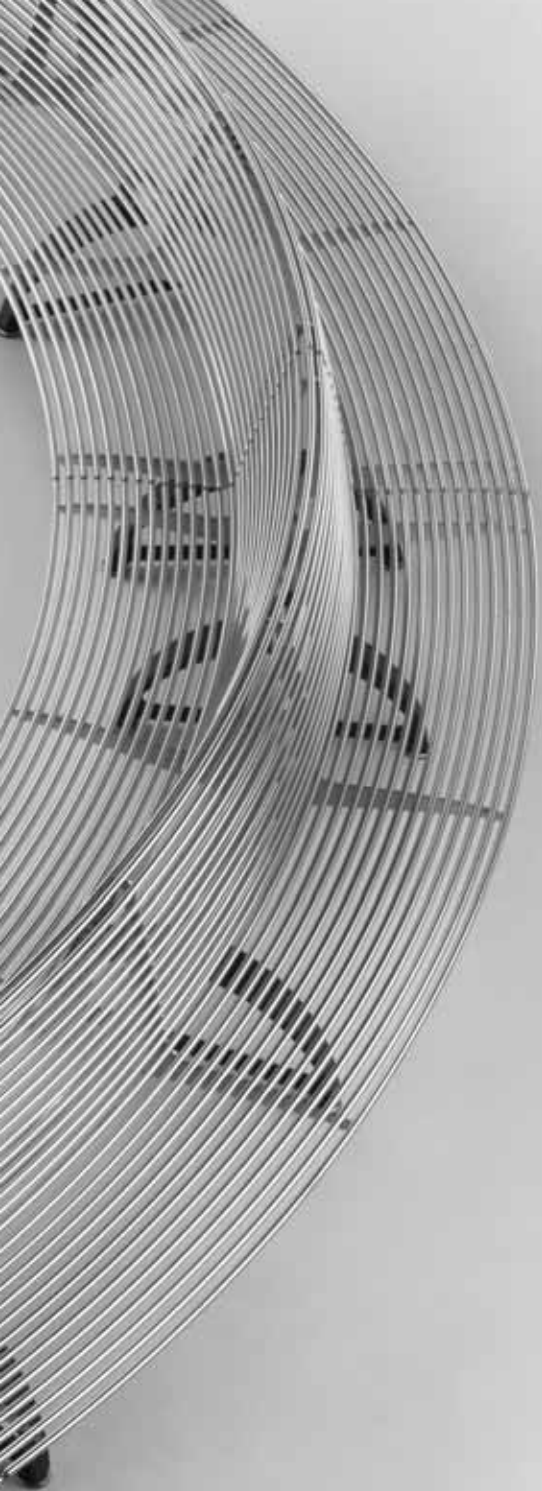

S T I L E

FACTORY and HEADQUARTER

Castelminio di Resana (TV)

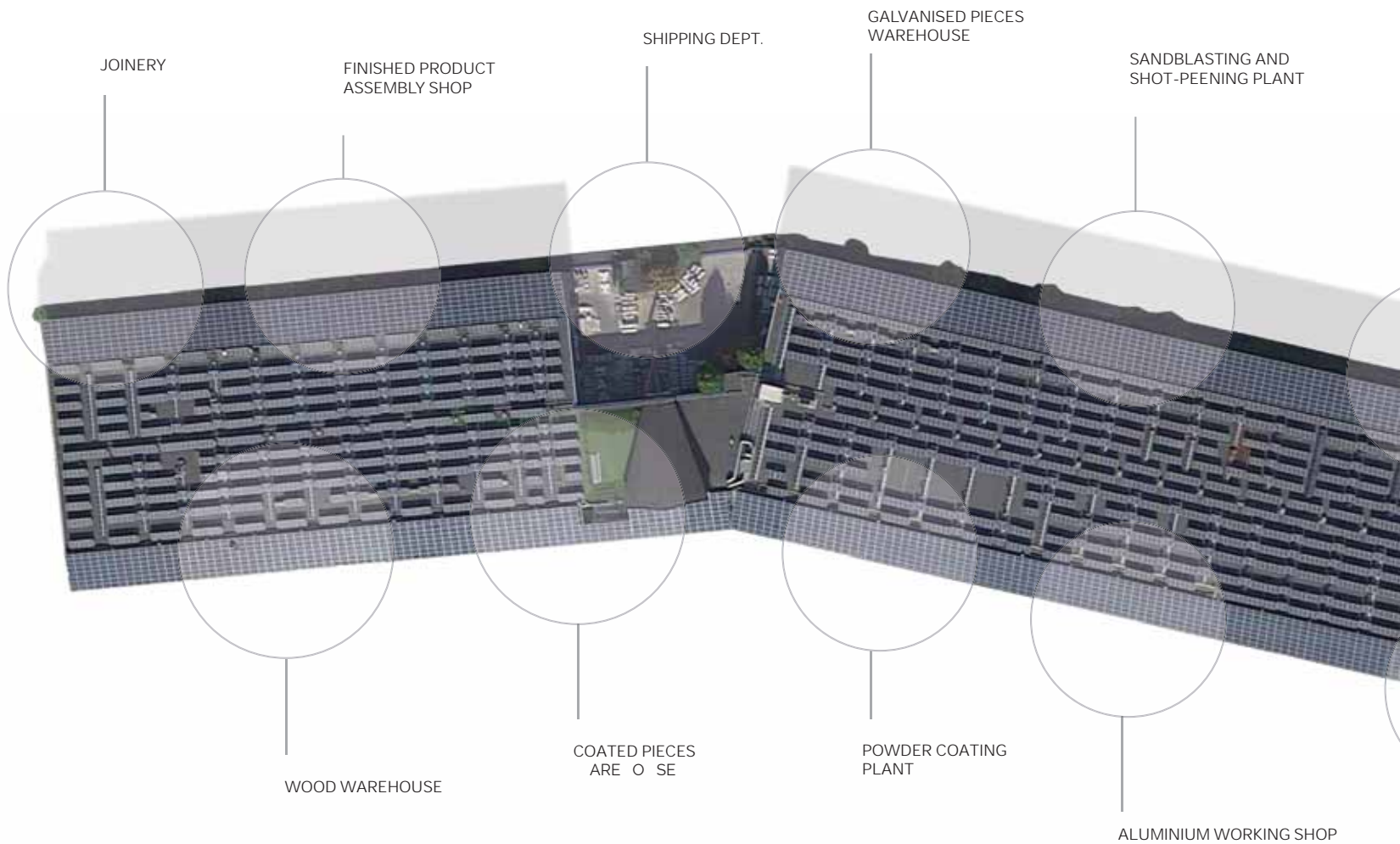

FACTORY

Castelfranco Veneto (TV)

STAINLESS STEEL
WORKING SHOP

ROBOTISED WELDING

MANUAL WELDING

OFFICES

ADMINISTRATION

SALES COMMERCIAL

MARKETING

R&D TECHNICAL

PURCHASING

QUALITY

WORKSITE MANAGEMENT

CNC MACHINE SHOP

LASER CUTTING

TAILOR-MADE
CONSTRUCTIONS



HEADQUARTER

MADE IN ITALY SINCE 1984





FACTORY

MANUFACTURING AREA



WAREHOUSE



CNC MACHINE SHOP

FACTORY

MANUFACTURING AREA



LASER CUTTING



MANUAL WELDING

FACTORY

MANUFACTURING AREA



ALUMINIUM WORKING SHOP



ROBOTISED WELDING



HOT-DIP GALVANISATION (OUTSOURCING)



SANDBLASTING PLANT

FACTORY

MANUFACTURING AREA



POWDER COATING PLANT



POWDER COATING

FACTORY

MANUFACTURING AREA

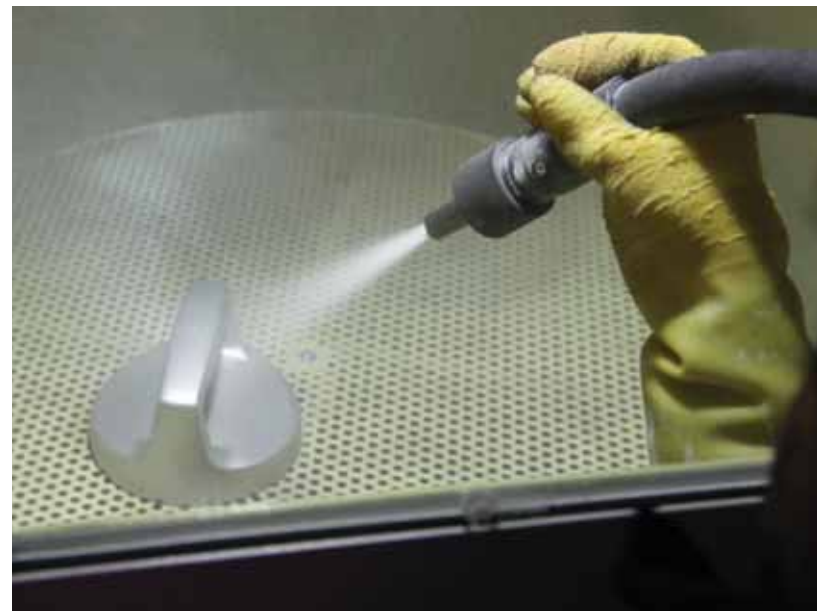

SHOT-PEENING PLANT WITH CERAMIC BALLS



JOINERY

FACTORY

MANUFACTURING AREA



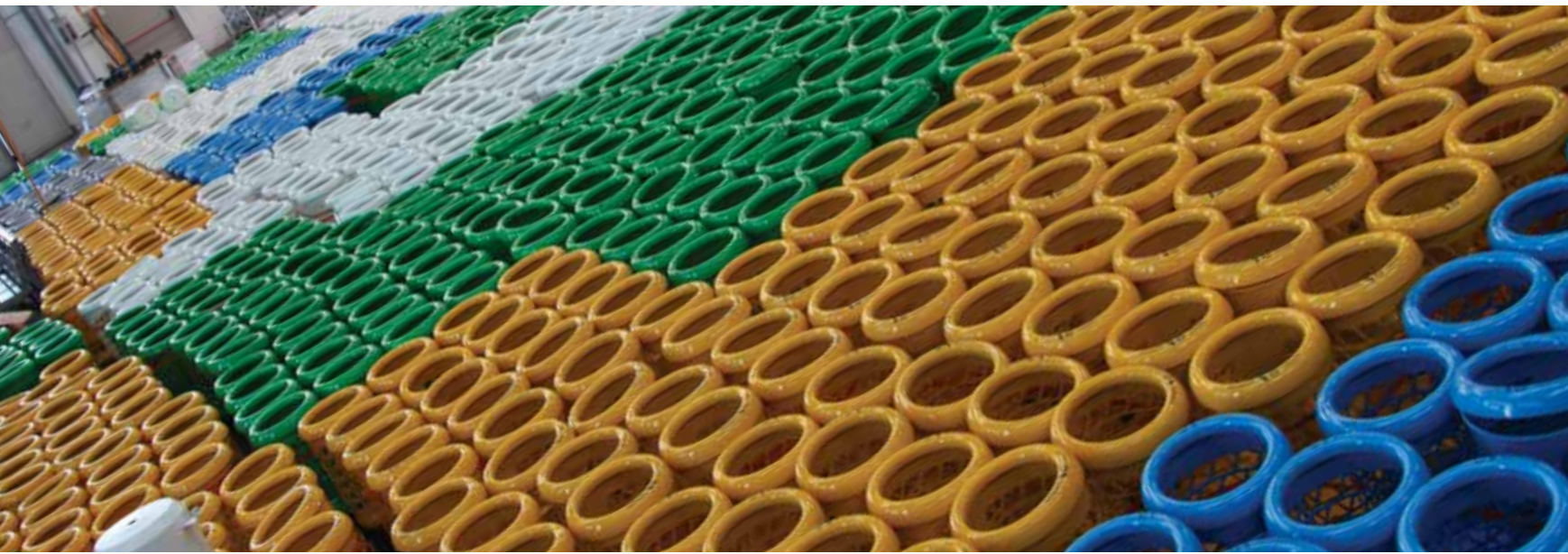

FACTORY

MANUFACTURING AREA



MATERIAL READY TO BE SHIPPED



POWDER COATED STEEL

ALUMINUM

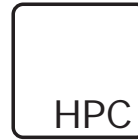

HIGH PERFORMANCE CONCRETE



STAINLESS STEEL



ULTRA HIGH PERFORMANCE CONCRETE



CORTEN STEEL



RECONSTITUTED STONES



WOOD



HIGH DENSITY POLYETHYLENE



WOOD PLASTIC COMPOSITE



POLYÉTHYLÈNE

VITAURBANA (urban life): TAKE A SEAT ON THE LANDSCAPE

Life is made of encounters, exchanges, open-air activities, urban landscape.

A urban space becomes alive with people. Metalco by VITAURBANA(urban life) creates new ways to live the city, conceiving a collection which embodies the historic concept of "square".

This collection matches a captivating design (Metalco's style in street furniture) with the most sophisticated technologies SMART.

Metalco's goal is to provide an alphabet by which everyone may create its own urban vocabulary and may invent new places, new spaces to live the city, big planters carrying public seats which join the space, because "every place is home"



VITAURBANA

ISOLAURBANA - ALTEREGO - COBRA - GRANDIFIORIERE





ISOLAURBANA

DESIGN MASSIMO TASCA + RAFFAELE LAZZARI



D



DTS



DTS+A



W2





W



WT



FA



FB



CF

ISOLAURBANA

DESIGN MASSIMO TASCA + RAFFAELE LAZZARI



MATERIALS:

LARCH WOOD OR EXOTIC WOOD OR HIGH PERFORMANCE CONCRETE +
POWDER COATED ALUMINIUM + POWDER COATED STEEL

FINISHES:

p. 977

FIXINGS:

PRE DRILLED FOR ANCHORS

DRAWINGS: p. 900





ISOLAURBANA

DESIGN MASSIMO TASCA + RAFFAELE LAZZARI







ALTEREGO

DESIGN MASSIMO TASCA + MATTIA LI POMI



1D



4V

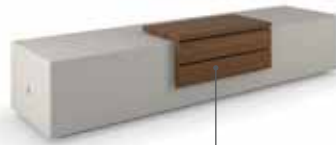

SP

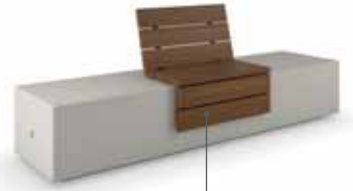

SS



OM



PP



4VC



FG

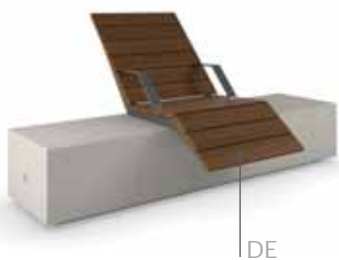

DE



TA



FP



FS

ALTEREGO

DESIGN MASSIMO TASCA + MATTIA LI PONI



MATERIALS:

HIGH PERFORMANCE CONCRETE OR POWDER COATED STEEL
OR CORTEN STEEL + LARCH WOOD OR EXOTIC WOOD

FINISHES:

SMOOTH SEAT AND SIDES VELLUTO

FIXINGS:

FREE STANDING OR PREDRILLED FOR ANCHORS

DRAWINGS: p. 901 - 902



USB



ALTEREGO

DESIGN MASSIMO TASCA + MATTIA LI POMI







COBRA

DESIGN MASSIMO TASCA



CA



CO



CV





CR

COBRA

DESIGN MASSIMO TASCA



MATERIALS:

LARCH WOOD OR EXOTIC WOOD + POWDER COATED STEEL OR CORTEN

FIXINGS:

PREDRILLED FOR ANCHORS OR BELOW GROUND

DRAWINGS: p. 903



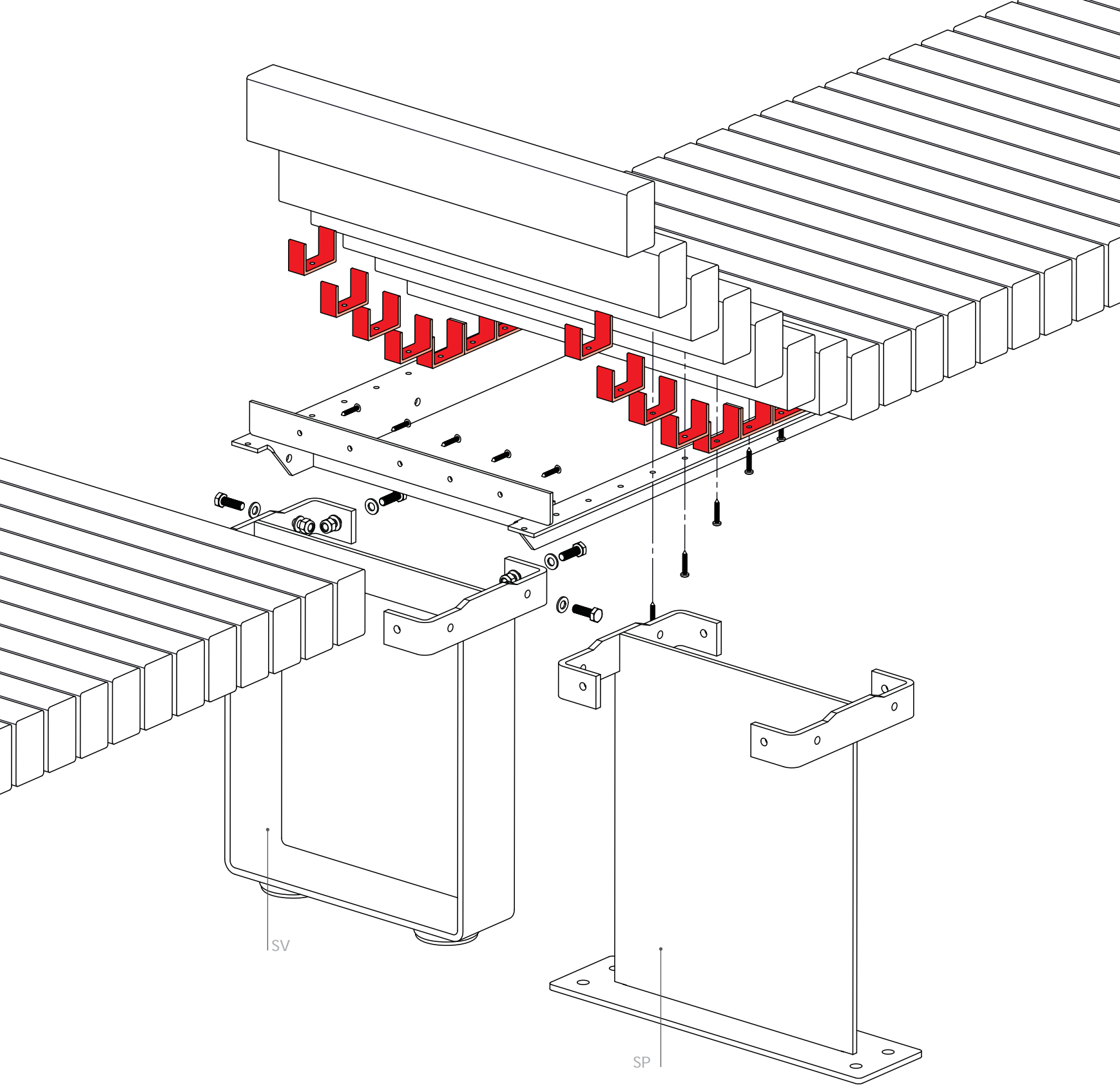



COBRA

The Metalco patent with the technopolymer “U” element has three advantages:

- 1 – the wood never rests directly on the steel structure, but is at a distance, therefore avoiding water stagnation
- 2 – makes the wood stay in a correct vertical position
- 3 – acts as an elastic coupling, ensuring grip despite the loosening of the screws over time, due to the natural movement of the wood.





COBRA

DESIGN MASSIMO TASCA







GRANDIFIORIERE

DESIGN MASSIMO TASCA



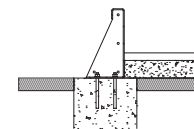
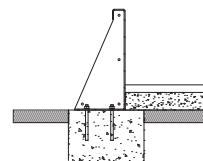
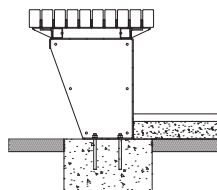
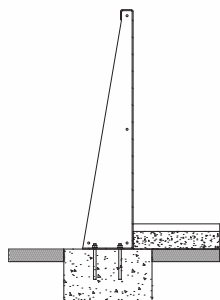

GRANDIFIORIERE

DESIGN MASSIMO TASCA

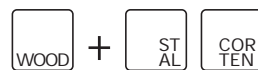

MATERIALS:

LARCH WOOD OR EXOTIC WOOD + POWDER COATED STEEL OR CORTEN

FIXINGS:

PREDRILLED FOR ANCHORS OR BELOW GROUND

DRAWINGS: p. 904



GRANDIFIORIERE

DESIGN MASSIMO TASCA

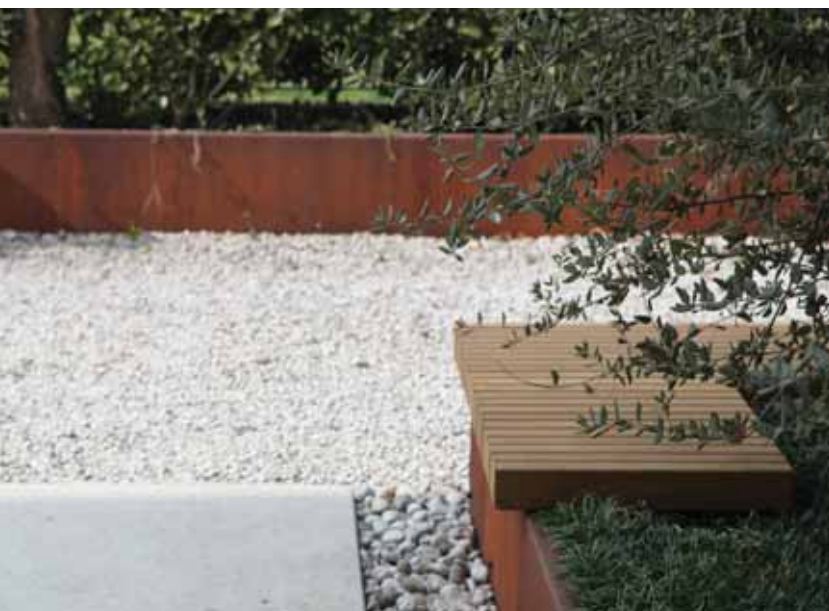















SEA S &

A close-up photograph of a dark, textured, curved object, likely a piece of furniture like a bench or chair. The object is shown in profile, with a smooth, rounded top edge and a vertical section below. The background is a light, neutral color. A dark horizontal band is overlaid across the middle of the image, containing the word "BENCHES" in white capital letters.

BENCHES



AGATA SETTORE



AGATA



AGATA

DESIGN ALFREDO TASCA

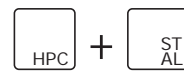

MATERIALS:

HIGH PERFORMANCE CONCRETE + POWDER COATED STEEL

FINISHES:

p. 977

FIXINGS:

PRE DRILLED FOR ANCHORS

DRAWINGS: p. 919







AGORÀ

DESIGN ALESSANDRO LENARDA



MATERIALS:

POWDER COATED STEEL OR EXOTIC WOOD + POWDER COATED

FIXINGS:

PRE DRILLED FOR ANCHORS

DRAWINGS: p. 929



L



LXS



LDX



A



ASX





ADX

C

CS

CW

MODULAR BENCHES
AIR-PORT COLLECTION L - A - C

DESIGN ALFREDO TASCA
MASSIMO TASCA - RAFFAELE LAZZARI







L



LXS



LDX

AIR-PORT L

DESIGN ALFREDO TASCA
MASSIMO TASCA - RAFFAELE LAZZARI



MATERIALS:

LARCH WOOD OR EXOTIC WOOD + POWDER COATED ALUMINUM

FIXINGS:

FREESTANDING WITH PEDESTALS OR INSTALLATION WITH THREADED

DRAWINGS: p. 908





AIR-PORT L

DESIGN ALFREDO TASCA
MASSIMO TASCA - RAFFAELE LAZZARI







A



ASX



ADX

AIR-PORT A

DESIGN ALFREDO TASCA
MASSIMO TASCA - RAFFAELE LAZZARI



MATERIALS:

POWDER COATED STEEL + POWDER COATED ALUMINUM

FIXINGS:

FREESTANDING WITH PEDESTALS OR INSTALLATION WITH THREADED BARS

DRAWINGS: p. 908











C



CS



CW

AIR-PORT C

DESIGN ALFREDO TASCA
MASSIMO TASCA - RAFFAELE LAZZARI



MATERIALS:

ULTRA HIGH PERFORMANCE CONCRETE + POWDER COATED ALUMINUM

FINISHES:

ALFA

FIXINGS:

FREESTANDING WITH PEDESTALS OR INSTALLATION WITH THREADED BARS

DRAWINGS: p. 908



AIR-PORT C

DESIGN ALFREDO TASCA
MASSIMO TASCA - RAFFAELE LAZZARI







AMBRA

DESIGN ALENA MOCOVIÄ



MATERIALS:

RECONSTITUTED STONES

FINISHES:

SMOOTH SEAT AND SANDBLASTED SIDES

FIXINGS:

BELOW GROUND INSTALLATION WITH THREADED BARS

DRAWINGS: p. 918





AUSTEN

METALCO DESIGN



MATERIALS:

ULTRA HIGH PERFORMANCE CONCRETE + LARCH WOOD
OR EXOTIC WOOD

FINISHES:

ALFA

FIXINGS:

FREESTANDING WITH PEDESTALS OR INSTALLATION WITH THREADED

DRAWINGS: p. 914





BULL

DESIGN ALFREDO TASCA



MATERIALS:

LARCH WOOD OR EXOTIC WOOD + POWDER COATED STEEL OR CORTEN
STEEL OR STAINLESS STEEL

FIXINGS:

PRE DRILLED FOR ANCHORS

DRAWINGS: p. 921

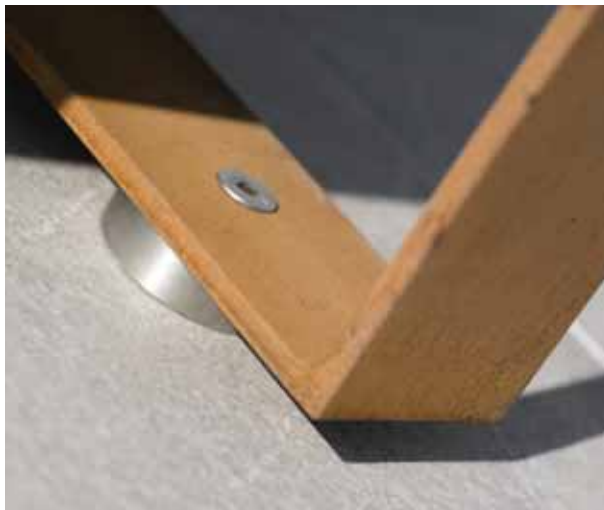





CAMPUS

METALCO DESIGN

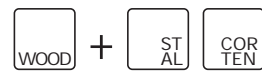

MATERIALS:

LARCH WOOD OR EXOTIC WOOD + POWDER COATED STEEL OR CORTEN

FIXINGS:

PRE DRILLED FOR ANCHORS

DRAWINGS: p. 922



CAMPUS

METALCO DESIGN





OTTICA DI NATALE
+13

OTTICA DI NATALE

40
50

BEN

VENUTA



CANAPÈ

METALCO DESIGN



MATERIALS:

WOOD + POWDER COATED STEEL OR CORTEN STEEL

FIXINGS:

PRE DRILLED FOR ANCHORS

DRAWINGS: p. 921



CANAPÈ

METALCO DESIGN







CANN

DESIGN MASSIMO TASCA

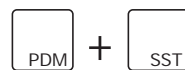

MATERIALS:

RECONSTITUTED STONES + STAINLESS STEEL

FINISHES:

SMOOTH SEAT AND MIXED SANDBLASTED - VELLUTO SIDES

FIXINGS:

INSTALLATION WITH THREADED BARS

DRAWINGS: p. 914









CLUB A, B

DESIGN ERIC MANFRINO



MATERIALS:

POWDER COATED STEEL OR CORTEN STEEL + TEAK WOOD

FIXINGS:

PRE DRILLED FOR ANCHORS

DRAWINGS: p. 920







COLOR - CORTEN STYLE

AUREL DESIGN URBAIN



COLOR - CORTEN STYLE DEA - DIVA - ELA - LUA - STELLA

AUREL DESIGN URBAIN



MATERIALS:

COATED STEEL OR CORTEN STEEL

FIXINGS:

PRE DRILLED FOR ANCHORS

DRAWINGS: p. 922





COLOR - CORTEN STYLE
DEA - DIVA - ELA - LUA - STELLA

AUREL DESIGN URBAIN









CMP



CMS



CM3P



CM3S





CMC



CORTOMADERE

DESIGN AGENCE LAVERNE PAYSAGISTES



MATERIALS:

POWDER COATED STEEL OR CORTEN STEEL

FIXINGS:

PRE DRILLED FOR ANCHORS

DRAWINGS: p. 923



CORTOMADERE

DESIGN AGENCE LAVERNE PAYSAGISTES



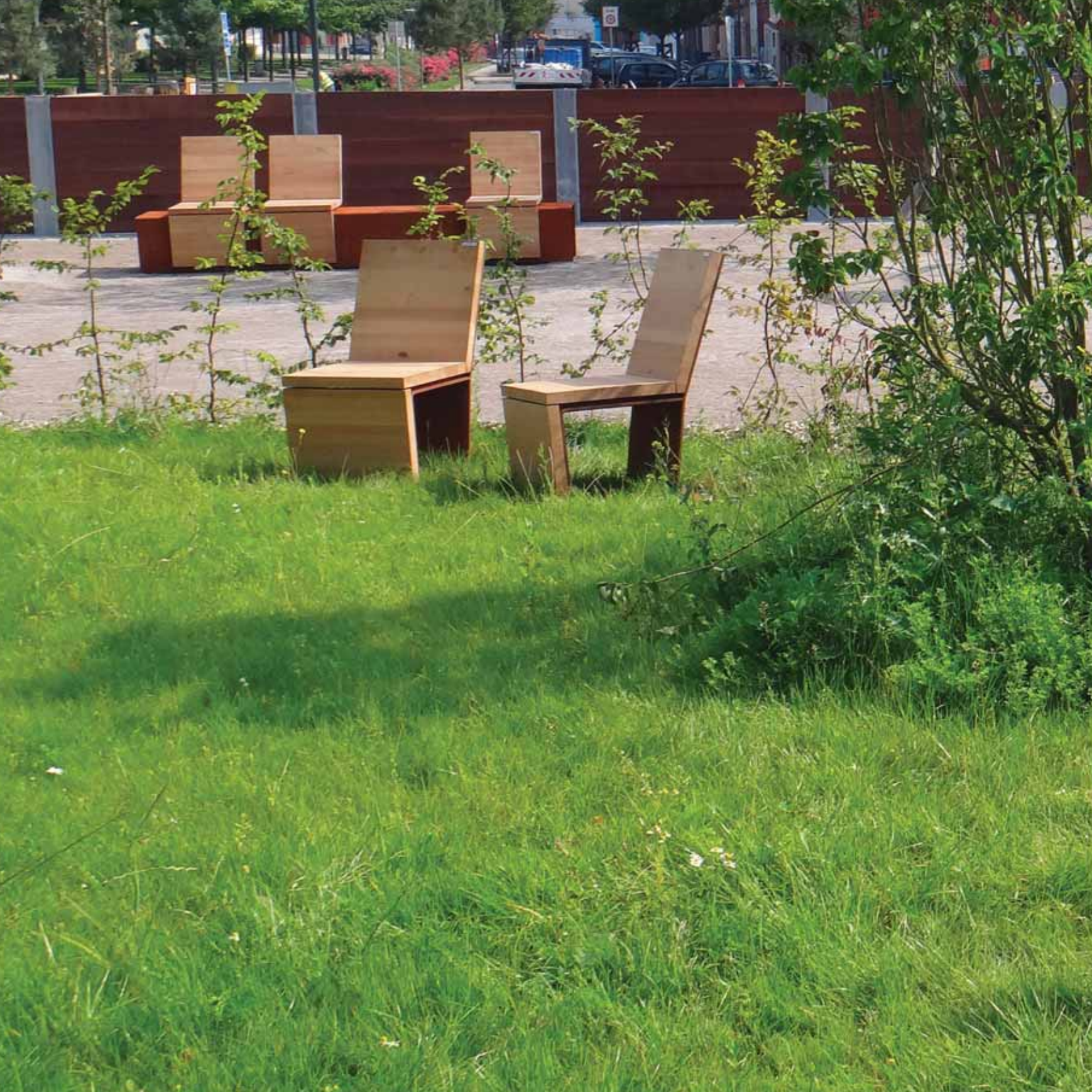





DIAMANTE COLLECTION



PONT RAYMOND BARRE



P



S15°



S45°





F



SUV

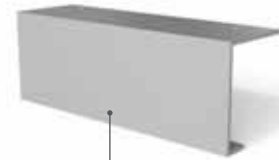

SUP



DIAMANTE COLLECTION

DESIGN SLAVIERO + LENARDA + LAZZARI

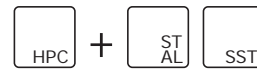

MATERIALS:

HIGH PERFORMANCE CONCRETE + POWDER COATED STEEL OR STAINLESS STEEL

FINISHES:

p. 976 -977

FIXINGS:

PRE DRILLED FOR ANCHORS

DRAWINGS: p. 916

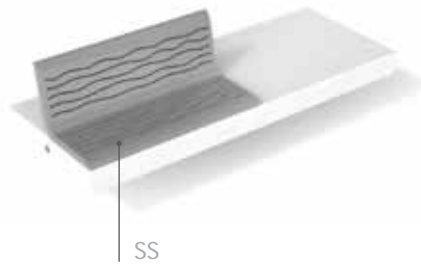
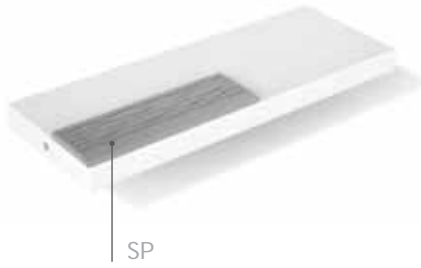

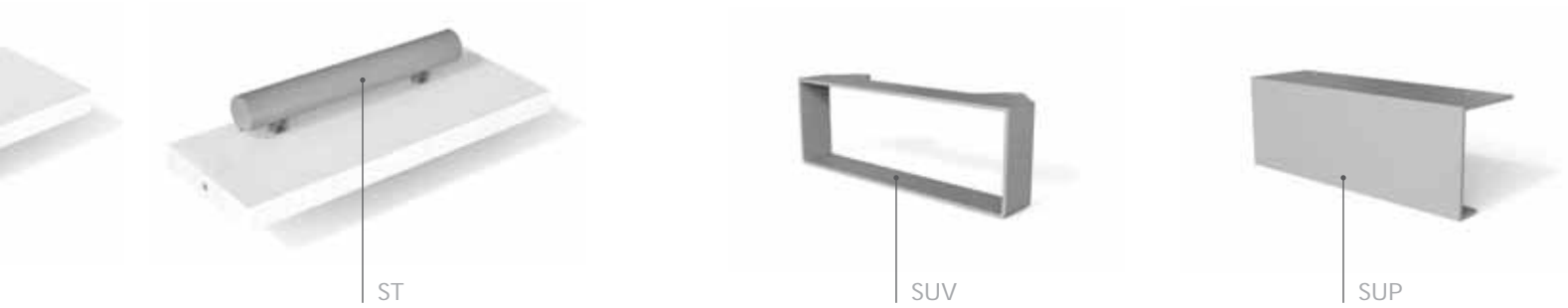

DIAMANTE ACCESSORIES (I)

DESIGN SLAVIERO + LENARDA + LAZZARI



MATERIALS:

POWDER COATED STEEL

FIXINGS:

PRE DRILLED FOR ANCHORS

DRAWINGS: p. 917

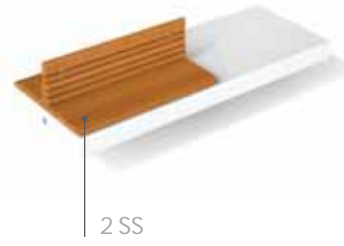
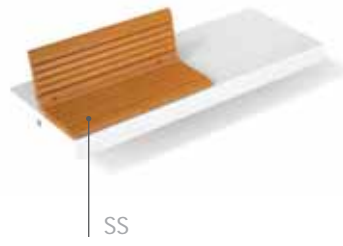
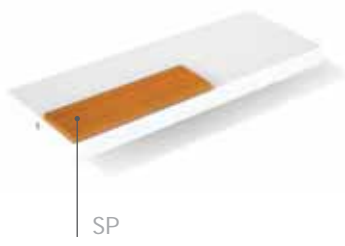



DIAMANTE ACCESSORIES (W)

DESIGN SLAVIERO + LENARDA + LAZZARI



MATERIALS:

EXOTIC WOOD

FIXINGS:

PRE DRILLED FOR ANCHORS

DRAWINGS: p. 916 - 917







DIAMANTE COLLECTION

DESIGN SLAVIERO + LENARDA + LAZZARI









SHELTER:
VINCENT GUILLERMIN DESIGN

DIAMANTE COLLECTION

DESIGN SLAVIERO + LENARDA + LAZZARI











DIANE COLLECTION

DESIGN STUDIO WILMOTTE



DIANE | BANC BASSE

DIANE | VAGUE

DIANE | TABLE HAUTE



DIANE COLLECTION

DESIGN STUDIO WILMOTTE

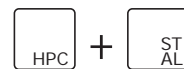

MATERIALS:

HIGH PERFORMANCE CONCRETE + POWDER COATED STEEL

FINISHES:

SMOOTH SEAT AND SIDES

FIXINGS:

PRE DRILLED FOR ANCHORS

DRAWINGS: p. 915





DIANE COLLECTION

DESIGN STUDIO WILMOTTE





DIANE COLLECTION

DESIGN STUDIO WILMOTTE





DOMUS, DOMUS ISCHIATICA

DESIGN ALFREDO TASCA



MATERIALS:

POWDER COATED STEEL OR STAINLESS STEEL + POWDER COATED

FIXINGS:

FREE STANDING WITH PEDESTALS OR PREDRILLED FOR ANCHORS
OR INSTALLATION WITH THREADED BARS

DRAWINGS: p. 924





FORESTA

DESIGN MASSIMO TASCA



MATERIALS:

LARCH WOOD + POWDER COATED STEEL

FIXINGS:

PREDRILLED FOR ANCHORS OR BELOW GROUND

DRAWINGS: p. 909





FORESTA

DESIGN MASSIMO TASCA





FRECCIA

DESIGN ALFREDO TASCA + RAFFAELE LAZZARI



MATERIALS:

POWDER COATED STEEL + STAINLESS STEEL

FIXINGS:

BELOW GROUND INSTALLATION WITH THREADED BARS

DRAWINGS: p. 924







GIADA

DESIGN STAUBACH & KUCKERTZ

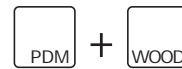

MATERIALS:

RECONSTITUTED STONES + LARCH WOOD OR EXOTIC WOOD

FINISHES:

SMOOTH SEAT AND SANDBLASTED SIDES

FIXINGS:

FREE STANDING

DRAWINGS: p. 913



A man with a beard and short hair, wearing a grey pinstriped suit, a white shirt, and a dark tie, is sitting on a wooden bench outdoors. He is looking down at a tablet computer he is holding in his hands. He is also wearing white earbuds. The background shows a brick wall and some greenery under a clear sky.

HARRIS COLLECTION



VERSION (A)

VERSION (B)



HARRIS COLLECTION

DESIGN SJIT



MATERIALS:

LARCH WOOD OR EXOTIC WOOD

The whole collection (HARRIS, BIG HARRIS, HARRIS ISOLA) can be chosen: with wooden boards with staggered joints (version A) or full length wooden boards (version B)



H 200



HS 200



H300



MODULAR BENCHES



HSC 300



H2S 300



VERSION (A)



VERSION (B)

HARRIS

DESIGN SJIT



MATERIALS:

LARCH WOOD OR EXOTIC WOOD OR WPC + POWDER COATED
STEEL OR CORTEN STEEL

FIXINGS:

PRE DRILLED FOR ANCHORS

DRAWINGS: p. 925









HARRIS

DESIGN SJIT





BH 1076



BH 2076



BH 3076





BH 4076



VERSION (A)



VERSION (B)

BIG HARRIS

DESIGN SJIT



MATERIALS:

LARCH WOOD OR EXOTIC WOOD OR WPC + POWDER COATED
STEEL OR CORTEN STEEL

FIXINGS:

PRE DRILLED FOR ANCHORS

DRAWINGS: p. 925





BIG HARRIS

DESIGN SJIT









HI 1576



HIA 1550



HI 2076





TAILORED



VERSION (A)



VERSION (B)

HARRIS ISOLA

DESIGN SJIT



MATERIALS:

LARCH WOOD OR EXOTIC WOOD OR WPC + POWDER COATED
STEEL OR CORTEN STEEL

FIXINGS:

PRE DRILLED FOR ANCHORS

DRAWINGS: p. 925





HARRIS ISOLA

DESIGN SJIT









Deloitte

HOBA B

HOBA A



HOBA

DESIGN PIO & TITO TOSO



MATERIALS:

HIGH PERFORMANCE CONCRETE

FINISHES:

VELLUTO

FIXINGS:

FREESTANDING WITH PEDESTALS OR INSTALLATION WITH THREADED

DRAWINGS: p. 915







HORN

METALCO DESIGN



MATERIALS:

LARCH WOOD OR EXOTIC WOOD + POWDER COATED ALUMINIUM

FIXINGS:

FREE STANDING OR INSTALLATION WITH THREADED BARS

DRAWINGS: p. 923



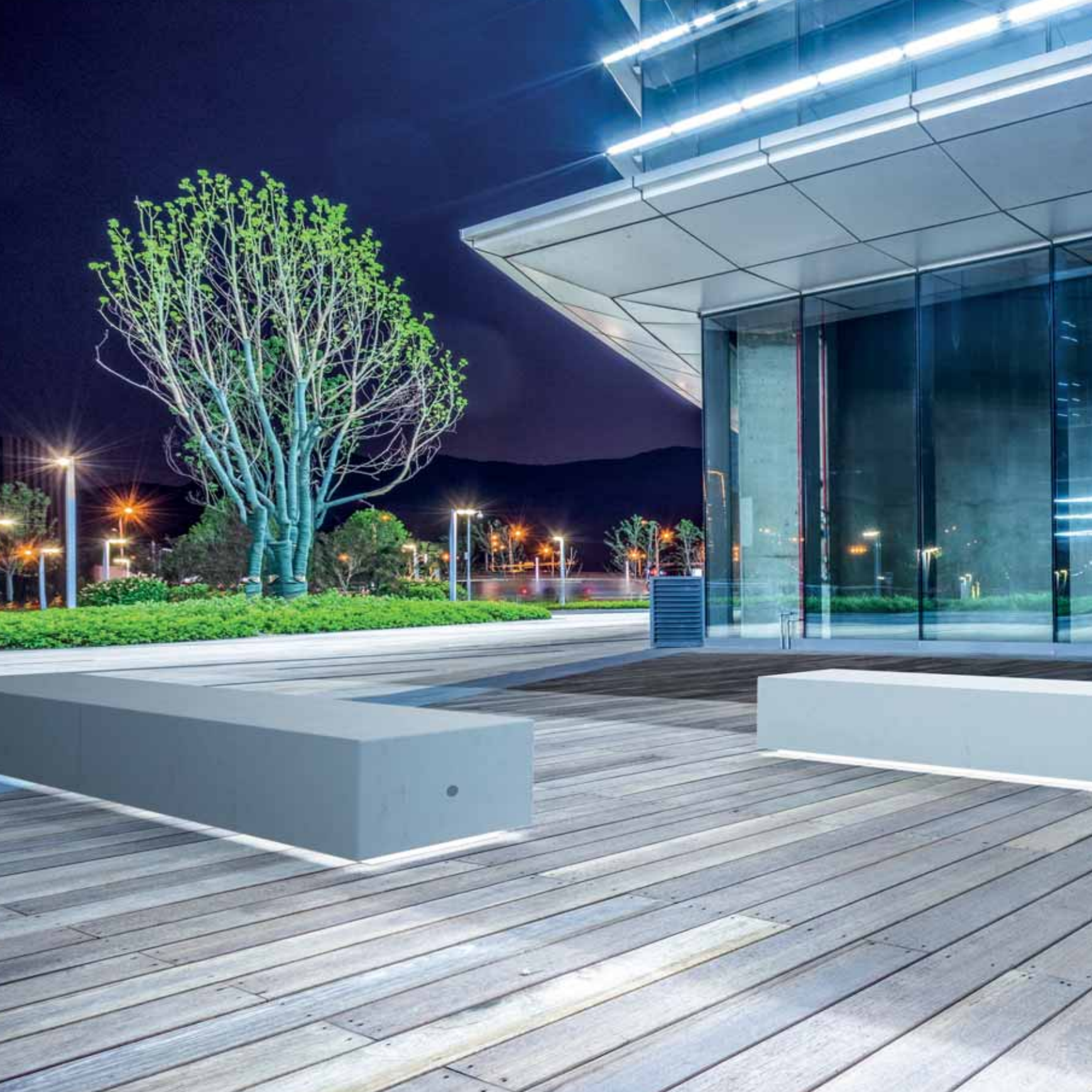



I-BOX COLLECTION

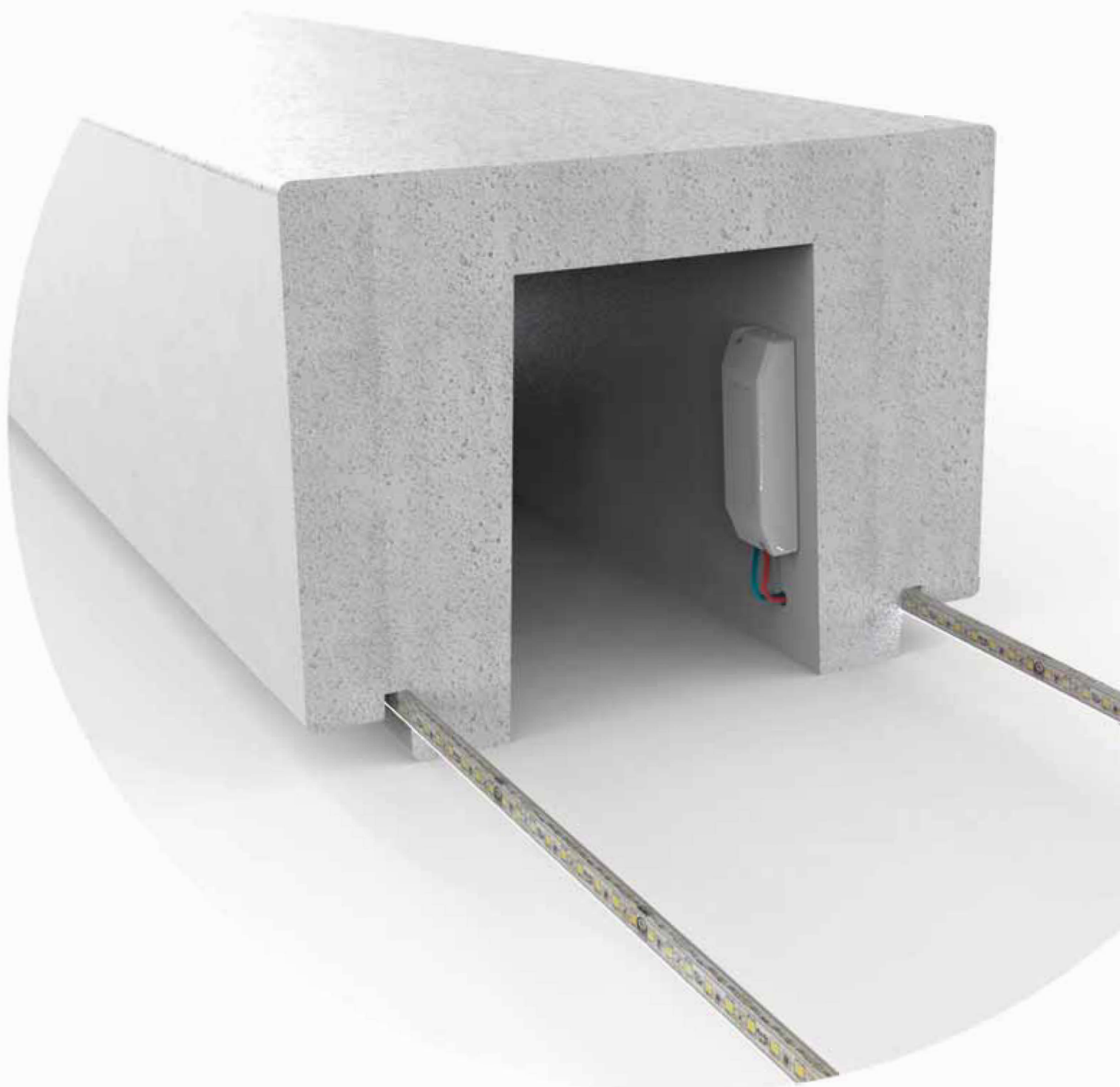

... not just geometrical seats.

- 1 - We have made (upon request and with additional cost) a housing to insert LED strips with relative power supply on the entire I-BOX collection.
- 2 - All elements of the collection are lighter, significantly decreasing transport and installation costs.
- 3 - A series of applicable accessories (upon request and with additional cost) complete the collection, as powder coated steel single and double backrests, powder coated steel armrests with or without sockets to recharge telephones, tablets and computers.

I-BOX COLLECTION



1D



4V



1S/2S





R1



R2



I-BOX COLLECTION

DESIGN PIO & TITO TOSO



MATERIALS:

HIGH PERFORMANCE CONCRETE

FINISHES:

SMOOTH SEAT AND SIDES VELLUTO

FIXINGS:

FREE STANDING

DRAWINGS: p. 913

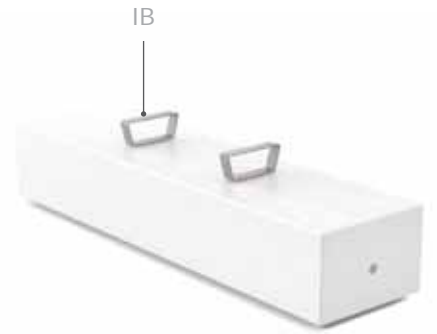
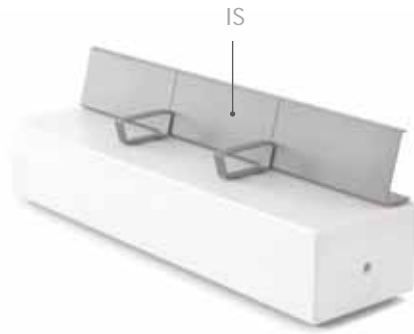

ISR1



ISR2



I-BOX ACCESSORIES

DESIGN PIO & TITO TOSO



MATERIALS:

POWDER COATED STEEL

DRAWINGS: p. 913





I-BOX COLLECTION

DESIGN PIO & TITO TOSO









I-BOX COLLECTION

DESIGN PIO & TITO TOSO







IDEAS L, T

DESIGN ALFREDO TASCA



MATERIALS:

POWDER COATED STEEL OR CORTEN STEEL + LARCH WOOD OR EXOTIC

FIXINGS:

PRE DRILLED FOR ANCHORS

DRAWINGS: p. 926



IDEAS L, T

DESIGN ALFREDO TASCA











ISOMETRICA

DESIGN GIULIO IACHETTI



MATERIALS:

POWDER COATED ALUMINUM

FIXINGS:

FREE STANDING OR INSTALLATION WITH THREADED BARS

DRAWINGS: p. 922





ISOMETRICA

DESIGN GIULIO IACHETTI





TIME

LETTERE

DESIGN STAUBACH & KUCKERTZ



MATERIALS:

POWDER COATED STEEL

PRE DRILLED FOR ANCHORS

DRAWINGS: p. 910





LETTERE

DESIGN STAUBACH & KUCKERTZ







LIBRE COLLECTION



LP 200/300



L 200/300



LP SI



LP SE



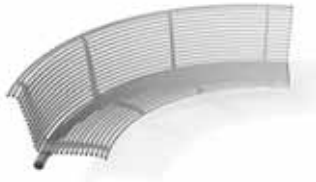

LSI



LSE

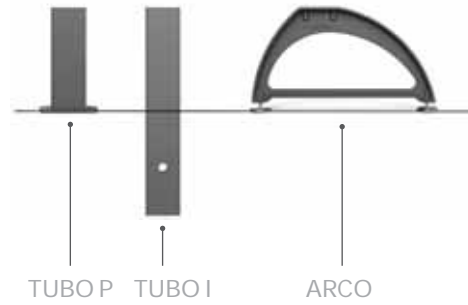

TUBOP

TUBOI

ARCO

LIBRE

DESIGN ALFREDO TASCA



MATERIALS:

POWDER COATED STEEL OR STAINLESS STEEL + POWDER COATED ALUMINUM OR POWDER COATED STEEL

FIXINGS:

FREE STANDING WITH PEDESTALS OR PREDRILLED FOR ANCHORS OR BELOW GROUND INSTALLATION

DRAWINGS: p. 926 - 927



NO STANDARD CONFIGURATION



LIBRE

DESIGN ALFREDO TASCA





LEP 2000



LE 2000



HDX 2700



HSX 2700





TDX 2700



TSX 2700



TUBO P

TUBO I

ARCO D

LIBRE EVOLUTION

DESIGN ALFREDO TASCA



MATERIALS:

POWDER COATED STEEL OR STAINLESS STEEL + POWDER COATED ALUMINUM OR POWDER COATED STEEL

FIXINGS:

FREE STANDING WITH PEDESTALS OR PREDRILLED FOR ANCHORS OR BELOW GROUND INSTALLATION

DRAWINGS: p. 926 - 927











LIBRE DOPPIA



DP



D



DPS 22.5



DS 22.5





DPS 90



DS 90

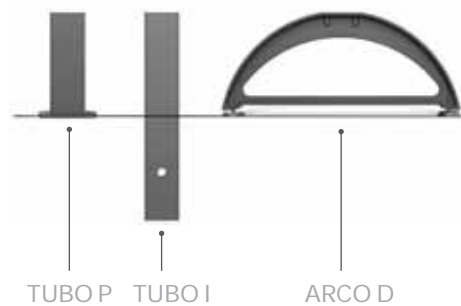

TUBO P

TUBO I

ARCO D

LIBRE DOPPIA

DESIGN ALFREDO TASCA



MATERIALS:

POWDER COATED STEEL OR STAINLESS STEEL + POWDER COATED ALUMINUM OR POWDER COATED STEEL

FIXINGS:

FREE STANDING WITH PEDESTALS OR PREDRILLED FOR ANCHORS OR BELOW GROUND INSTALLATION

DRAWINGS: p. 928









L1000PP



L1000PA



L2200PP



L2200PA





L1000SP



L1000SA



L2200SP



L2200SA



LS



LORENZ

DESIGN PIO & TITO TOSO + MASSIMO TASCA +
MATTIA LI POMI

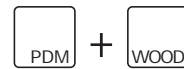

MATERIALS:

RECONSTITUTED STONES + EXOTIC WOOD

FINISHES:

p. 975

FIXINGS:

FREE STANDING

DRAWINGS: p. 911



LORENZ

DESIGN PIO & TITO TOSO + MASSIMO TASCA +
MATTIA LI POMI





LORENZ

DESIGN PIO & TITO TOSO + MASSIMO TASCA + MATTIA LI POMI





MUSEO CIVICO



AWARDED AT THE 6TH EDITION OF THE SALON
PROFESSIONNEL URBEST

LUCKY

DESIGN ALFREDO TASCA



MATERIALS:

POWDER COATED STEEL OR CORTEN STEEL OR STAINLESS STEEL + LARCH
WOOD OR EXOTIC WOOD

FIXINGS:

PRE DRILLED FOR ANCHORS

DRAWINGS: p. 906







ANASTASIO

DESIGN ALONZI + DE NAPOLI + VEDUNO + TRONCHIN



MATERIALS:

RECONSTITUTED STONES

FINISHES:

SMOOTH SEAT AND SANDBLASTED SIDES

FIXINGS:

FREE STANDING

DRAWINGS: p. 919



ANASTASIO ACCESSORIES

DESIGN ALONZI + DE NAPOLI + VEDUNO + TRONCHIN

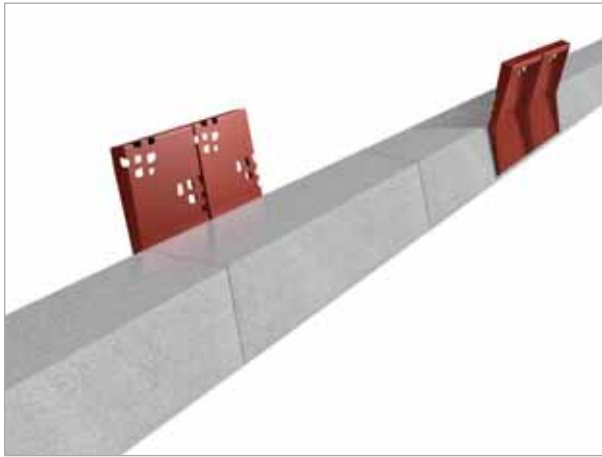

MATERIALS:

POWDER COATED STEEL OR EXOTIC WOOD

DRAWINGS: p. 919

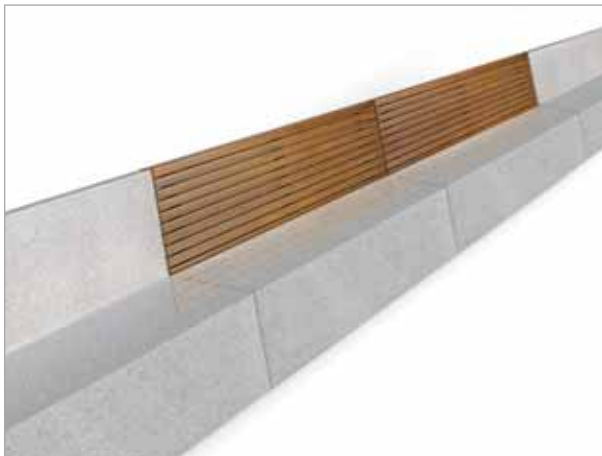





MODULAR BENCHES

MAKATITE



REALGAR



MAKATITE, REALGAR

DESIGN ALONZI + DE NAPOLI + VEDUNO + TRONCHIN



MATERIALS:

RECONSTITUTED STONES

FINISHES:

p. 974

FIXINGS:

FREE STANDING

DRAWINGS: p. 919





H 800 SB



H 550 SB



SB

MAMUÀ

DESIGN CZSTUDIO

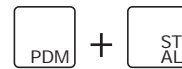

MATERIALS:

RECONSTITUTED STONES + POWDER COATED STEEL

FINISHES:

POLISHED SEAT AND SANDBLASTED SIDES

FIXINGS:

FREE STANDING

DRAWINGS: p. 914







METEOR COLLECTION

DESIGN SAMULI NAAMANKA





METEOR P



METEOR S



METEOR Y

METEOR COLLECTION

DESIGN SAMULI NAAMANKA



MATERIALS:

HIGH PERFORMANCE CONCRETE OR ULTRA HIGH PERFORMANCE CONCRETE

FINISHES:

VELLUTO (HPC)
ALFA (UHPC)

FIXINGS:

FREESTANDING WITH PEDESTALS OR INSTALLATION WITH THREADED BARS

DRAWINGS: p. 915







MSD



MS



MP

MOOD

DESIGN STAUBACH & KUCKERTZ



MATERIALS:

POWDER COATED STEEL

FIXINGS:

PRE DRILLED FOR ANCHORS

DRAWINGS: p. 921



MOOD

DESIGN STAUBACH & KUCKERTZ





A photograph of a park with many trees and people sitting on a bench. The scene is bright and sunny, with a clear sky. The trees are lush green and have a dense canopy. In the foreground, a man in a light blue shirt is sitting on a white, curved bench. To the right, a tall, grey, cylindrical pole stands in the center. In the background, there are several cars parked, including a blue van and a white car. A few other people are walking or standing near the cars. The overall atmosphere is peaceful and green.

MOONSTONE

PAMIO DESIGN

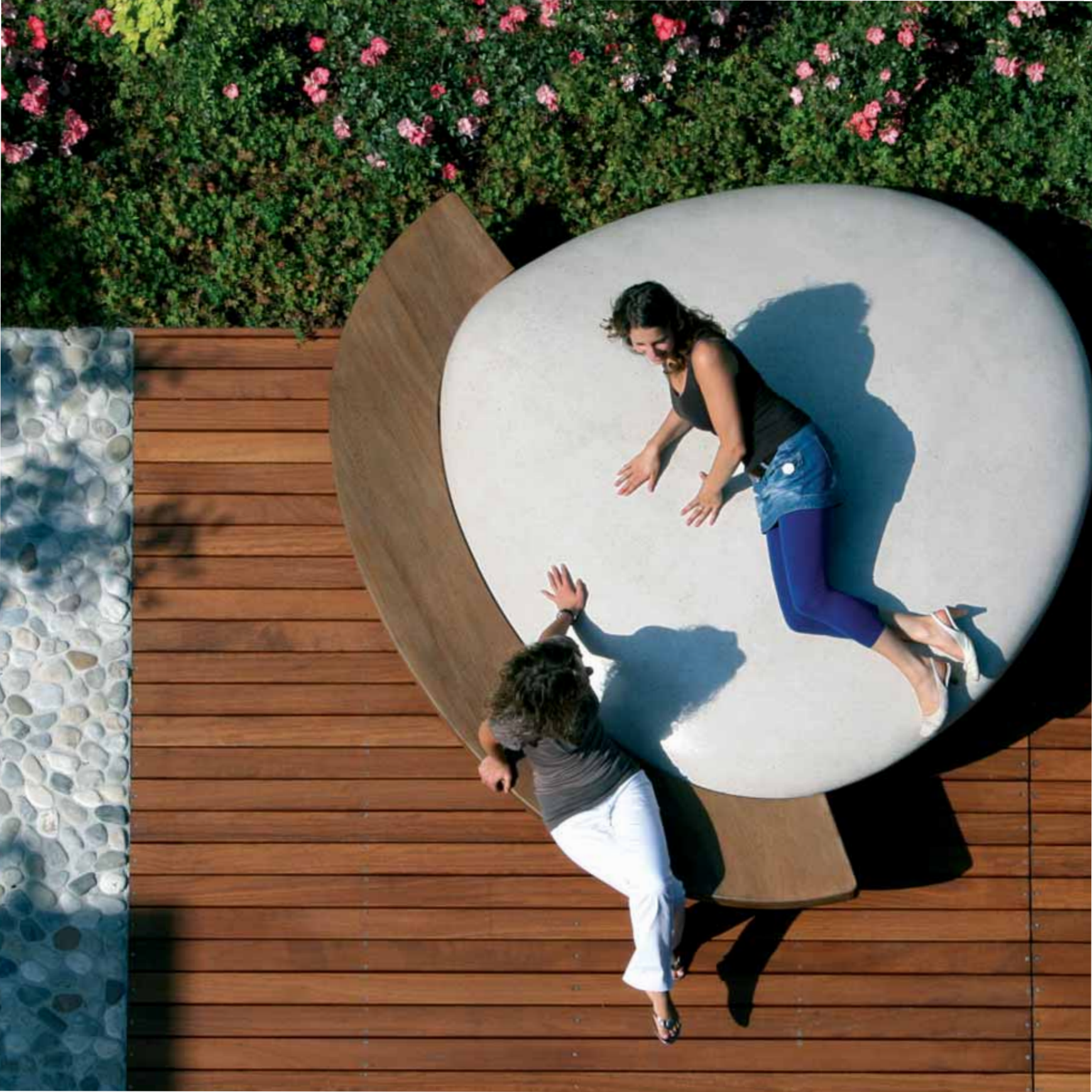

MOONSTONE

PAMIO DESIGN

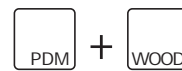

MATERIALS:

RECONSTITUTED STONES + OKOUME

FINISHES:

p. 975

FIXINGS:

BELOW GROUND INSTALLATION

DRAWINGS: p. 912



MOONSTONE

PAMIO DESIGN





NATURAL PUZZLE

DESIGN PIO & TITO TOSO



MATERIALS:

HIGH PERFORMANCE CONCRETE + POWDER COATED STEEL

FINISHES:

p. 977

FIXINGS:

BELOW GROUND INSTALLATION WITH THREADED BARS

DRAWINGS: p. 912





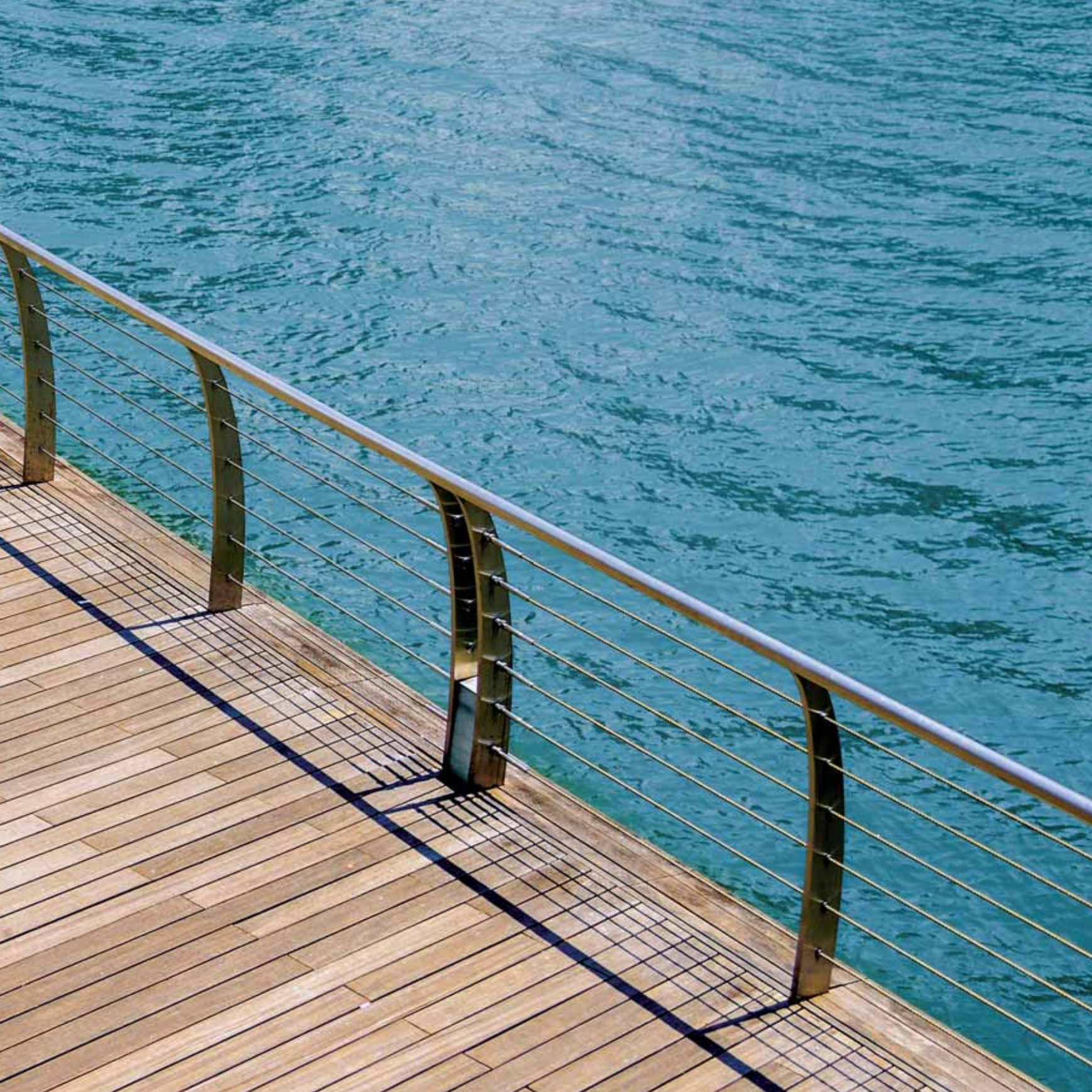





NUVOLA

DESIGN ALFREDO TASCA



MATERIALS:

POWDER COATED STEEL OR CORTEN STEEL + LARCH WOOD OR EXOTIC WOOD

FIXINGS:

PRE DRILLED FOR ANCHORS

DRAWINGS: p. 905, 929





PAD

DESIGN STAUBACH & KUCKERTZ



MATERIALS:

HIGH PERFORMANCE CONCRETE + POWDER COATED STEEL

FINISHES:

VELLUTO

FIXINGS:

FREESTANDING WITH PEDESTALS OR INSTALLATION WITH THREADED BARS

DRAWINGS: p. 914









PLATINUM COLLECTION

DESIGN MATTIA LI POMI





PLATINUM

DESIGN MATTIA LI POMI



MATERIALS:

POWDER COATED STEEL + POWDER COATED ALUMINUM

FIXINGS:

FREESTANDING WITH PEDESTALS OR INSTALLATION WITH THREADED BARS

DRAWINGS: p. 924



metaleo





PLATINUM

DESIGN MATTIA LI POMI







PONTE

DESIGN MASSIMO TASCA



MATERIALS:

LARCH WOOD OR EXOTIC WOOD + POWDER COATED ALUMINIUM

FIXINGS:

FREESTANDING WITH PEDESTALS OR INSTALLATION WITH THREADED BARS

DRAWINGS: p. 929







PONTE

DESIGN MASSIMO TASCA







RIVA

DESIGN STAUBACH & KUCKERTZ



MATERIALS:

LARCH WOOD OR EXOTIC WOOD + POWDER COATED ALUMINIUM

FIXINGS:

INSTALLATION WITH THREADED BARS

DRAWINGS: p. 909





RIVOLA

DESIGN PECORARO + ABATE + BRUNAZZI



MATERIALS:

RECONSTITUTED STONES

FINISHES

p. 975

FIXINGS:

FREE STANDING

DRAWINGS: p. 914



RIVOLA

DESIGN PECORARO + ABATE + BRUNAZZI





RIVOLA

DESIGN PECORARO + ABATE + BRUNAZZI







SARAH

DESIGN RAFFAELE LAZZARI



MATERIALS:

RECONSTITUTED STONES

FINISHES:

SMOOTH SEAT AND SANDBLASTED SIDES

FIXINGS:

FREE STANDING

DRAWINGS: p. 919







SCULPTURE

DESIGN ALFREDO TASCA



MATERIALS:

LARCH WOOD OR EXOTIC WOOD + POWDER COATED STEEL

FIXINGS:

PRE DRILLED FOR ANCHORS

DRAWINGS: p. 906





SEDIS COLLECTION

DESIGN ANTONIO CITTERIO CON TOAN NGUYEN



MURPARK
Gutscheine



SEDIS, SEDIS TORSION

DESIGN ANTONIO CITTERIO CON TOAN NGUYEN



MATERIALS:

OKOUME + POWDER COATED ALUMINIUM

FIXINGS:

PREDRILLED FOR ANCHORS OR BELOW GROUND

DRAWINGS: p. 909

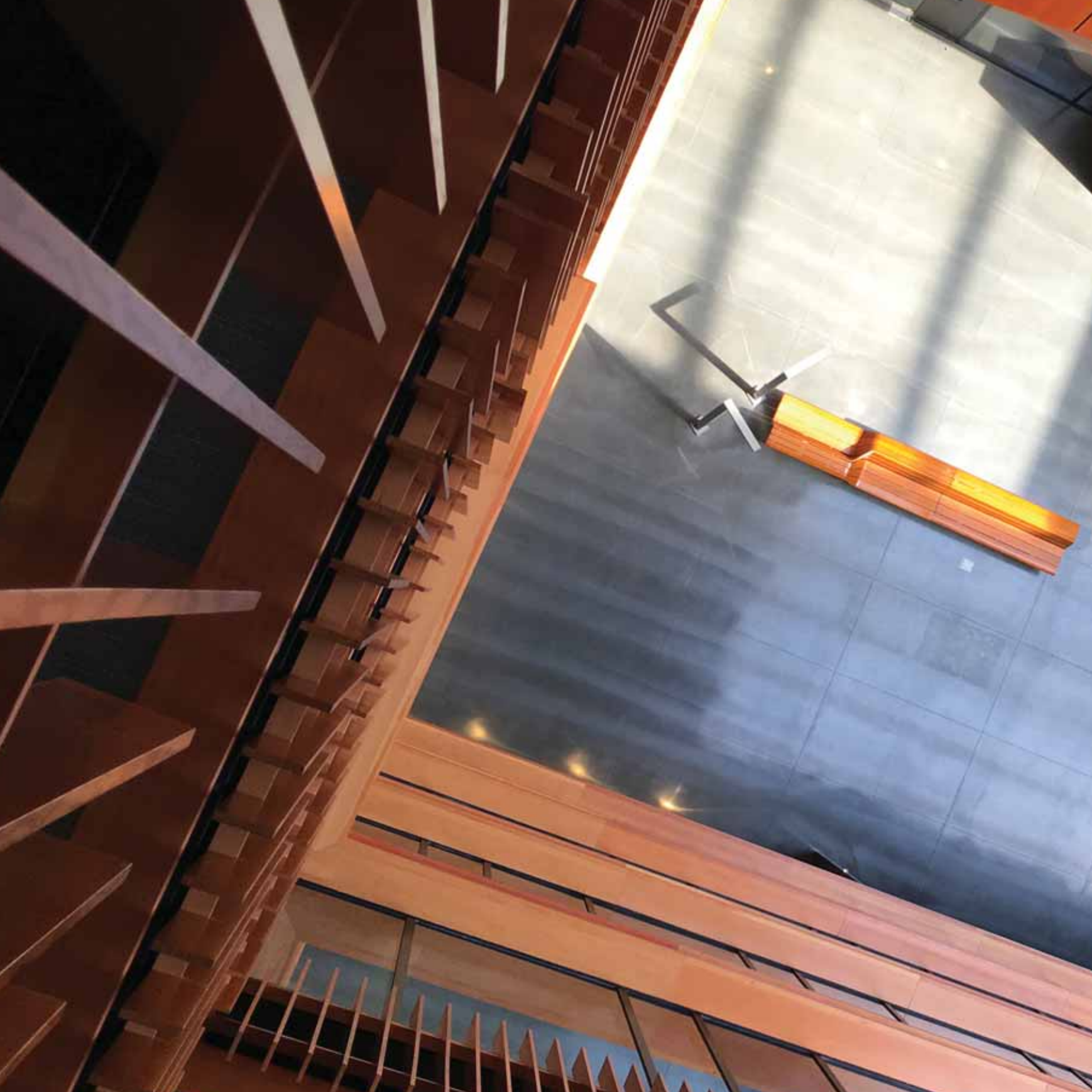





SEDIS, SEDIS TORSION

DESIGN ANTONIO CITTERIO CON TOAN NGUYEN







2007, ADI DESIGN INDEX®
AND "COMPASSO D'ORO



2008, XXI EDITION OF
PREMIO COMPASSO D'ORO:
SEDIS BENCH (DESIGN:
ANTONIO CITTERIO WITH
TOAN NGUYEN)

SEDIS, SEDIS TORSION

DESIGN ANTONIO CITTERIO CON TOAN NGUYEN











STONE

DESIGN RAFFAELE LAZZARI



MATERIALS:

HIGH PERFORMANCE CONCRETE OR ULTRA HIGH PERFORMANCE CONCRETE

FINISHES:

VELLUTO (HPC)
ALFA - PSI (UHPC)

FIXINGS:

FREESTANDING WITH PEDESTALS OR INSTALLATION WITH THREADED BARS

DRAWINGS: p. 913



STONE

DESIGN RAFFAELE LAZZARI







TOSO

DESIGN PIO & TITO TOSO



MATERIALS:

POWDER COATED STEEL

FIXINGS:

PREDRILLED FOR ANCHORS OR INSTALLATION WITH THREADED BARS

DRAWINGS: p. 906



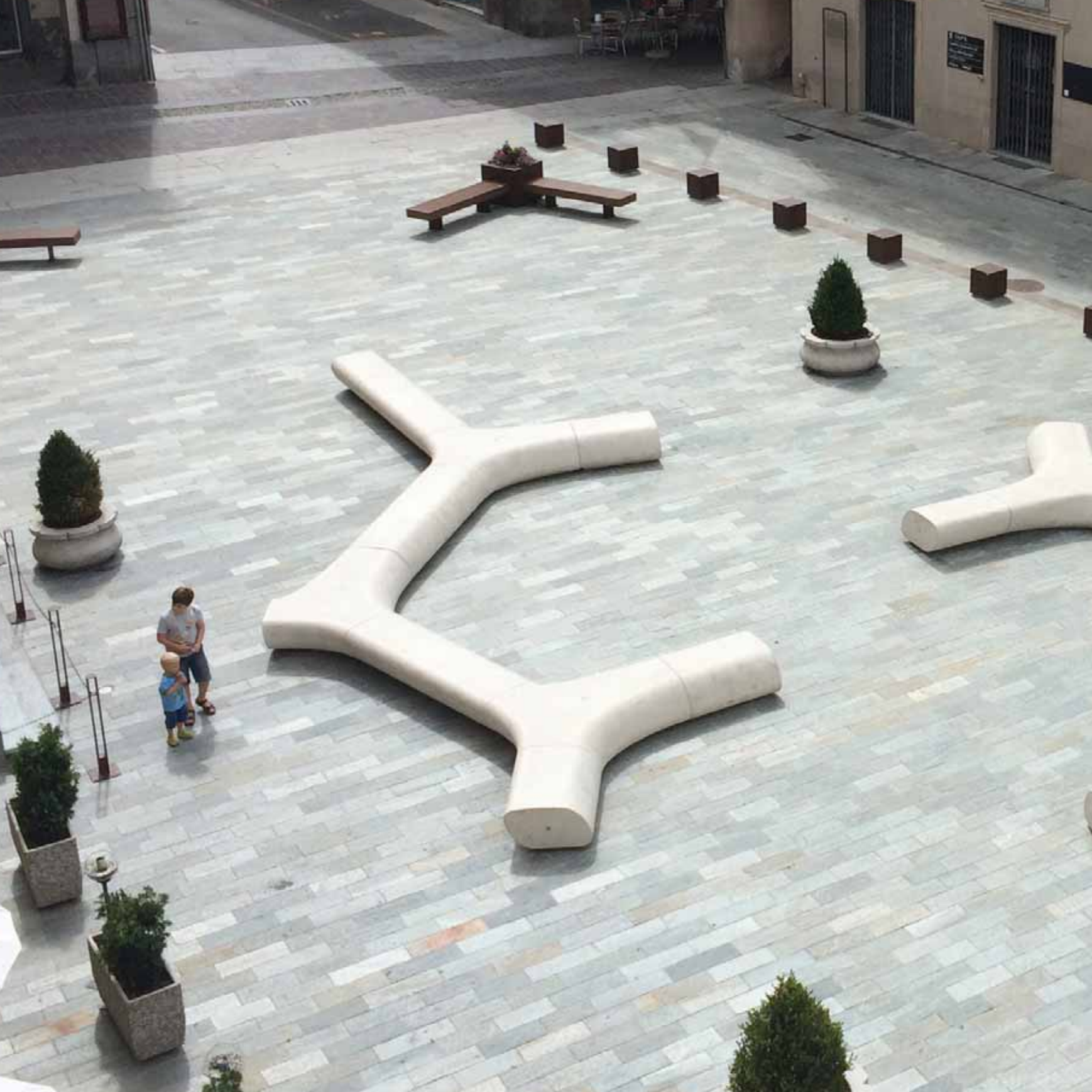



TREE LINE

DESIGN PIO & TITO TOSO



T11



TRL3



TRL 1S



TL 2S





TRLS



TRLY



TREE LINE

DESIGN PIO & TITO TOSO



MATERIALS:

RECONSTITUTED STONES

FINISHES:

p. 975

FIXINGS:

FREE STANDING

DRAWINGS: p. 911





TREE LINE

DESIGN PIO & TITO TOSO





TREE LINE

DESIGN PIO & TITO TOSO









POUF 1900



POUF 2700



DIVANO 1900



DIVANO 2700





TRONO 2700



WSU 1



WSU 2

TRONO, POUF, DIVANO

DESIGN WEST8



MATERIALS:

EXOTIC WOOD + POWDER COATED STEEL

FIXINGS:

PREDRILLED FOR ANCHORS OR BELOW GROUND INSTALLATION

DRAWINGS: p. 920





TRONO, POUF, DIVANO

DESIGN WEST8





TRONO, POUF, DIVANO

DESIGN WEST8





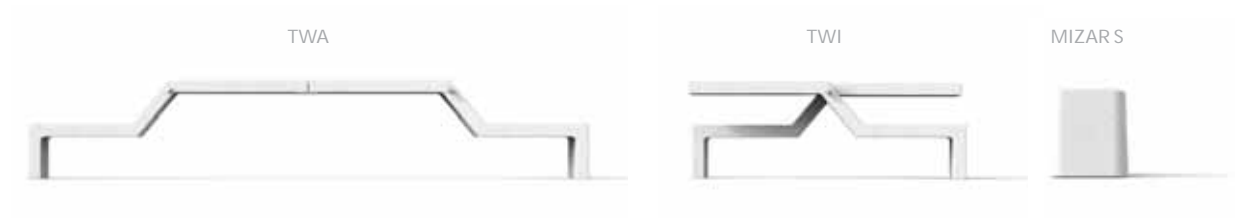

TWIN

DESIGN MASSIMO TASCA



MATERIALS:

HIGH PERFORMANCE CONCRETE

FINISHES:

VELLUTO

FIXINGS:

INSTALLATION WITH THREADED BARS

DRAWINGS: p. 919 (TWA, TWI) - 914 (MIZARS)



TWIN

DESIGN MASSIMO TASCA











ULURU COLLECTION

DESIGN ANDREA MORGANTE + SHIRO STUDIO



ULURU PB

ULURU PA

ULURU T



ULURU COLLECTION

DESIGN ANDREA MORGANTE + SHIRO STUDIO

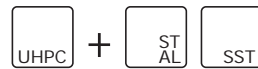

MATERIALS:
ULTRA HIGH PERFORMANCE CONCRETE+ POWDER COATED
STEEL OR POWDER COATED STAINLESS STEEL

FINISHES:
ALFA

FIXINGS:
FREESTANDING WITH PEDESTALS OR INSTALLATION WITH
THREADED BARS

DRAWINGS: p. 918

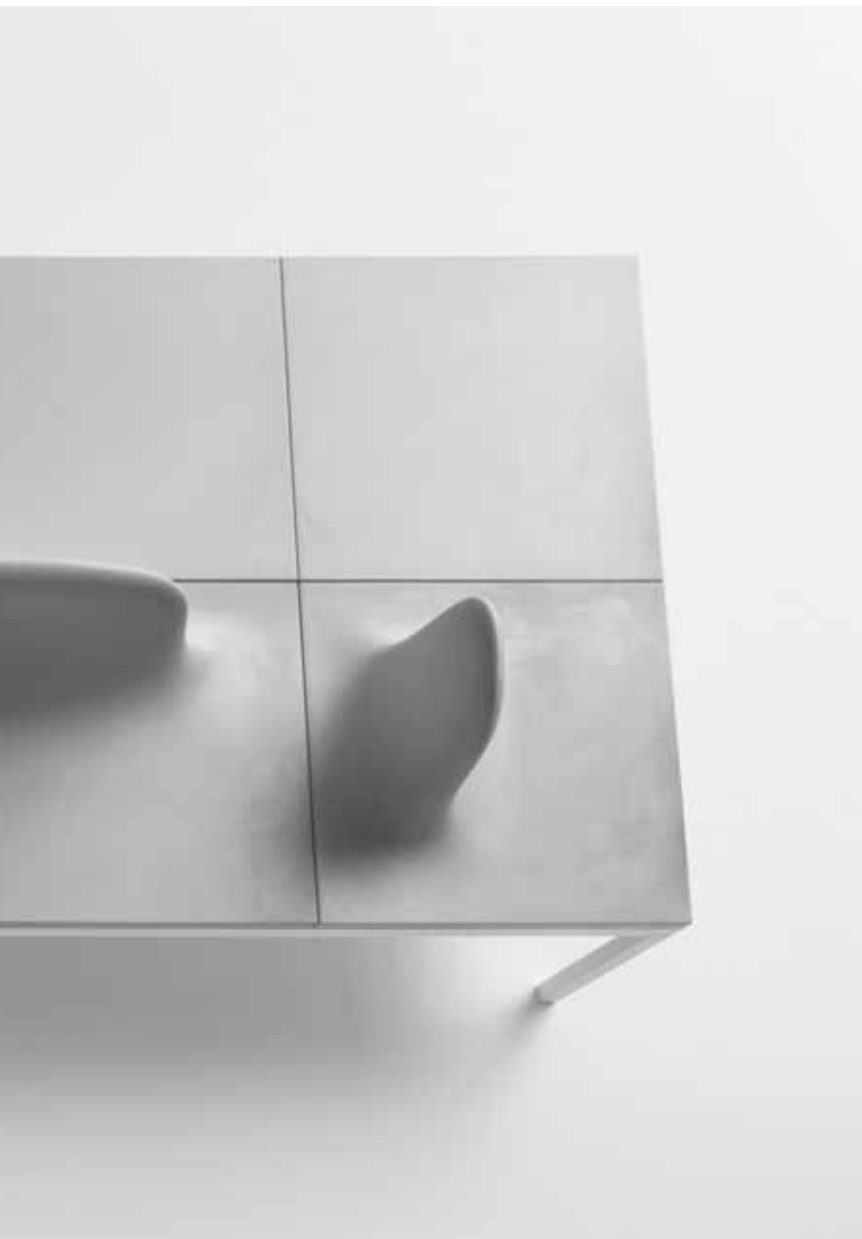



ULURU COLLECTION

DESIGN ANDREA MORGANTE + SHIRO STUDIO





ULURU COLLECTION

DESIGN ANDREA MORGANTE + SHIRO STUDIO

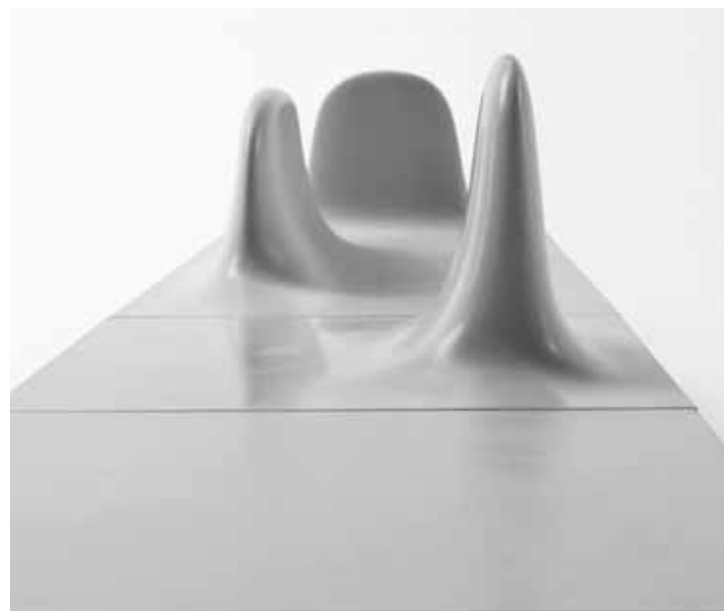





UP

DESIGN PIO & TITO TOSO



MATERIALS:

HIGH PERFORMANCE CONCRETE

FINISHES: VELLUTO

FIXINGS:

FREE STANDING

DRAWINGS: p. 912







UP

DESIGN PIO & TITO TOSO







VP



VD



VG

VALENCIA

DESIGN ALFREDO TASCA



MATERIALS:

LARCH WOOD OR EXOTIC WOOD + POWDER COATED STEEL

FIXINGS:

PRE DRILLED FOR ANCHORS

DRAWINGS: p. 909







VICTOR

DESIGN ALFREDO TASCA



MATERIALS:

LARCH WOOD OR EXOTIC WOOD + POWDER COATED STEEL

FIXINGS:

FREESTANDING WITH PEDESTALS OR INSTALLATION WITH THREADED BARS

DRAWINGS: p. 929





A photograph of a modern outdoor lounge area. The scene is dominated by a large, light-colored concrete overhang that creates a shaded space. Below the overhang, a wooden deck is furnished with several benches. One bench is dark brown, while others are a lighter, warm brown. A person is sitting on one of the lighter brown benches in the background. The background is filled with lush green trees under a clear blue sky. The overall aesthetic is clean, minimalist, and contemporary.

VOLO COLLECTION
DESIGN ALESSANDRO LENARDA



VOLO COLLECTION

DESIGN ALESSANDRO LENARDA



MATERIALS:

COATED STEEL OR CORTEN STEEL

FIXINGS:

PRE DRILLED FOR ANCHORS

DRAWINGS: p. 922

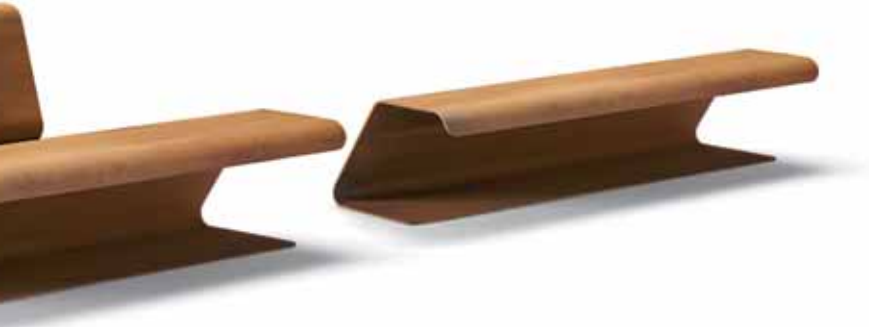



VOLO COLLECTION

DESIGN ALESSANDRO LENARDA

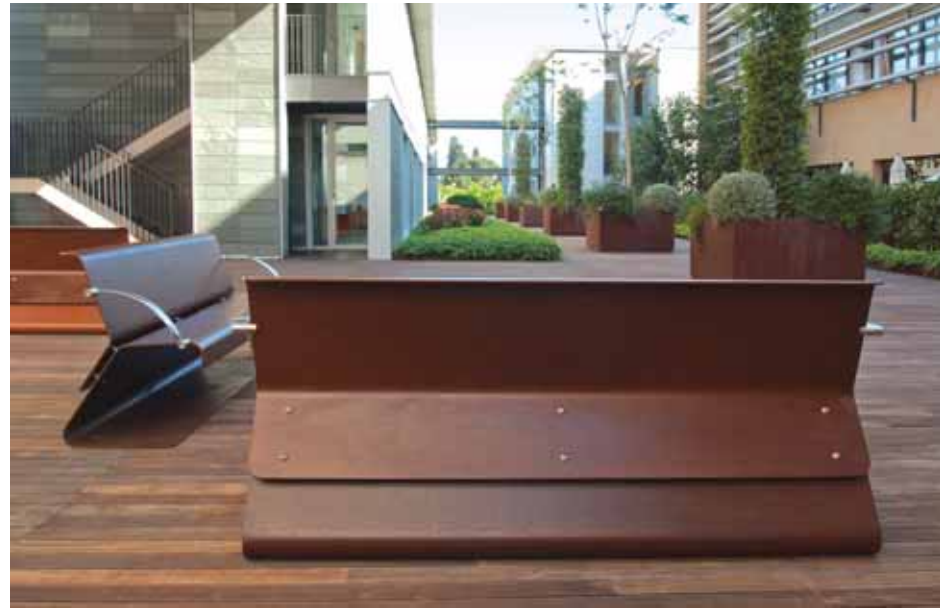

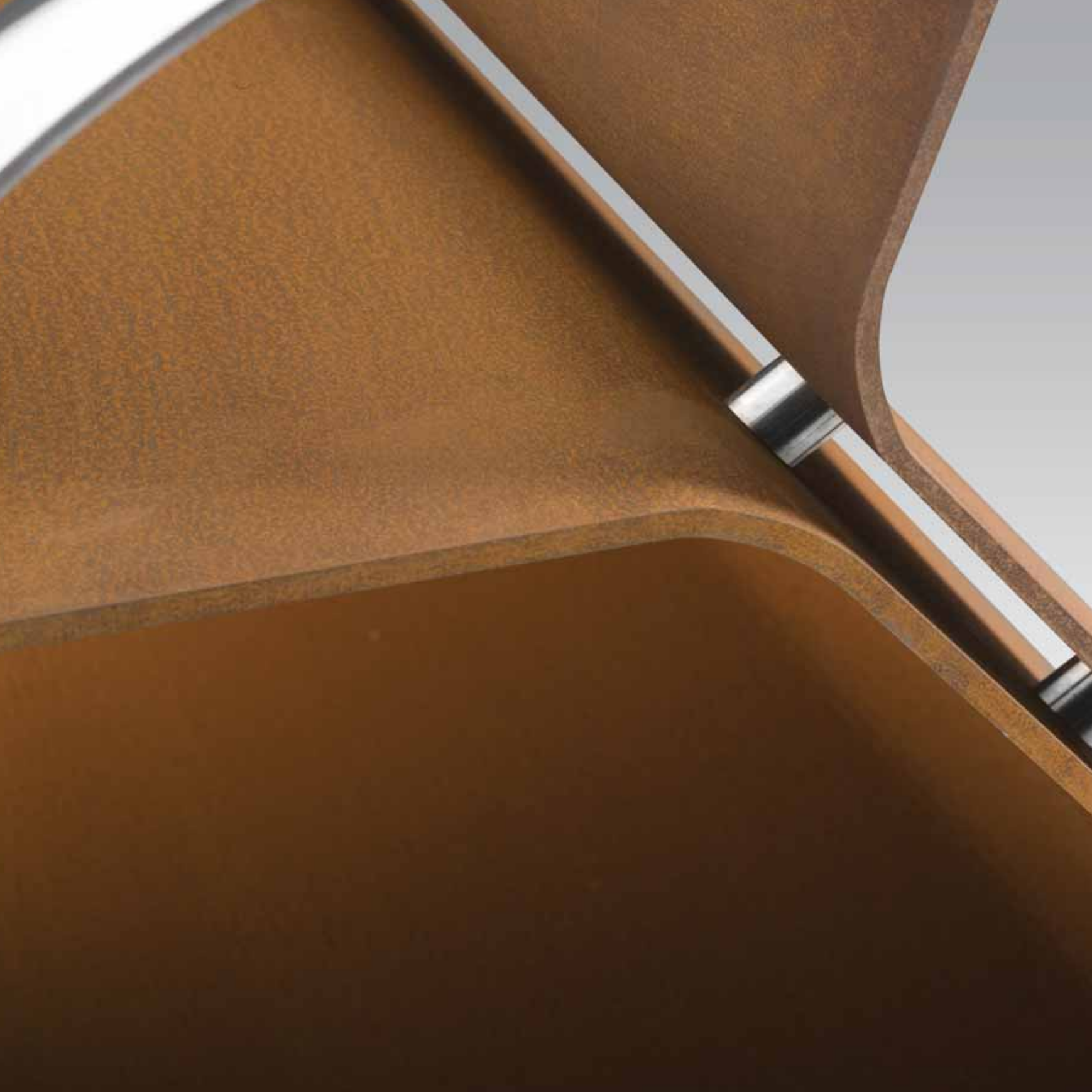

VOLO COLLECTION

DESIGN ALESSANDRO LENARDA

Product: VOLO bench (Design: Alessandro Lenarda)

Included in the "COLLEZIONE FARNESINA DESIGN", travelling exhibition, Rome and Worldwide:

- January 2010: Casa Italia, XXII Winter Olympics Games, Vancouver
 - June 2010: Casa Azzurri FIFA World Cup, Pretoria
 - November 2010: Culture European Capital, Istanbul
 - February-April 2011: Holon National Museum, Tel Aviv
 - May-September 2011: Ara Pacis Museum, Rome
 - November 2011: Palais des Rais, Algeri
 - December 2011-January 2012: Centre National d'Art Vivant, Tunisi
 - February 2012: Ecole Nationale d'Architecture, Rabat
 - July 2012: "Ecosoluzioni/Design del quotidiano", Museum Musiikkitalo, Helsinki
 - July-August 2012: "Queen Elizabeth II Conference Center", Olympics Games, London
 - October-November 2012: "Ecosoluzioni/Design del quotidiano", Slovenian Museum, Lubjjan
 - October-November 2012: Italian cultural Institute "Palazzo della Farnesina e le sue collezioni", Rome
-
- Exposed at Design Museum Holon, Tel Aviv (permanent exhibition)
 - Exposed at Modern and Contemporary Art Gallery, Roma Capitale



PICNIC AREA





A photograph of a person sitting on a wooden bench in a park. The person is seen from behind, wearing a light blue shirt and dark pants. They are sitting on a bench that is part of a set of two. In the background, there is a calm lake reflecting the sky and trees. To the left, a large, leafy tree with thick branches dominates the upper half of the frame. The sun is shining from the left, creating a bright glow and long shadows on the grass. Other people are visible in the distance: two people sitting on the grass near the water's edge, and a group of people sitting on a bench further back. The overall atmosphere is peaceful and serene.

AIR COLLECTION





AIR - L

DESIGN ALFREDO TASCA - MASSIMO TASCA
RAFFAELE LAZZARI



MATERIALS:

LARCH WOOD OR EXOTIC WOOD + POWDER COATED STEEL

FIXINGS:

FREESTANDING WITH PEDESTALS OR INSTALLATION WITH THREADED BARS

DRAWINGS: p. 907

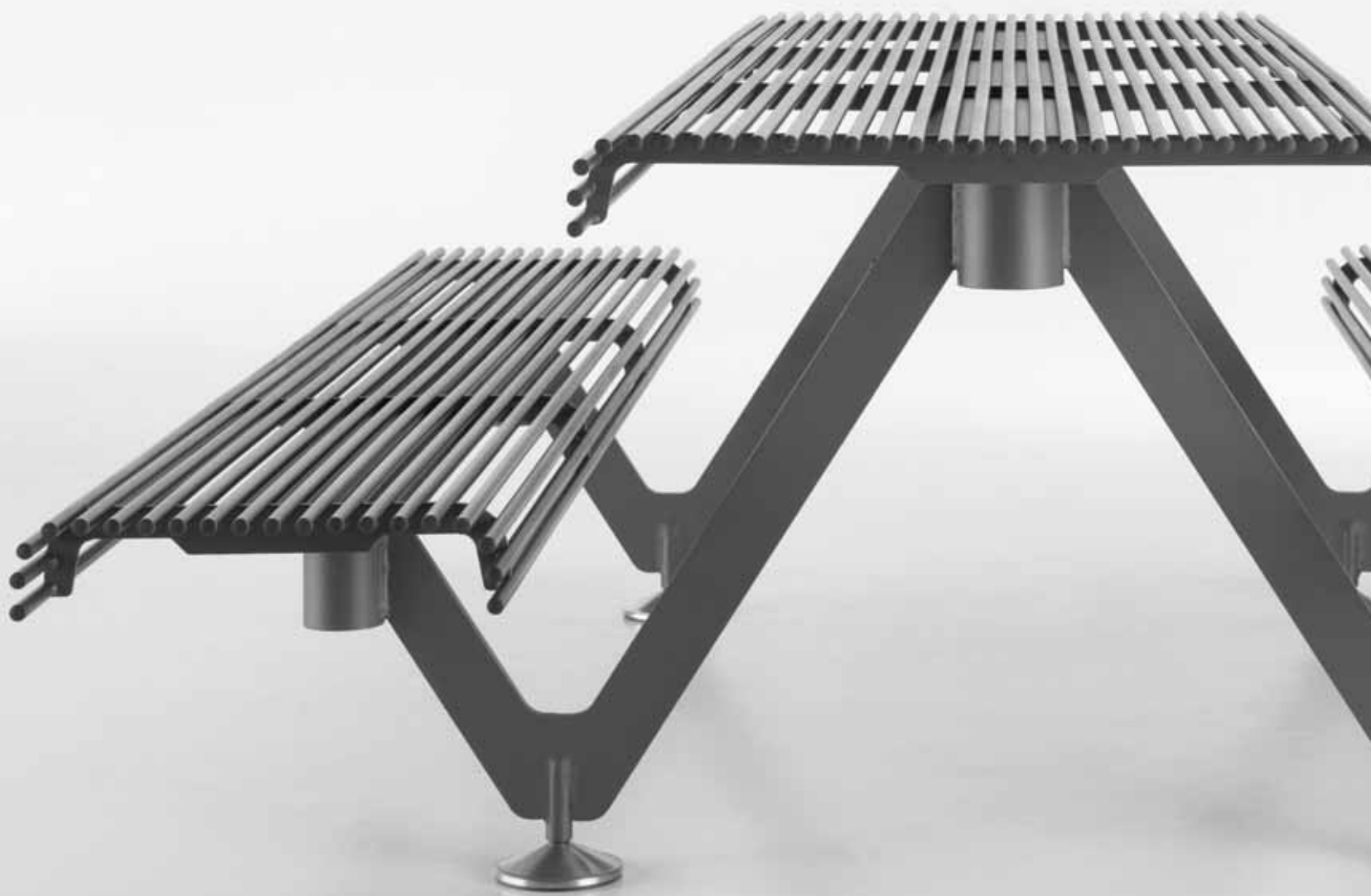



AIR - A

DESIGN ALFREDO TASCA - MASSIMO TASCA
RAFFAELE LAZZARI



MATERIALS:

POWDER COATED STEEL

FIXINGS:

FREESTANDING WITH PEDESTALS OR INSTALLATION WITH THREADED BARS

DRAWINGS: p. 907

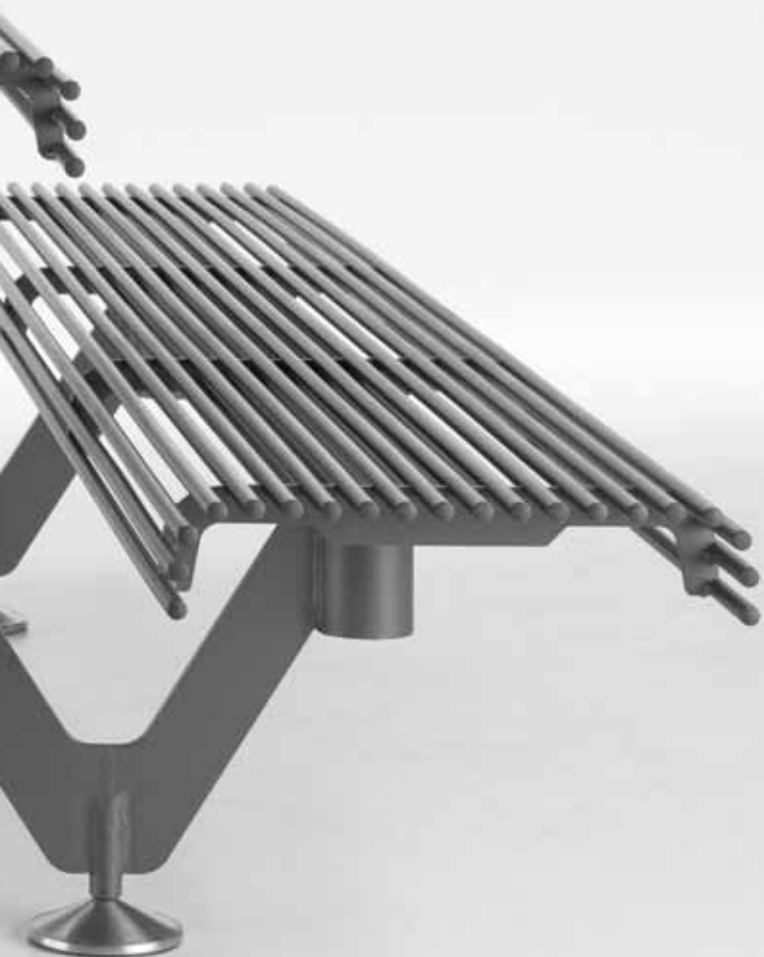





AIR - CS



AIR - C

AIR - C

DESIGN ALFREDO TASCA - MASSIMO TASCA
RAFFAELE LAZZARI



MATERIALS:

ULTRA HIGH PERFORMANCE CONCRETE + POWDER COATED STEEL

FINISHES:

ALFA

FIXINGS:

FREESTANDING WITH PEDESTALS OR INSTALLATION WITH THREADED BARS

DRAWINGS: p. 907



AIR - C

DESIGN ALFREDO TASCA - MASSIMO TASCA
RAFFAELE LAZZARI

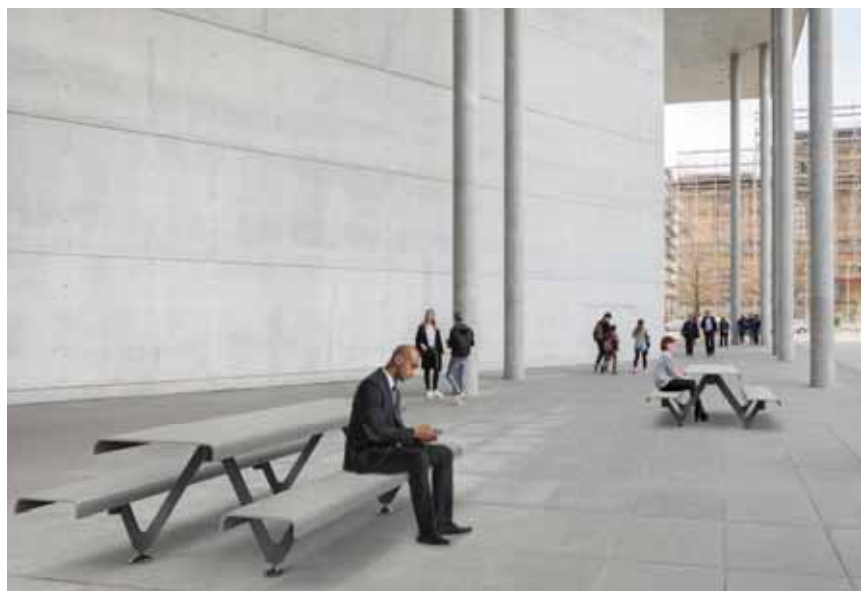





B-B SASS

DESIGN STAUBACH & KUCKERTZ



MATERIALS:

CORTEN STEEL + STAINLESS STEEL + GALVANISED

FIXINGS:

FREE STANDING

DRAWINGS: p. 905

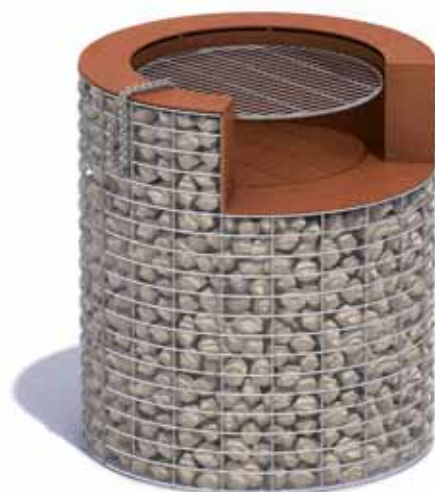



B-BQ

DESIGN MASSIMO TASCA



MATERIALS:

CORTEN STEEL + STAINLESS STEEL

FIXINGS:

BELOW GROUND INSTALLATIONS

DRAWINGS: p. 905





C-BQ

DESIGN MASSIMO TASCA



MATERIALS:

CORTEN STEEL + STAINLESS STEEL

FIXINGS:

FREESTANDING WITH PEDESTALS OR INSTALLATION WITH THREADED BARS

DRAWINGS: p. 905







MERENDA

DESIGN ALESSANDRO LENARDA



MATERIALS:

POWDER COATED STEEL OR CORTEN STEEL + TEAK WOOD

FIXINGS:

PRE DRILLED FOR ANCHORS

DRAWINGS: p. 905







PIC BULL

DESIGN SJIT



MATERIALS:

LARCH WOOD OR EXOTIC WOOD + POWDER COATED STEEL OR
CORTEN STEEL OR STAINLESS STEEL

FIXINGS:

PRE DRILLED FOR ANCHORS

DRAWINGS: p. 906







PIC BULL

DESIGN SJIT







PIC NIC

DESIGN ALFREDO TASCA + MARCO DE LUCA

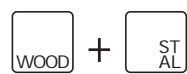

MATERIALS:

LARCH WOOD OR EXOTIC WOOD + POWDER COATED STEEL

FIXINGS:

PRE DRILLED FOR ANCHORS

DRAWINGS: p. 905



**l'Olio Nuovo
in Festa**

7 - 9 dicembre 2012





SIL

METALCO DESIGN



MATERIALS:

GALVANISED STEEL + OXIDIZED STEEL + STAINLESS STEEL
+ ALUMINIUM COMPOSITE PANEL

FIXINGS:

BELOW GROUND INSTALLATION

DRAWINGS: p. 953



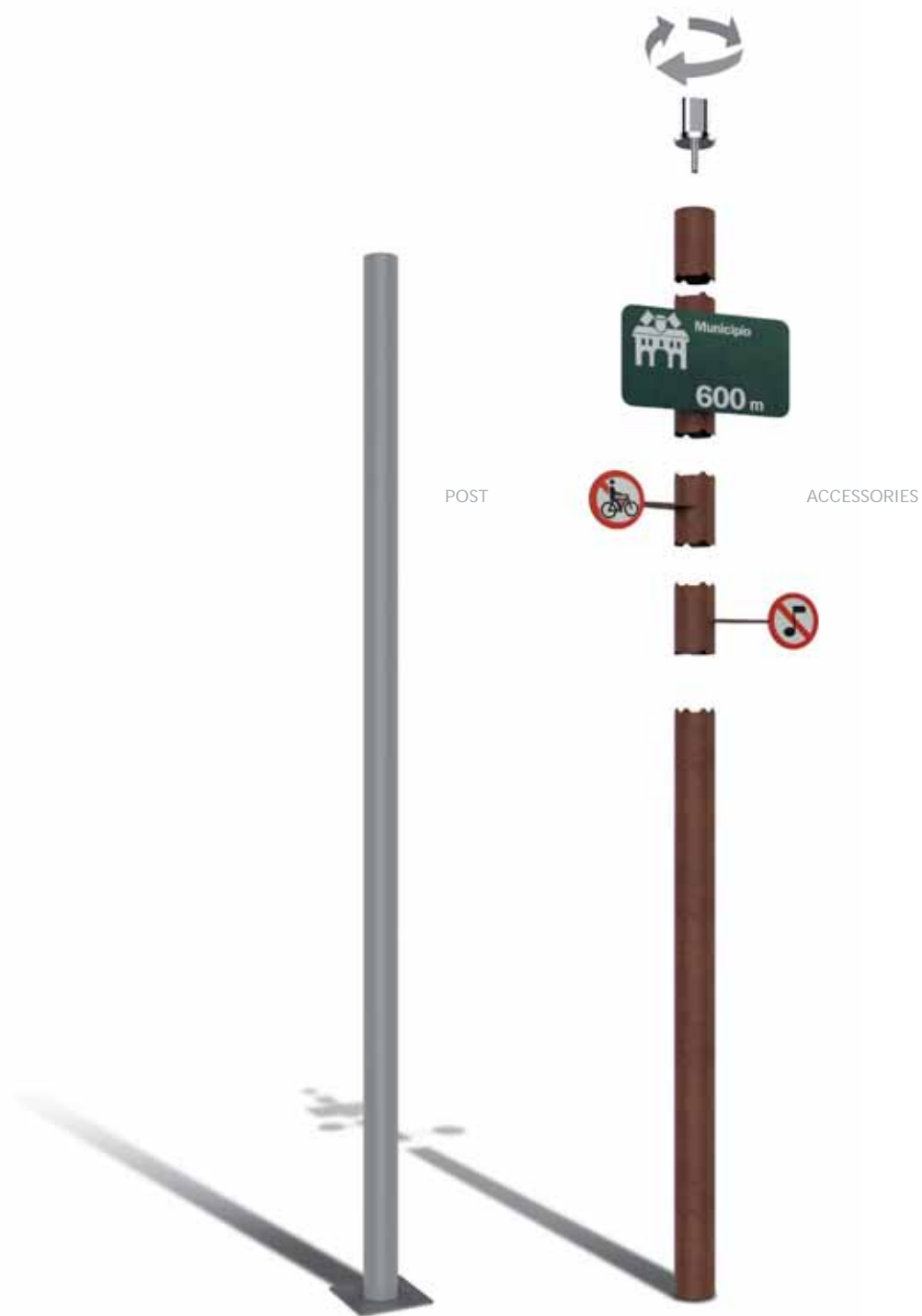

SIL

METALCO DESIGN

UTI / WASTE





LITTER BINS

 Aeroporti
di Roma

CARTA / PAPER

RIFIUTI / WASTE

PLASTICA / PLASTIC



A3

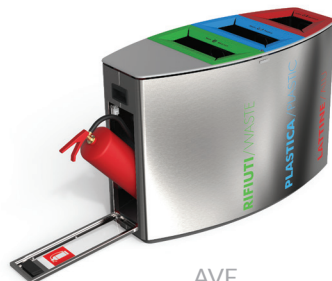

AVF



A4

AERO

DESIGN ALFREDO TASCA + ANTONIO AMENDOLA +
ELVIRA CERRATTI + RAFFAELE LAZZARI



MATERIALS:

POWDER COATED STEEL OR STAINLESS STEEL + POWDER COATED

A3	-	2x50,	1x65	lt
A4	-	2x50,	2x60	lt
AVF - 1x50, 2x60 lt				

FIXINGS:

FREE STANDING (INDOOR ONLY)

DRAWINGS: p. 934



AERO

DESIGN ALFREDO TASCA + ANTONIO AMENDOLA +
ELVIRA CERRATTI + RAFFAELE LAZZARI





AERO

DESIGN ALFREDO TASCA + ANTONIO AMENDOLA +
ELVIRA CERRATTI + RAFFAELE LAZZARI

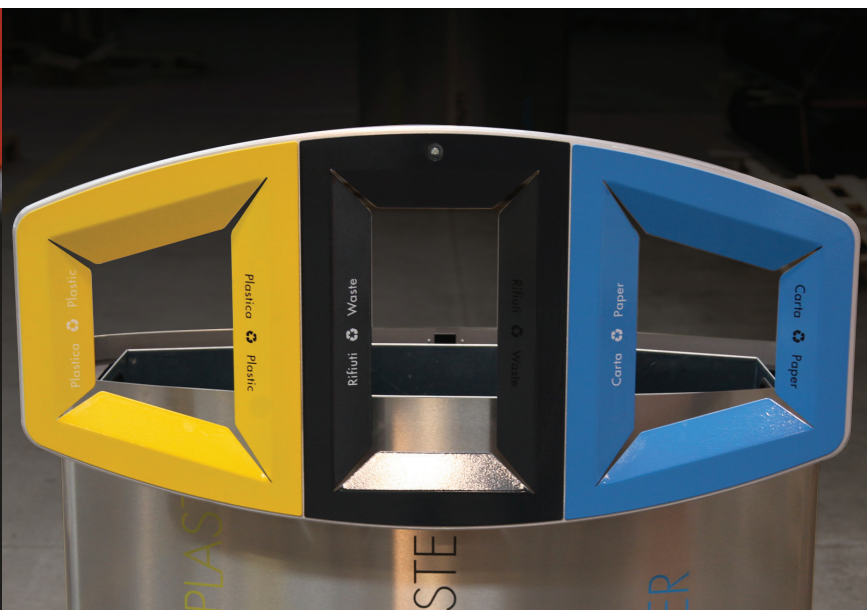

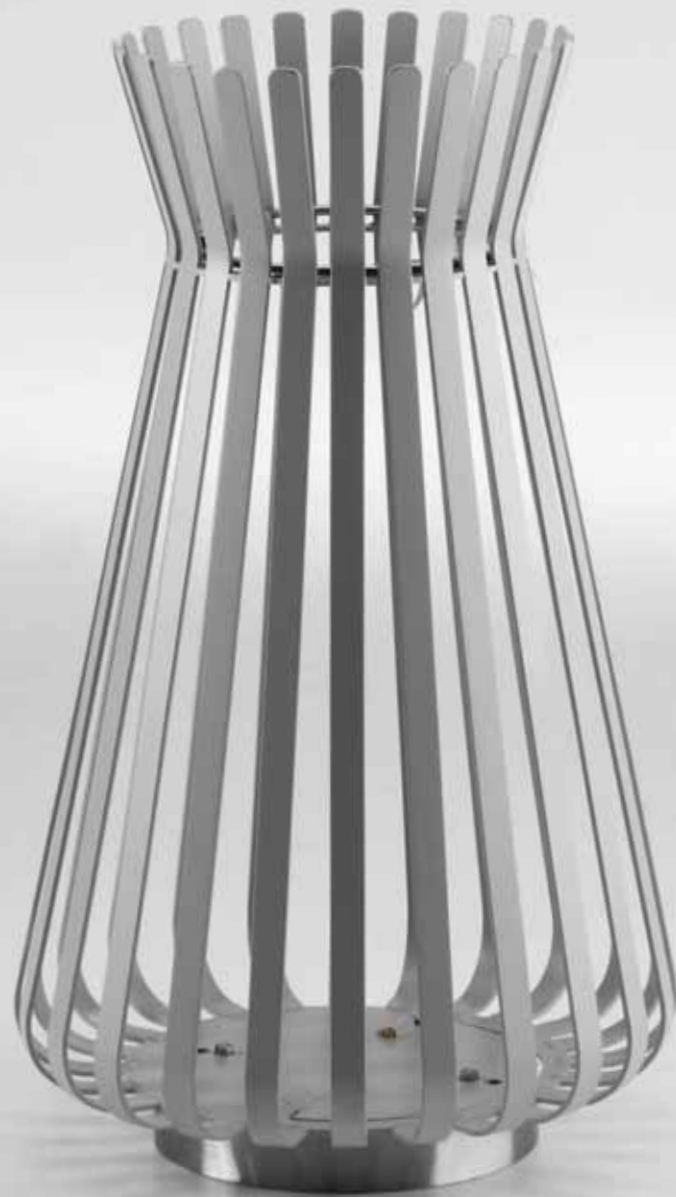



ANFORA

DESIGN SABRINA TUBIA



MATERIALS:

POWDER COATED STEEL

70/95 lt

FIXINGS:

PRE DRILLED FOR ANCHORS

DRAWINGS: p. 930



Danubial

MEULENSTEEN ART MU





LITTER BINS



A



S



O

BLADES

DESIGN STAUBACH & KUCKERTZ



MATERIALS:

POWDER COATED STEEL

42 It

FIXINGS:

PRE DRILLED FOR ANCHORS

DRAWINGS: p. 935



BLOOM

DESIGN ALFREDO TASCA



MATERIALS:

POWDER COATED STEEL OR CORTEN STEEL STEEL

80 lt

FIXINGS:

PRE DRILLED FOR ANCHORS

DRAWINGS: p. 934





BLOOM

DESIGN ALFREDO TASCA







BOTTE

DESIGN MATTIA LI POMI

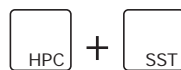

MATERIALS:

HIGH PERFORMANCE CONCRETE + STAINLESS STEEL

FINISHES:

VELLUTO
85 lt

FIXINGS:

PRE DRILLED FOR ANCHORS

DRAWINGS: p. 930



BOTTE

DESIGN MATTIA LI POMI





GAVITELLO

DESIGN RAFFAELE LAZZARI

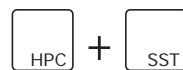

MATERIALS:

HIGH PERFORMANCE CONCRETE + STAINLESS STEEL

FINISHES:

VELLUTO
85 lt

FIXINGS:

PRE DRILLED FOR ANCHORS

DRAWINGS: p. 930



GAVITELLO

DESIGN RAFFAELE LAZZARI







BOX

DESIGN STAUBACH & KUCKERTZ



MATERIALS:

POWDER COATED STEEL + TEAK WOOD OR POWDERCOATED STEEL

55 / 110 / 150 lt

FIXINGS:

PRE DRILLED FOR ANCHORS

DRAWINGS: p. 933





BOX

DESIGN STAUBACH & KUCKERTZ







SUPERBRAVO

DESIGN MASSIMO TASCA - MATTIA LI POMI



MATERIALS:

POWDER COATED STEEL + STAINLESS STEEL

35 lt

FIXINGS:

PREDRILLED FOR ANCHORS OR BELOW GROUND INSTALLATION

DRAWINGS: p. 932





RESÍDUOS
ORGÂNICOS





BRAVO SLIK, HOLE

METALCO DESIGN



MATERIALS:

POWDER COATED STEEL OR STAINLESS STEEL

35 lt

FIXINGS:

PREDRILLED FOR ANCHORS OR BELOW GROUND

DRAWINGS: p. 932







BRAVO BOOM

DESIGN MATTIA LI POMI



MATERIALS:

POWDER COATED STEEL

35 lt

FIXINGS:

PRE DRILLED FOR ANCHORS

DRAWINGS: p. 932

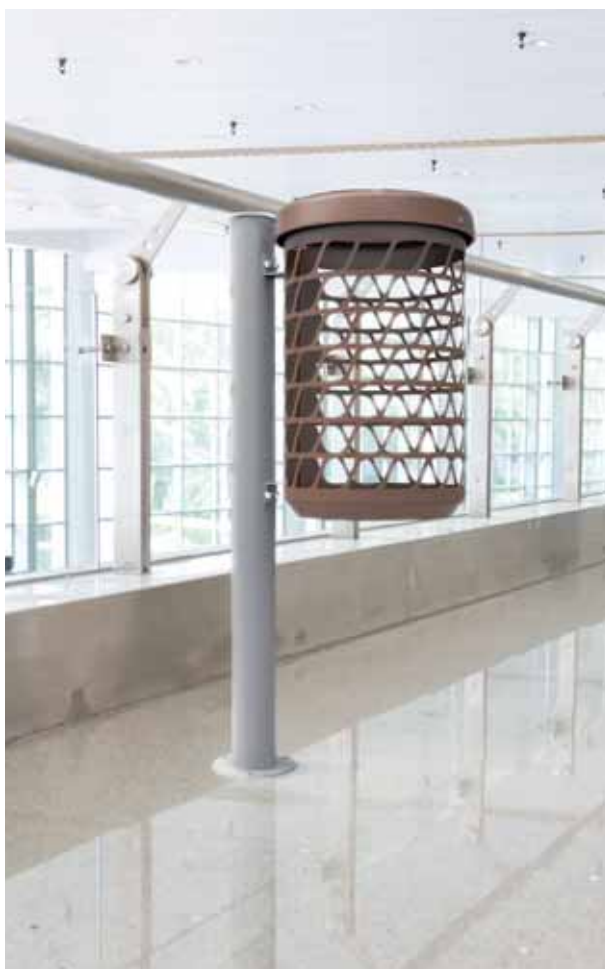



Пластик
PLASTIC



аралас қожығ
MIXED WASTE



Қағаз
PAPER





C3T



C3L

C3

DESIGN ALFREDO TASCA



MATERIALS:

POWDER COATED STEEL

25 / 34 / 43 lt

FIXINGS:

FREE STANDING (INDOOR ONLY)

DRAWINGS: p. 933







CESTIS

DESIGN ANTONIO CITTERIO CON TOAN NGUYEN



MATERIALS:

POWDER COATED STEEL + POWDER COATED ALUMINUM

40 lt

FIXINGS:

PREDRILLED FOR ANCHORS OR BELOW GROUND INSTALLATION

DRAWINGS: p. 931





CESTUM

DESIGN ANTONIO CITTERIO CON TOAN NGUYEN



MATERIALS:

POWDER COATED ALUMINUM + POWDER COATED STEEL

75 lt

FIXINGS:

PRE DRILLED FOR ANCHORS

DRAWINGS: p. 931





CHANDY

METALCO DESIGN



MATERIALS:

POWDER COATED STEEL

60 lt

FIXINGS:

FREESTANDING OR INSTALLATION WITH THREADED BAR

DRAWINGS: p. 934



CLUB C

DESIGN ERIC MANFRINO



MATERIALS:

POWDER COATED STEEL OR CORTEN STEEL

40 lt

FIXINGS:

PRE DRILLED FOR ANCHORS

DRAWINGS: p. 934

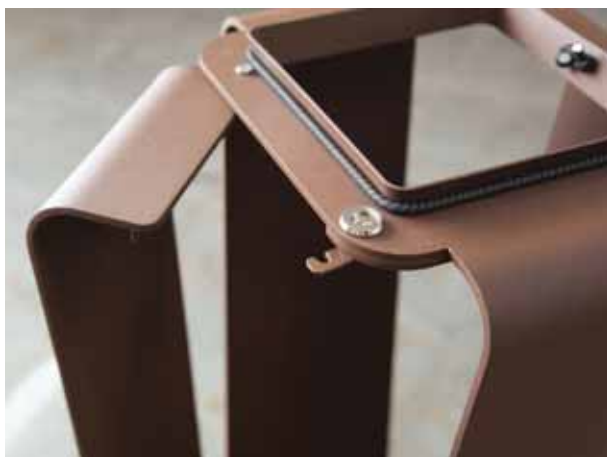





CONGA

AUREL DESIGN URBAIN



MATERIALS:

POWDER COATED STEEL OR CORTEN STEEL

30 lt

FIXINGS:

PRE DRILLED FOR ANCHORS

DRAWINGS: p. 932





CORTE

DESIGN BETANCOURTDESIGN



MATERIALS:

POWDER COATED STEEL OR CORTEN STEEL

55 lt

FIXINGS:

PREDRILLED FOR ANCHORS OR BELOW GROUND INSTALLATION

DRAWINGS: p. 933





CUP

DESIGN STAUBACH & KUCKERTZ

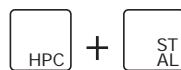

MATERIALS:

HIGH PERFORMANCE CONCRETE + POWDER COATED STEEL

FINISHES:

VELLUTO

68 lt

FIXINGS:

PRE DRILLED FOR ANCHORS

DRAWINGS: p. 930





ECOMIX

DESIGN RAFFAELE LAZZARI



MATERIALS:

POWDER COATED STEEL OR STAINLESS STEEL OR CORTEN
STEEL+ POWDER COATED ALUMINUM

200 lt

FIXINGS:

PRE DRILLED FOR ANCHORS

DRAWINGS: p. 933





ECOMIX

DESIGN RAFFAELE LAZZARI

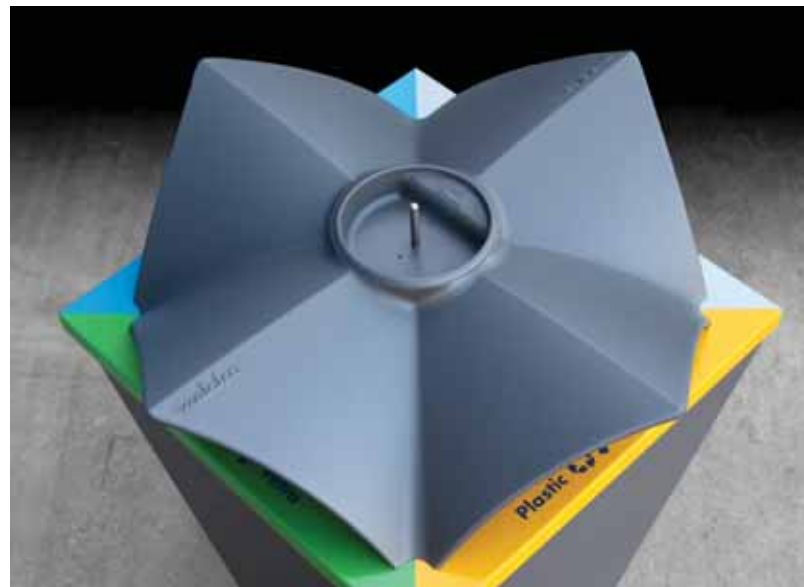





ECOSIDE

DESIGN ALFREDO TASCA



MATERIALS:

POWDER COATED STEEL OR STAINLESS STEEL

70 / 100 lt

FIXINGS:

PRE DRILLED FOR ANCHORS

DRAWINGS: p. 935







ECOSPENCER

DESIGN ALFREDO TASCA



MATERIALS:

POWDER COATED STEEL

3x25 lt

FIXINGS:

PRE DRILLED FOR ANCHORS

DRAWINGS: p. 936





MC 110

EC 75

M 110

E 75

ERCOLE + MILLENNIUM

DESIGN ALFREDO TASCA



MATERIALS:

POWDER COATED STEEL

75 / 110 lt

FIXINGS:

FREE STANDING OR PREDRILLED FOR ANCHORS

DRAWINGS: p. 931





ERMES

DESIGN STAUBACH & KUCKERTZ



MATERIALS:

POWDER COATED STEEL OR STAINLESS STEEL

55 lt

FIXINGS:

PREDRILLED FOR ANCHORS OR BELOW GROUND INSTALLATION

DRAWINGS: p. 934





ERMES

DESIGN STAUBACH & KUCKERTZ







FLOM

DESIGN STAUBACH & KUCKERTZ



MATERIALS:

POWDER COATED STEEL

30 lt

FIXINGS:

PRE DRILLED FOR ANCHORS

DRAWINGS: p. 931



HALLS

METALCO DESIGN



MATERIALS:

POWDER COATED STEEL

90 lt

FIXINGS:

FREE STANDING OR PREDRILLED FOR ANCHORS

DRAWINGS: p. 934







LANCILOTTO

METALCO DESIGN



MATERIALS:

POWDER COATED STEEL OR CORTEN STEEL OR STAINLESS STEEL

30 / 45 / 100 lt

FIXINGS:

PREDRILLED FOR ANCHORS OR BELOW GROUND INSTALLATION

DRAWINGS: p. 930





LYS

METALCO DESIGN



MATERIALS:

POWDER COATED STEEL

25 / 50 lt

FIXINGS:

PRE DRILLED FOR ANCHORS

DRAWINGS: p. 931







MARCO BOOM

DESIGN MATTIA LI POMI



MATERIALS:

POWDER COATED STEEL

115 lt

FIXINGS:

PRE DRILLED FOR ANCHORS

DRAWINGS: p. 935







MARTE

METALCO DESIGN



MATERIALS:

POWDER COATED STEEL OR STAINLESS STEEL + POWDER COATED

50 lt

FIXINGS:

PREDRILLED FOR ANCHORS OR BELOW GROUND INSTALLATION

DRAWINGS: p. 934





MASCHERA

DESIGN MASSIMO TASCA



MATERIALS:

COATED STEEL OR CORTEN STEEL

FIXINGS:

PREDRILLED FOR ANCHORS OR BELOW GROUND INSTALLATION

DRAWINGS: p. 942





RIFIUTI/WASTE



PL



PS

PACK

DESIGN MASSIMO TASCA



MATERIALS:

POWDER COATED STEEL

50 / 100 lt



FIXINGS:

FREESTANDING WITH PEDESTALS OR INSTALLATION WITH THREADED BARS

DRAWINGS: p. 935

TI WASTE



PACK

DESIGN MASSIMO TASCA





PARK

METALCO DESIGN



MATERIALS:

POWDER COATED STEEL

75 / 100 lt

FIXINGS:

PRE DRILLED FOR ANCHORS

DRAWINGS: p. 931







POD

DESIGN ANDREA MORGANTE + SHIRO STUDIO

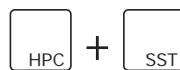

MATERIALS:

HIGH PERFORMANCE CONCRETE + STAINLESS STEEL

FINISHES:

VELLUTO

70 lt

FIXINGS:

PRE DRILLED FOR ANCHORS

DRAWINGS: p. 930





SET

DESIGN STAUBACH & KUCKERTZ



MATERIALS:

POWDER COATED ALUMINUM + POWDER COATED STEEL

3x60 lt

FIXINGS:

FREE STANDING WITH PEDESTALS (INDOOR ONLY)

DRAWINGS: p. 931





Ufficio di Assistenza
Clienti
Biblioteca Online
Servizi di Assistenza
Contatti
112-113
114-115
116-117
118-119
120-121
122-123

QUARZO

METALCO DESIGN

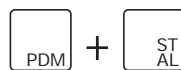

MATERIALS:

RECONSTITUTED STONES + POWDER COATED STEEL

FINISHES:

SANDBLASTED
120 lt

FIXINGS:

FREE STANDING

DRAWINGS: p. 930







QUBA

METALCO DESIGN



MATERIALS:

POWDER COATED STEEL

140 lt

FIXINGS:

PRE DRILLED FOR ANCHORS

DRAWINGS: p. 933



RAINLESS

DESIGN STAUBACH & KUCKERTZ

ONLY 3.2% OF RAINWATER ENTERS THE INTERNAL LINER, FAVOURING INSTEAD THE COLLECTION AND TREATMENT OF LITTER.







RAINLESS

DESIGN STAUBACH & KUCKERTZ



MATERIALS:

POWDER COATED STEEL OR CORTEN STEEL OR STAINLESS STEEL + POWDER COATED STEEL

150 lt

FIXINGS:

PRE DRILLED FOR ANCHORS

DRAWINGS: p. 934



RUBINO

DESIGN STAUBACH & KUCKERTZ

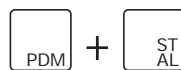

MATERIALS:

RECONSTITUTED STONES + POWDER COATED

FINISHES:

SANDBLASTED
70 lt

FIXINGS:

FREE STANDING

DRAWINGS: p. 930





SINGLE FOX

DESIGN ALFREDO TASCA



MATERIALS:

POWDER COATED STEEL OR STAINLESS STEEL + POWDER COATED ALUMINUM

110 lt

FIXINGS:

FREE STANDING OR PREDRILLED FOR ANCHORS

DRAWINGS: p. 935

Deloitte

Deloitte.

B1

EBU 3



SPENCER COLLECTION

DESIGN ALFREDO TASCA

SPENCER



SPENCER TC



SPENCER E



SPENCER T



SPENCER O



SPENCER R



SPENCER LIBRE

SPENCER ST

SPENCER W



SPENCER COLLECTION

DESIGN ALFREDO TASCA



MATERIALS:

POWDER COATED STEEL OR CORTEN STEEL OR STAINLESS STEEL OR LARCH
WOOD OR EXOTIC WOOD

C 80 / 120 lt
Q 100 lt
E 75 lt
R 65 lt
T 90 lt
TC 80 lt
W 48 lt
LIBRE 75 lt
ST 120 lt

FIXINGS:

PRE DRILLED FOR ANCHORS

DRAWINGS: p. 936







SPENCER COLLECTION

DESIGN ALFREDO TASCA





SPENCER COLLECTION

DESIGN ALFREDO TASCA











CP



CPP



CPQ

SPENCER CP

DESIGN ALFREDO TASCA



MATERIALS:

POWDER COATED STEEL OR CORTEN STEEL OR STAINLESS STEEL

CP 70 / 95 lt

CPQ 85 lt

CPP 45 lt

FIXINGS:

PRE DRILLED FOR ANCHORS

DRAWINGS: p. 936

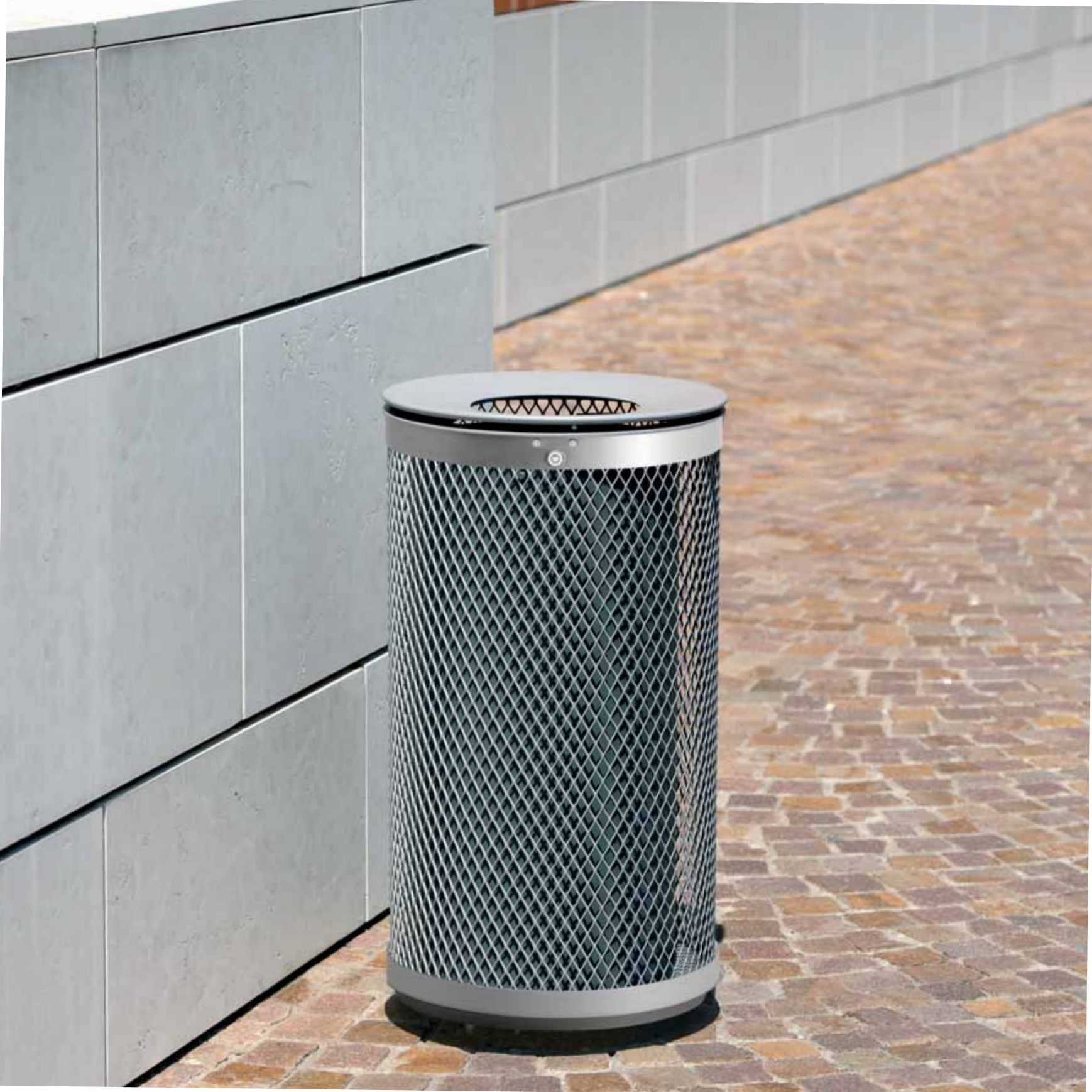



TOM

DESIGN STAUBACH & KUCKERTZ



MATERIALS:

POWDER COATED STEEL

50 lt

FIXINGS:

PRE DRILLED FOR ANCHORS

DRAWINGS: p. 931







TOPAZIO

DESIGN RAFFAELE LAZZARI

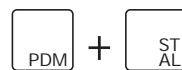

MATERIALS:

RECONSTITUTED STONES + POWDER COATED STEEL + POWDER
COATED ALUMINUM

FINISHES:

SANDBLASTED

130 lt

FIXINGS:

FREE STANDING

DRAWINGS: p. 930





TULIP

DESIGN SABRINA TUBIA



MATERIALS:

POWDER COATED STEEL OR CORTEN STEEL OR STAINLESS STEEL 70 /

108 lt

FIXINGS:

PRE DRILLED FOR ANCHORS

DRAWINGS: p. 934



TULIP

DESIGN SABRINA TUBIA





7872

GET OUR EXPERT
WATCHMAKERS
HELP YOU WITH



- Battery Replacement
- Watch Case and Refinishing
- Watch Crystal Replacement
- Watch Band Replacement
- Professional Cleaning & Polishing





YES

DESIGN ALFREDO TASCA



MATERIALS:

POWDER COATED STEEL OR CORTEN STEEL + TEAK

100 lt

FIXINGS:

PRE DRILLED FOR ANCHORS

DRAWINGS: p. 935





YES

DESIGN ALFREDO TASCA





BIG SPACE

METALCO DESIGN



MATERIALS:

STEEL + POWDER COATED ALUMINUM

FIXINGS:

PRE DRILLED FOR ANCHORS

DRAWINGS: p. 932







CICA

DESIGN NICCOLÒ BAREA



MATERIALS:

POWDER COATED STEEL + STAINLESS STEEL

FIXINGS:

PRE DRILLED FOR ANCHORS

DRAWINGS: p. 935





FU'

DESIGN LUIGI VIALETTA

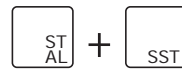

MATERIALS:

POWDER COATED STEEL + STAINLESS STEEL

FIXINGS:

PRE DRILLED FOR ANCHORS

DRAWINGS: p. 932







FUMA

DESIGN ALFREDO TASCA



MATERIALS:

COATED STAINLESS STEEL + STAINLESS STEEL

FIXINGS:

PRE DRILLED FOR ANCHORS

DRAWINGS: p. 932







GENE

DESIGN MASSIMO TASCA



MATERIALS:

POWDER COATED STEEL + STAINLESS STEEL

FIXINGS:

PRE DRILLED FOR ANCHORS

DRAWINGS: p. 935







MO

DESIGN FEDERICO BONAN



MATERIALS:

POWDER COATED STEEL OR CORTEN STEEL + STAINLESS STEEL

FIXINGS:

PRE DRILLED FOR ANCHORS

DRAWINGS: p. 935





SCRAMBLER

DESIGN MATTIA LI POMI



MATERIALS:

POWDER COATED STEEL + STAINLESS STEEL

FIXINGS:

PRE DRILLED FOR ANCHORS

DRAWINGS: p. 935





SCUDO

DESIGN ALFREDO TASCA



MATERIALS:

POWDER COATED STEEL + STAINLESS STEEL

FIXINGS:

PRE DRILLED FOR ANCHORS

DRAWINGS: p. 932



**Put here
your cigarettes!**





SMOKY

DESIGN ALFREDO TASCA



MATERIALS:

POWDER COATED STEEL

FIXINGS:

PRE DRILLED FOR ANCHORS

DRAWINGS: p. 932







SHANGHAI

DESIGN RAFFAELE LAZZARI



MATERIALS:

COATED STAINLESS STEEL + STAINLESS STEEL ACIER

FIXINGS:

FREESTANDING WITH PEDESTALS OR INSTALLATION WITH THREADED

DRAWINGS: p. 935





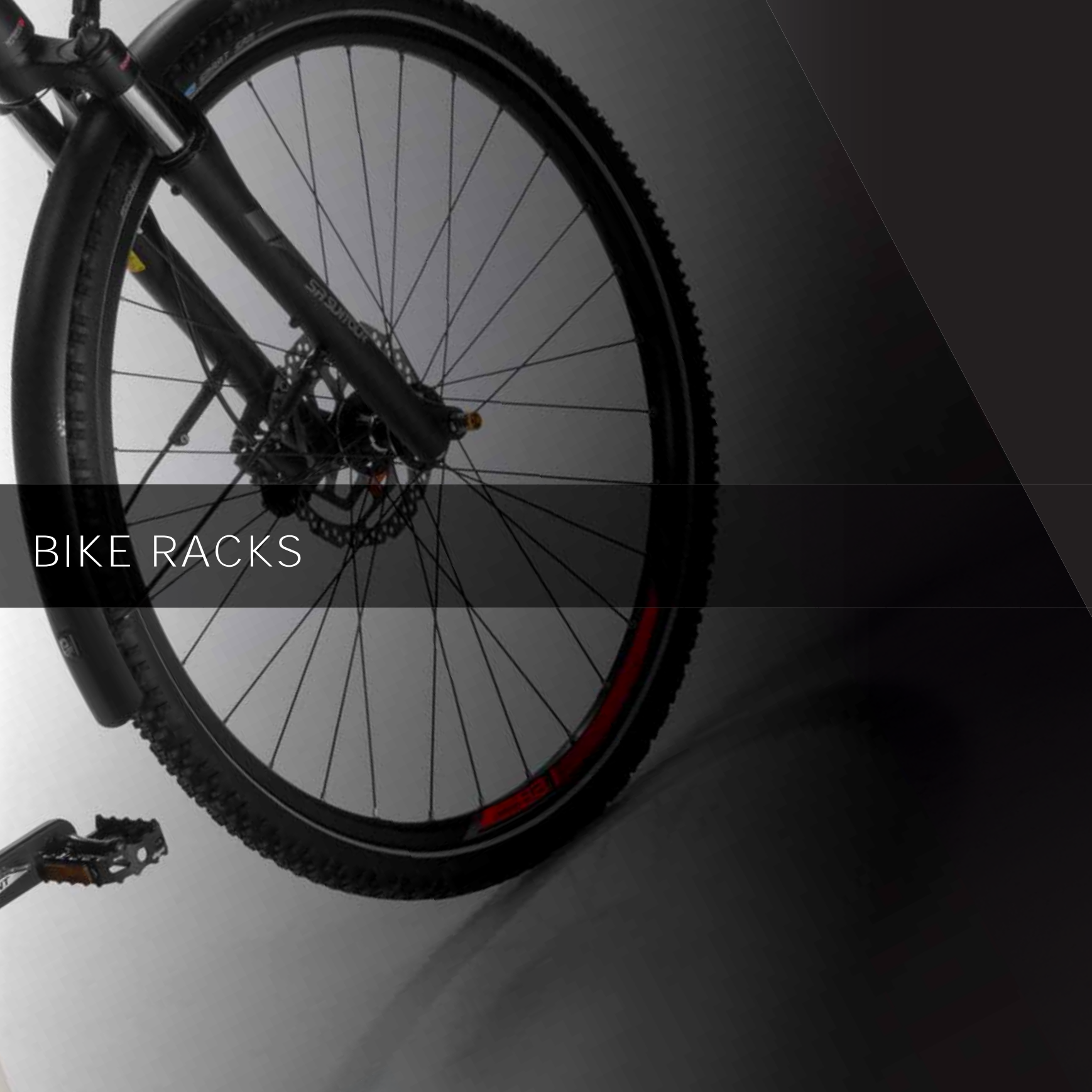

BIKE RACKS





2004, APOLLO BOLLARD / BIKE STAND
DESIGN: STAUBACH & KUCKERTZ

APOLLO

DESIGN STAUBACH & KUCKERTZ



MATERIALS:

POWDER COATED ALUMINUM

FIXINGS:

PREDRILLED FOR ANCHORS OR BELOW GROUND INSTALLATION

DRAWINGS: p. 937





BIKE

METALCO DESIGN



MATERIALS:

POWDER COATED STEEL

FIXINGS:

FREESTANDING WITH PEDESTALS OR INSTALLATION WITH THREADED BARS

DRAWINGS: p. 937







BIKE BOX

DESIGN STAUBACH & KUCKERTZ



MATERIALS:

POWDER COATED STEEL + POWDER COATED ALUMINUM

FIXINGS:

PRE DRILLED FOR ANCHORS

DRAWINGS: p. 937





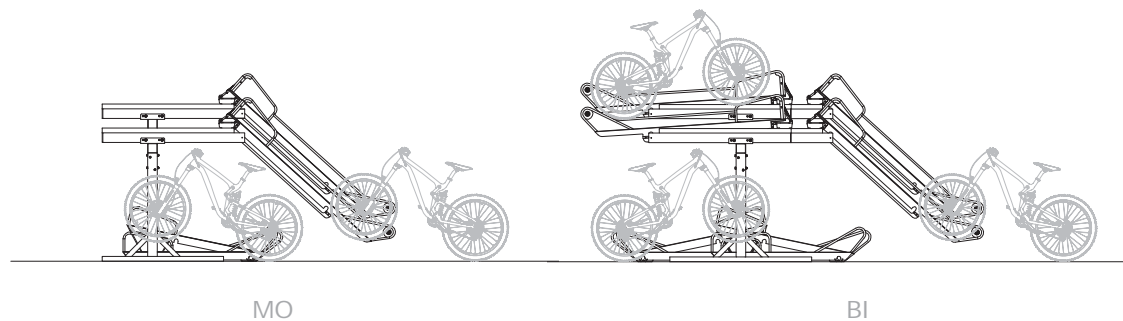

BIPLANO

METALCO DESIGN



MATERIALS:

GALVANISED STEEL

FIXINGS:

PRE DRILLED FOR ANCHORS

DRAWINGS: p. 939







BLAKE

METALCO DESIGN



MATERIALS:

ULTRA HIGH PERFORMANCE CONCRETE

FINISHES:

ALFA

FIXINGS:

BELOW GROUND INSTALLATION

DRAWINGS: p. 938



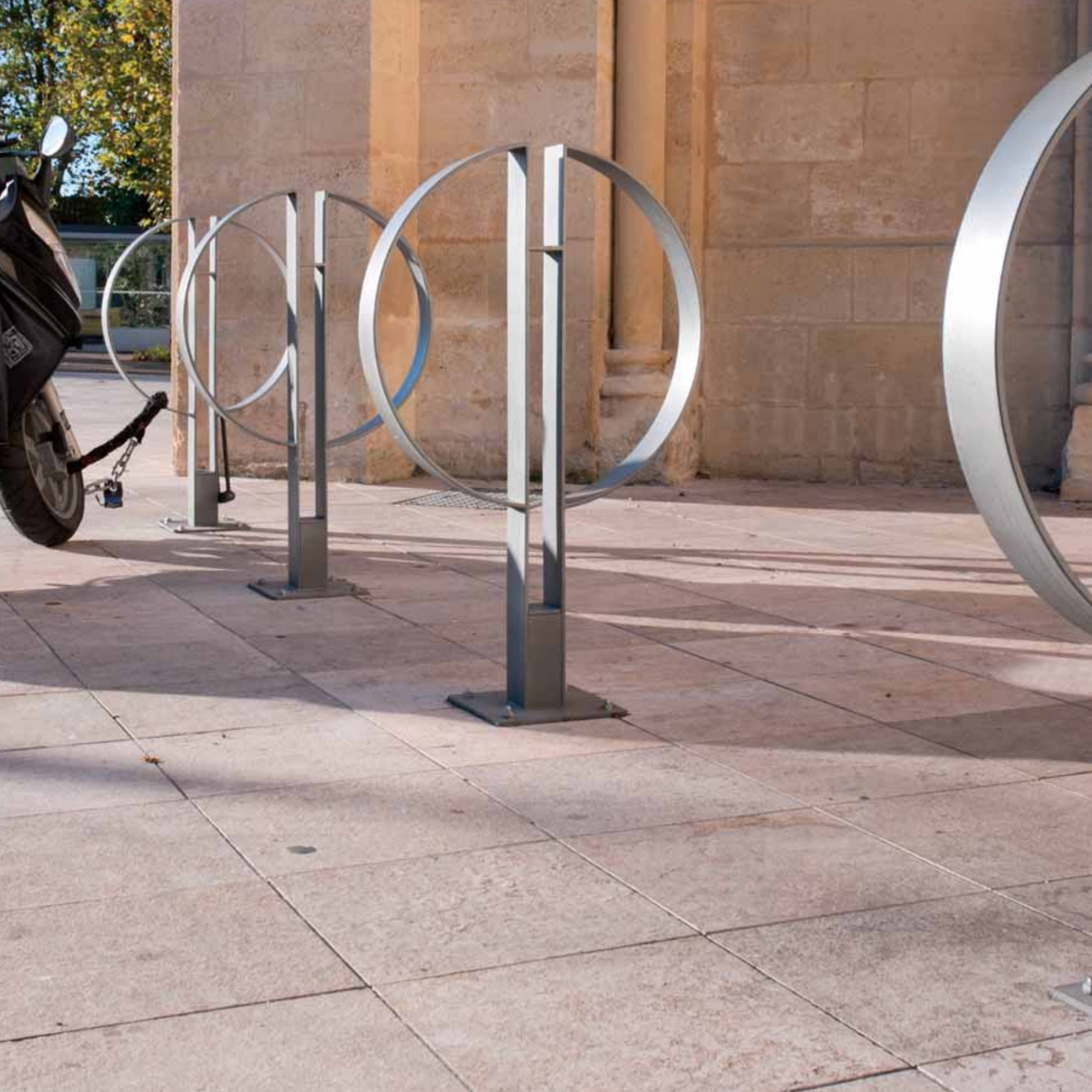



CAFE'

DESIGN SJIT



MATERIALS:

POWDER COATED STEEL OR CORTEN STEEL OR STAINLESS STEEL

FIXINGS:

PRE DRILLED FOR ANCHORS

DRAWINGS: p. 938





CHIAVE

DESIGN RAFFAELE LAZZARI



MATERIALS:

POWDER COATED STEEL OR CORTEN STEEL OR STAINLESS STEEL

FIXINGS:

PREDRILLED FOR ANCHORS OR BELOW GROUND INSTALLATION

DRAWINGS: p. 938



CICLOS

DESIGN ALFREDO TASCA



MATERIALS:

POWDER COATED STEEL OR STAINLESS STEEL

FIXINGS:

PREDRILLED FOR ANCHORS

DRAWINGS: p. 938







CIRCLE

METALCO DESIGN



MATERIALS:

POWDER COATED STEEL OR STAINLESS STEEL

FIXINGS:

PRE DRILLED FOR ANCHORS

DRAWINGS: p. 938





CLOS

DESIGN ALFREDO TASCA



MATERIALS:

POWDER COATED STEEL OR CORTEN STEEL OR STAINLESS STEEL

FIXINGS:

PRE DRILLED FOR ANCHORS

DRAWINGS: p. 938





CRUNA

DESIGN RENATA GIACOMINI



MATERIALS:

POWDER COATED ALUMINUM

FIXINGS:

BELOW GROUND INSTALLATION

DRAWINGS: p. 937





CYCLUS

DESIGN ANTONIO CITTERIO CON TOAN NGUYEN



MATERIALS:

POWDER COATED ALUMINUM

FIXINGS:

PREDRILLED FOR ANCHORS OR BELOW GROUND INSTALLATION

DRAWINGS: p. 937



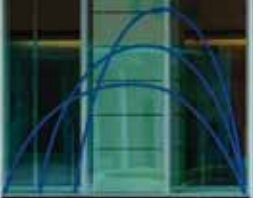



GOMMA

DESIGN SBIKO



MATERIALS:

STEEL COVERED IN RUBBER

FIXINGS:

BELOW GROUND INSTALLATION

DRAWINGS: p. 938



BIG
CHEFS
Studio

OXPAR
OXPAR





GUARDIA

DESIGN ALFREDO TASCA



MATERIALS:

POWDER COATED STEEL OR CORTEN STEEL OR STAINLESS STEEL

FIXINGS:

PREDRILLED FOR ANCHORS OR BELOW GROUND INSTALLATION

DRAWINGS: p. 938

metaco





HEAD

DESIGN ALFREDO TASCA



MATERIALS:

VERNICIATO POWDER COATED ALUMINUM +

POWDER COATED STEEL

FIXINGS:

PREDRILLED FOR ANCHORS OR BELOW GROUND INSTALLATION

DRAWINGS: p. 937



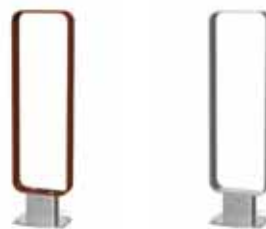

INSIDE

DESIGN STAUBACH & KUCKERTZ



MATERIALS:

POWDER COATED STEEL OR CORTEN STEEL OR STAINLESS STEEL

FIXINGS:

PREDRILLED FOR ANCHORS OR BELOW GROUND INSTALLATION

DRAWINGS: p. 937



120

metaleo

LUCCHETTO

DESIGN RAFFAELE LAZZARI



MATERIALS:

POWDER COATED STEEL OR CORTEN STEEL + STAINLESS STEEL

FIXINGS:

PREDRILLED FOR ANCHORS OR BELOW GROUND

DRAWINGS: p. 938







M



T

MIKADO, TJADO

DESIGN STAUBACH & KUCKERTZ



MATERIALS:

POWDER COATED STEEL

FIXINGS:

PREDRILLED FOR ANCHORS OR BELOW GROUND INSTALLATION

DRAWINGS: p. 937







MOVE

DESIGN SJIT



MATERIALS:

POWDER COATED STEEL OR CORTEN STEEL OR STAINLESS STEEL

FIXINGS:

PRE DRILLED FOR ANCHORS

DRAWINGS: p. 938





OVAL

DESIGN ALFREDO TASCA



MATERIALS:

POWDER COATED STEEL

FIXINGS:

PREDRILLED FOR ANCHORS OR BELOW GROUND INSTALLATION

DRAWINGS: p. 937



PITSTOP

DESIGN STUDIODIECI



MATERIALS:

POWDER COATED STEEL

FIXINGS:

PREDRILLED FOR ANCHORS OR BELOW GROUND INSTALLATION

DRAWINGS: p. 937







RESET

DESIGN ALFREDO TASCA



MATERIALS:

POWDER COATED STEEL OR STAINLESS STEEL

FIXINGS:

PRE DRILLED FOR ANCHORS

DRAWINGS: p. 938





RUBB

DESIGN ALFREDO TASCA



MATERIALS:

STEEL COVERED IN RUBBER

FIXINGS:

BELOW GROUND INSTALLATION

DRAWINGS: p. 938





Bullet

Aurore



Aurore



SILVER

DESIGN MATTIA LI PONI



MATERIALS:

POWDER COATED STEEL OR STAINLESS STEEL

FIXINGS:

PRE DRILLED FOR ANCHORS

DRAWINGS: p. 937





SMERALDO

DESIGN ALFREDO TASCA



MATERIALS:

RECONSTITUTED STONES + POWDER COATED STEEL OR STAINLESS STEEL

FINISHES:

SANDBLASTED

FIXINGS:

FREE STANDING

DRAWINGS: p. 938

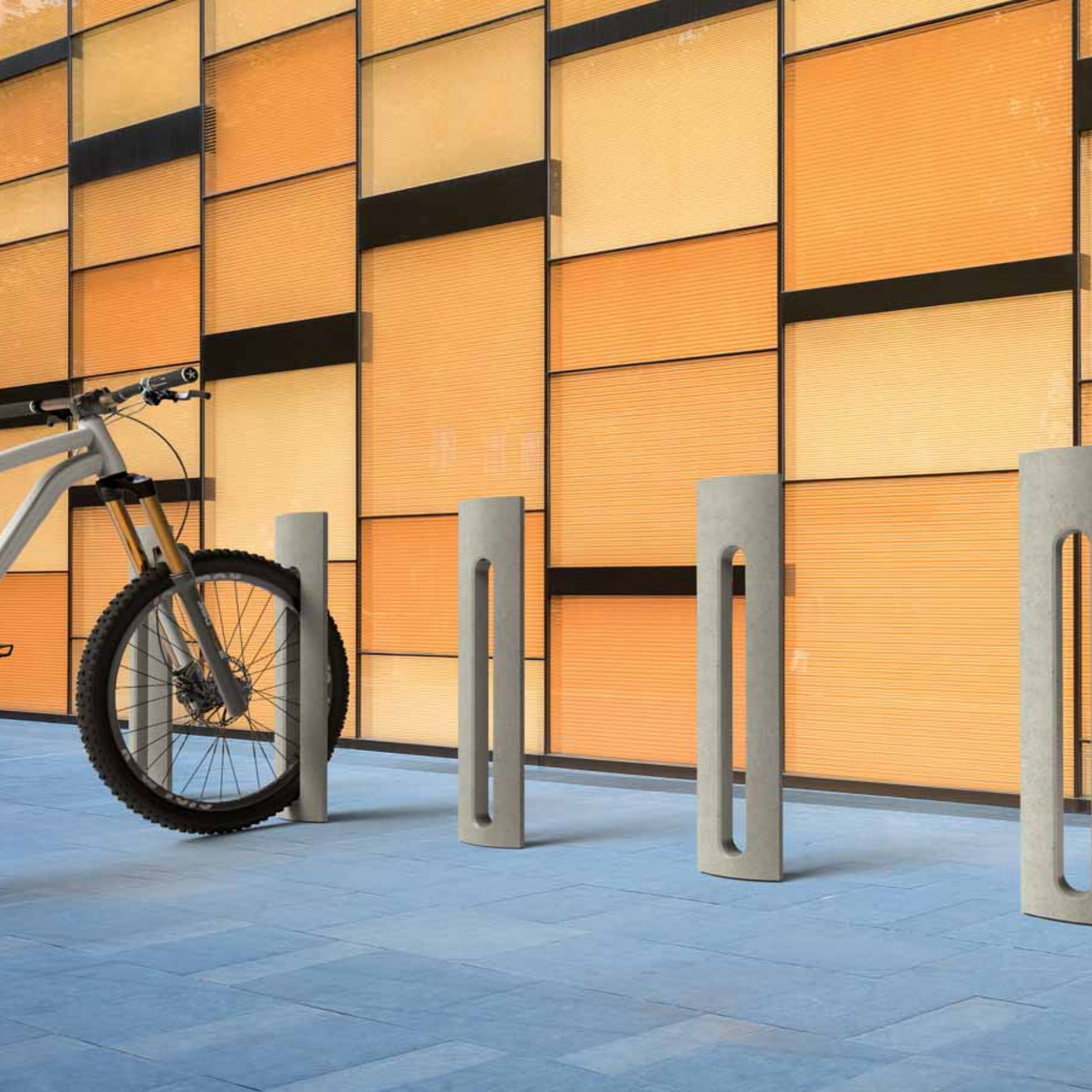



SPRING P

DESIGN RAFFAELE LAZZARI



MATERIALS:

ULTRA HIGH PERFORMANCE CONCRETE

FINISHES:

ALFA

FIXINGS:

INSTALLATION WITH THREADED BARS

DRAWINGS: p. 938





SPYRA

DESIGN ALFREDO TASCA



MATERIALS:

POWDER COATED STEEL OR STAINLESS STEEL

FIXINGS:

INSTALLATION WITH THREADED BARS

DRAWINGS: p. 937



SPYRA

DESIGN ALFREDO TASCA





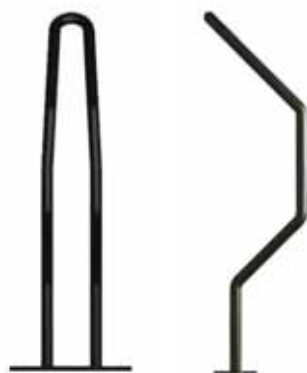

TYPE

METALCO DESIGN



MATERIALS:

POWDER COATED STEEL

FIXINGS:

PREDRILLED FOR ANCHORS OR BELOW GROUND INSTALLATION

DRAWINGS: p. 938





BOLLARDS &





BARRIERS



CARPI

DESIGN TONI FOLLINA



MATERIALS:

POWDER COATED ALUMINUM

FIXINGS:

PREDRILLED FOR ANCHORS OR BELOW GROUND INSTALLATION

DRAWINGS: p. 940





MAGIC

DESIGN ALFREDO TASCA



MATERIALS:

POWDER COATED STEEL + STAINLESS STEEL

FIXINGS:

BELOW GROUND INSTALLATION

DRAWINGS: p. 942





CORALLO

DESIGN ALFREDO TASCA



MATERIALS:

RECONSTITUTED STONES

FINISHES:

SMOOTH SEAT AND SANDBLASTED SIDES

FIXINGS:

FREE STANDING

DRAWINGS: p. 941



CORALLO

DESIGN ALFREDO TASCA







CROSS

METALCO DESIGN



MATERIALS:

POWDER COATED ALUMINUM + POWDER COATED STEEL + STAINLESS STEEL

FIXINGS:

PREDRILLED FOR ANCHORS OR BELOW GROUND INSTALLATION

DRAWINGS: p. 942





CUBE

DESIGN ALFREDO TASCA



MATERIALS:

POWDER COATED STEEL OR CORTEN STEEL OR STAINLESS STEEL

FIXINGS:

PRE DRILLED FOR ANCHORS

DRAWINGS: p. 941



CUBE

DESIGN ALFREDO TASCA



COURS DE L'ÉPÉE, LYON, FRANCE
© PROJECT AND PHOTO: ATELIER DU BOCAL, ARMELLE BARRIÈRE, LYON, FRANCE





DELINEA

DESIGN SJIT



MATERIALS:

POWDER COATED STEEL OR CORTEN STEEL + STAINLESS STEEL

FIXINGS:

PREDRILLED FOR ANCHORS OR BELOW GROUND INSTALLATION

DRAWINGS: p. 943





DIFFUSION NEWS

METALCO DESIGN



MATERIALS:

POWDER COATED STEEL OR OXIDIZED STEEL OR STAINLESS STEEL

FIXINGS:

PREDRILLED FOR ANCHORS OR BELOW GROUND INSTALLATION

DRAWINGS: p. 940



DIX

METALCO DESIGN



SST

MATERIALS:

STAINLESS STEEL

FIXINGS:

PREDRILLED FOR ANCHORS OR BELOW GROUND INSTALLATION

DRAWINGS: p. 940





EXPLOSION

DESIGN RAFFAELE LAZZARI



MATERIALS:

POWDER COATED STEEL OR CORTEN STEEL OR STAINLESS STEEL

FIXINGS:

PREDRILLED FOR ANCHORS OR BELOW GROUND INSTALLATION

DRAWINGS: p. 940







GALA

DESIGN AUREL DESIGN URBAIN



MATERIALS:

CORTEN POWDER COATED STEEL OR CORTEN STEEL

FIXINGS:

BELOW GROUND INSTALLATION

DRAWINGS: p. 943





GENESIS

DESIGN ALFREDO TASCA



MATERIALS:

POWDER COATED STEEL OR OXIDIZED STEEL + STAINLESS STEEL

FIXINGS:

PREDRILLED FOR ANCHORS OR BELOW GROUND INSTALLATION

DRAWINGS: p. 941





GITTER

DESIGN STAUBACH & KUCKERTZ



MATERIALS:

POWDER COATED STEEL OR CORTEN STEEL + STAINLESS STEEL

FIXINGS:

BELOW GROUND INSTALLATION

DRAWINGS: p. 943





HARLEM

METALCO DESIGN



MATERIALS:

POWDER COATED ALUMINUM + POWDER COATED STEEL

FIXINGS:

PREDRILLED FOR ANCHORS OR BELOW GROUND INSTALLATION

DRAWINGS: p. 942



HESPERIA

DESIGN PIERO MEZZAPELLE



MATERIALS:

POWDER COATED STEEL OR CORTEN STEEL

FIXINGS:

PREDRILLED FOR ANCHORS OR BELOW GROUND INSTALLATION

DRAWINGS: p. 941





ICS

DESIGN SJIT



MATERIALS:

CORTEN STEEL + STAINLESS STEEL

FIXINGS:

BELOW GROUND INSTALLATION

DRAWINGS: p. 942





ISTRA

DESIGN AUREL DESIGN URBAIN



MATERIALS:

POWDER COATED ALUMINUM

FIXINGS:

PREDRILLED FOR ANCHORS OR BELOW GROUND INSTALLATION

DRAWINGS: p. 940

LOUIS VUITTON





MIZAR D

DESIGN ALFREDO TASCA

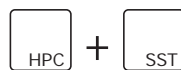

MATERIALS:

HIGH PERFORMANCE CONCRETE + STAINLESS STEEL

FINISHES:

VELLUTO

FIXINGS:

FREE STANDING

DRAWINGS: p. 914

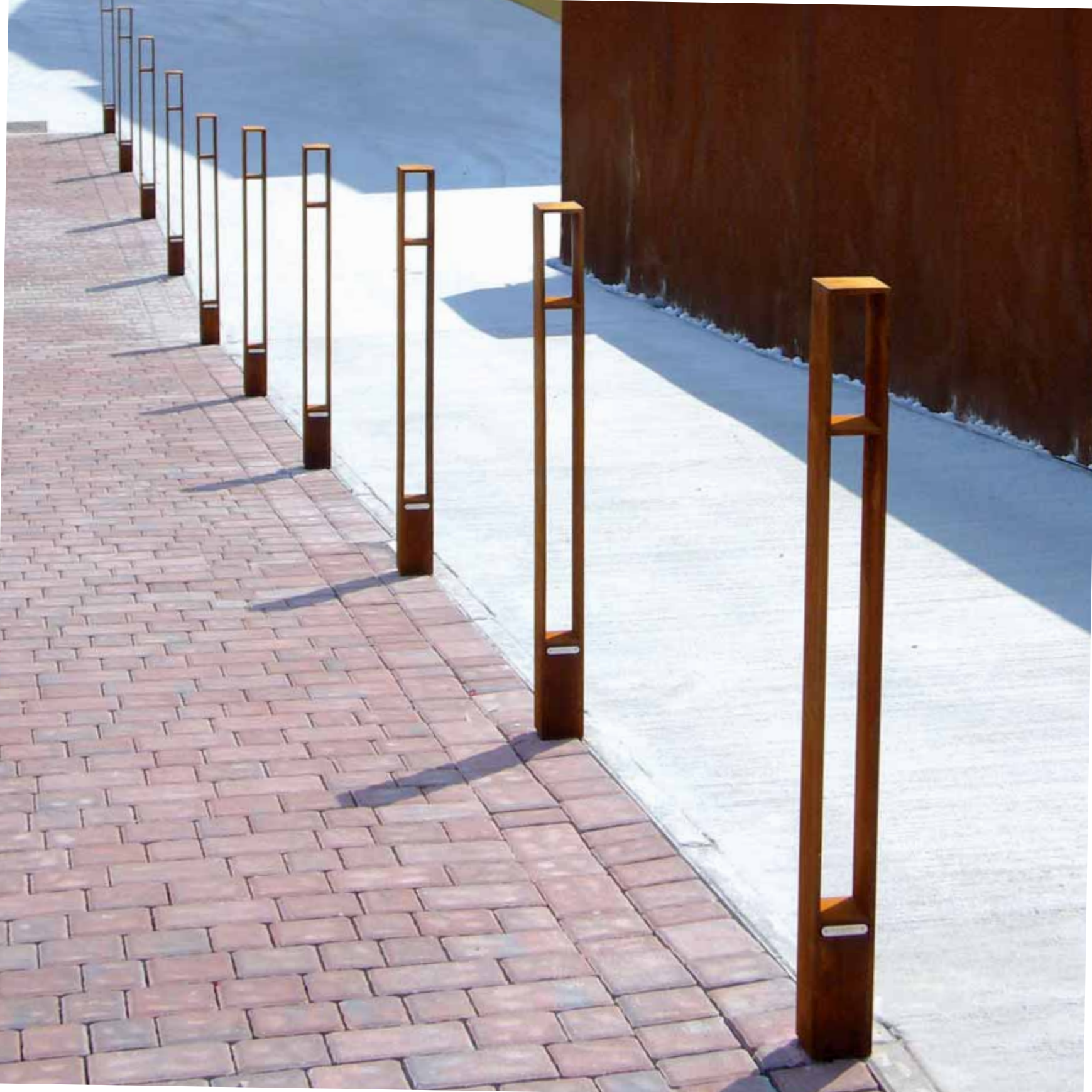



MOKA

DESIGN SJIT



MATERIALS:

POWDER COATED STEEL OR CORTEN STEEL OR STAINLESS STEEL

FIXINGS:

PREDRILLED FOR ANCHORS OR BELOW GROUND INSTALLATION

DRAWINGS: p. 940





NEA

METALCO DESIGN



MATERIALS:

POWDER COATED ALUMINUM + POWDER COATED STEEL

FIXINGS:

PREDRILLED FOR ANCHORS OR BELOW GROUND INSTALLATION

DRAWINGS: p. 942





ONORIUS

DESIGN AUREL DESIGN URBAIN



MATERIALS:

POWDER COATED ALUMINUM

FIXINGS:

BELOW GROUND INSTALLATION

DRAWINGS: p. 940





2009, ADI DESIGN INDEX®
AND "COMPASSO D'ORO"



2011, XXII EDITION OF
PREMIO COMPASSO D'ORO:
PALUS BOLLARD (DESIGN:
ANTONIO CITTERIO WITH
TOAN NGUYEN)

PALUS

DESIGN ANTONIO CITTERIO CON TOAN NGUYEN



MATERIALS:

POWDER COATED ALUMINUM

FIXINGS:

PREDRILLED FOR ANCHORS OR BELOW GROUND INSTALLATION

DRAWINGS: p. 942







PENCIL

DESIGN STAUBACH & KUCKERTZ



MATERIALS:

POWDER COATED STEEL

FIXINGS:

BELOW GROUND INSTALLATION

DRAWINGS: p. 942





PIREO

METALCO DESIGN



MATERIALS:

POWDER COATED ALUMINUM + POWDER COATED STEEL

FIXINGS:

PREDRILLED FOR ANCHORS OR BELOW GROUND INSTALLATION

DRAWINGS: p. 940





QUICK

METALCO DESIGN



MATERIALS:

POWDER COATED STEEL

FIXINGS:

PREDRILLED FOR ANCHORS OR BELOW GROUND INSTALLATION

DRAWINGS: p. 940





ROUTE

DESIGN ALAIN MARGUERIT



MATERIALS:

CORTEN POWDER COATED STEEL OR CORTEN STEEL

FIXINGS:

PREDRILLED FOR ANCHORS OR BELOW GROUND INSTALLATION

DRAWINGS: p. 941



SIGARO

DESIGN ALFREDO TASCA



MATERIALS:

POWDER COATED ALUMINUM

FIXINGS:

PREDRILLED FOR ANCHORS OR BELOW GROUND INSTALLATION

DRAWINGS: p. 940



cafe venice

TATTOO
PERCING

PIZZERIA

ATM



SPRING D

DESIGN RAFFAELE LAZZARI



MATERIALS: ULTRA HIGH PERFORMANCE CONCRETE

FINISHES:

ALFA

FIXINGS:

INSTALLATION WITH THREADED BARS

DRAWINGS: p. 941







TRANSEO

DESIGN ANTONIO CITTERIO CON TOAN NGUYEN



MATERIALS:

POWDER COATED ALUMINUM

FIXINGS:

PREDRILLED FOR ANCHORS OR BELOW GROUND INSTALLATION

DRAWINGS: p. 942





V-FORM

DESIGN STAUBACH & KUCKERTZ



MATERIALS:

POWDER COATED STEEL OR CORTEN STEEL + STAINLESS STEEL

FIXINGS:

BELOW GROUND INSTALLATION

DRAWINGS: p. 943

OSPEDALE DI TREVISO

AZIENDA
ULSS 9
TREVISO





VERSO P, X, 490, 240

DESIGN ALFREDO TASCA



MATERIALS:

POWDER COATED STEEL OR CORTEN STEEL + STAINLESS STEEL

FIXINGS:

PREDRILLED FOR ANCHORS OR BELOW GROUND INSTALLATION

DRAWINGS: p. 941





VISION

DESIGN SJIT



MATERIALS:

POWDER COATED STEEL OR CORTEN STEEL OR STAINLESS STEEL

FIXINGS:

PREDRILLED FOR ANCHORS OR BELOW GROUND INSTALLATION

DRAWINGS: p. 941

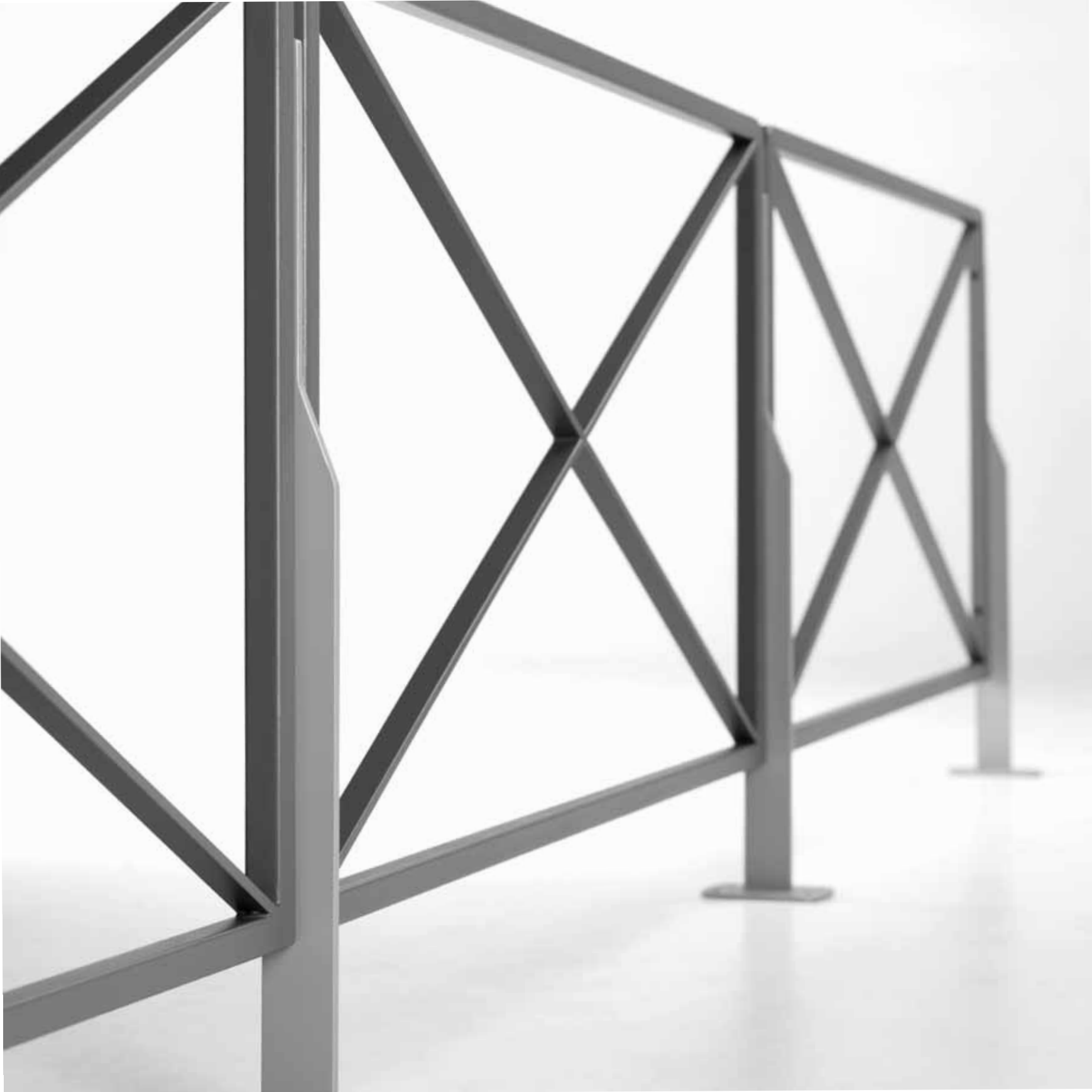



VOILÀ

DESIGN ALFREDO TASCA



MATERIALS:

POWDER COATED STEEL

FIXINGS:

PREDRILLED FOR ANCHORS OR BELOW GROUND INSTALLATION

DRAWINGS: p. 942



LIDO PATRIZIALE ASCONA



WORD

DESIGN SJIT



MATERIALS:

POWDER COATED STEEL OR CORTEN STEEL OR STAINLESS STEEL

FIXINGS:

PREDRILLED FOR ANCHORS OR BELOW GROUND INSTALLATION

DRAWINGS: p. 943



WORD

DESIGN SJIT







ø 500 mm

ø 700 mm

ZAFFIRO

DESIGN ALFREDO TASCA



MATERIALS:

RECONSTITUTED STONES

FINISHES:

MIXED SMOOTH - SANDBLASTED

FIXINGS:

INSTALLATION WITH THREADED BARS

DRAWINGS: p. 941





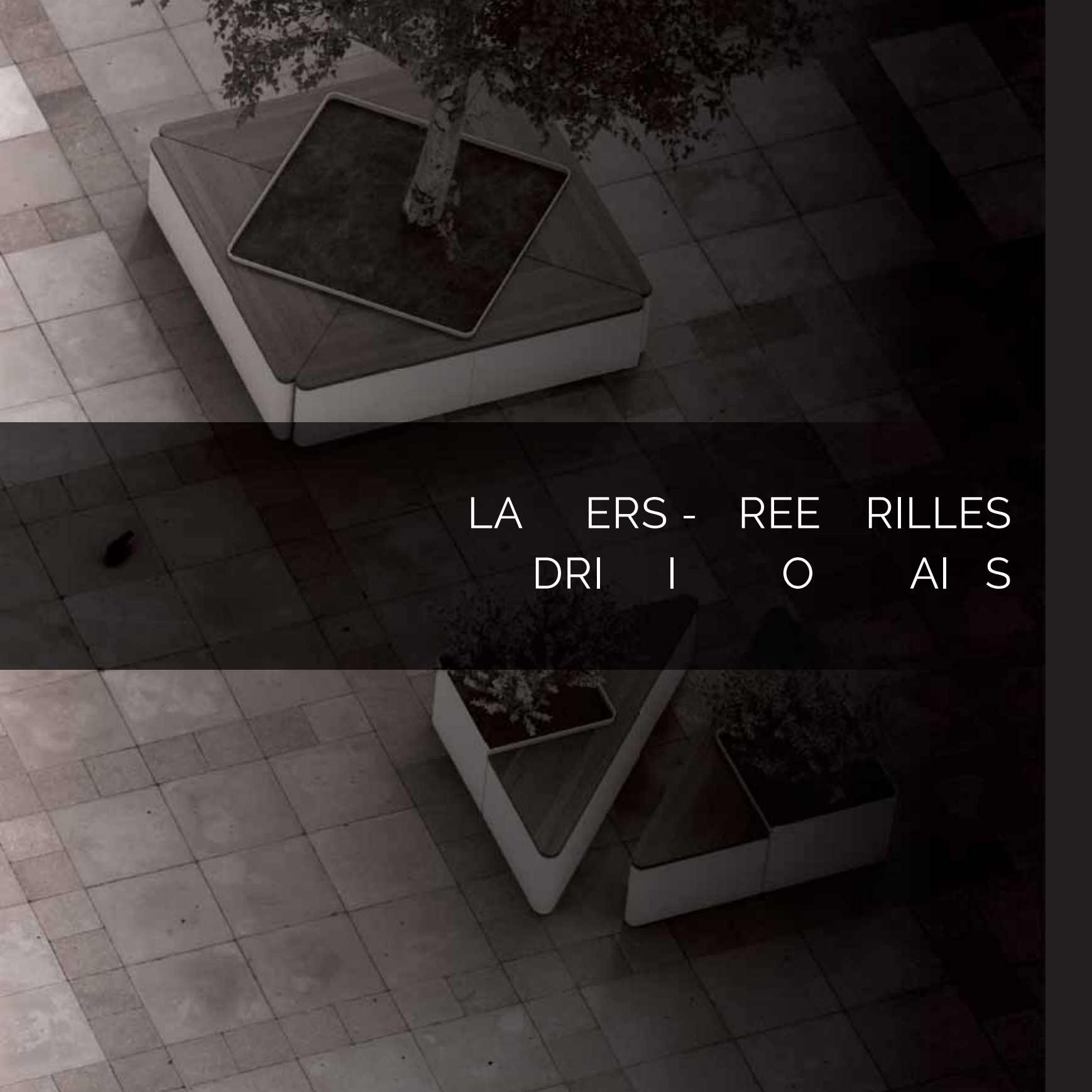

LA ERS - REE RILLES
DRI I O AI S





ALFA, BETA, GAMMA

DESIGN RAFFAELE LAZZARI



MATERIALS:

POWDER COATED STEEL OR CORTEN STEEL OR STAINLESS STEEL

FIXINGS:

FREE STANDING

DRAWINGS: p. 944





w .meta
439 0423







ARBORIS

DESIGN ANTONIO CITTERIO CON TOAN NGUYEN



MATERIALS:

POWDER COATED STEEL

FIXINGS:

BELOW GROUND INSTALLATION + FREESTANDING

DRAWINGS: p. 947



ASTER

METALCO DESIGN



MATERIALS:

POWDER COATED STEEL OR CORTEN STEEL OR STAINLESS STEEL

FIXINGS:

FREE STANDING

DRAWINGS: p. 944







BALZAC

PAMIO DESIGN

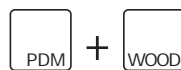

MATERIALS:

RECONSTITUTED STONES + EXOTIC WOOD

FINISHES:

POLISHED OR SANDBLASTED

FIXINGS:

FREESTANDING OR INSTALLATION WITH THREADED BAR

DRAWINGS: p. 946













BALZAC

PAMIO DESIGN





BAMBU'

METALCO DESIGN



MATERIALS:

POWDER COATED STEEL OR CORTEN STEEL OR STAINLESS STEEL

FIXINGS:

FREE STANDING

DRAWINGS: p. 944

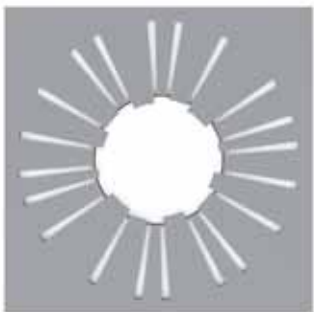

SUNNY

DESIGN RAFFAELE LAZZARI



MATERIALS:

POWDER COATED STEEL OR CORTEN STEEL OR STAINLESS STEEL

FIXINGS:

BELOW GROUND INSTALLATION + FREESTANDING

DRAWINGS: p. 949





CALYX

DESIGN MASSIMO TASCA



MATERIALS:

POWDER COATED STEEL OR CORTEN STEEL OR STAINLESS STEEL

FIXINGS:

BELOW GROUND INSTALLATION + FREESTANDING

DRAWINGS: p. 948





DAHLIA

METALCO DESIGN



MATERIALS:

POWDER COATED STEEL OR CORTEN STEEL OR STAINLESS STEEL

FIXINGS:

FREE STANDING

DRAWINGS: p. 944



DAHLIA

METALCO DESIGN







ECCENTRICA

DESIGN ALFREDO TASCA



MATERIALS:

POWDER COATED STEEL OR CORTEN STEEL OR STAINLESS STEEL

FIXINGS:

FREE STANDING

DRAWINGS: p. 948







ELLI

DESIGN RAFFAELE LAZZARI



MATERIALS:

RECONSTITUTED STONES

FINISHES:

SANDBLASTED

FIXINGS:

FREE STANDING

DRAWINGS: p. 945











FLÒ

DESIGN ALESSANDRO LENARDA



MATERIALS:

POWDER COATED STEEL + OKUME WOOD

FIXINGS:

FREE STANDING

DRAWINGS: p. 945



FLÒ

DESIGN ALESSANDRO LENARDA









Henry

L

Orange

Orange

Orange

Orange

Orange

Orange

Orange

Orange

Orange

Orange

Orange

Orange

Orange

Orange

Orange

Orange

Orange



FLORA, LITTERA, STELO

DESIGN RAFFAELE LAZZARI



MATERIALS:

POWDER COATED STEEL OR CORTEN STEEL OR STAINLESS STEEL

FIXINGS:

BELOW GROUND INSTALLATION + FREESTANDING

DRAWINGS: p. 949



FLORES

DESIGN ANTONIO CITTERIO CON TOAN NGUYEN



MATERIALS:

POWDER COATED ALUMINUM + POWDER COATED STEEL

FIXINGS:

FREE STANDING

DRAWINGS: p. 945





FC

FE

FR

FUENTE C, E, R

DESIGN RAFFAELE LAZZARI



MATERIALS:

POWDER COATED STEEL OR CORTEN STEEL OR STAINLESS STEEL

FIXINGS:

BELOW GROUND INSTALLATION

DRAWINGS: p. 943





FUENTE C, E, R

DESIGN RAFFAELE LAZZARI







HELMUT

DESIGN STAUBACH & KUCKERTZ



MATERIALS:

POWDER COATED STEEL

FIXINGS:

FREE STANDING WITH PEDESTALS (INDOOR ONLY)

DRAWINGS: p. 947





LAND

DESIGN ALFREDO TASCA



MATERIALS:

POWDER COATED STEEL OR CORTEN STEEL OR STAINLESS STEEL

FIXINGS:

BELOW GROUND INSTALLATION + FREESTANDING

DRAWINGS: p. 949



LOUNGE

METALCO DESIGN



MATERIALS:

POWDER COATED STEEL OR CORTEN STEEL OR STAINLESS STEEL

FIXINGS:

FREE STANDING

DRAWINGS: p. 944







OBRA C, Q, R

AUREL DESIGN URBAIN



MATERIALS:

POWDER COATED STEEL OR CORTEN STEEL OR STAINLESS STEEL

FIXINGS:

BELOW GROUND INSTALLATION + FREESTANDING

DRAWINGS: p. 947



PERLA C, Q

DESIGN RAFFAELE LAZZARI



MATERIALS:

POWDER COATED STEEL OR CORTEN STEEL OR STAINLESS STEEL

FIXINGS:

BELOW GROUND INSTALLATION + FREESTANDING

DRAWINGS: p. 947







ONICE

DESIGN STAUBACH & KUCKERTZ

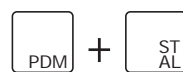

MATERIALS:

RECONSTITUTED STONES + POWDER COATED STEEL

FINISHES:

SANDBLASTED

FIXINGS:

FREE STANDING

DRAWINGS: p. 945





ø 855 | 370



ø 946 | 665

PITOCCA

DESIGN SJIT



MATERIALS:

POWDER COATED STEEL OR CORTEN STEEL OR STAINLESS STEEL

FIXINGS:

FREE STANDING

DRAWINGS: p. 945





PITOCCA

DESIGN SJIT







SPRING F

DESIGN RAFFAELE LAZZARI



MATERIALS:

ULTRA HIGH PERFORMANCE CONCRETE + STAINLESS STEEL

FINISHES:

ALFA

FIXINGS:

BELOW GROUND INSTALLATION

DRAWINGS: p. 943



TWISTER

DESIGN MATTIA LI POMI



MATERIALS:

POWDER COATED STEEL OR CORTEN STEEL OR STAINLESS STEEL

FIXINGS:

BELOW GROUND INSTALLATION + FREESTANDING

DRAWINGS: p. 949





3XL



XXL



XL



SIZE

DESIGN MASSIMO TASCA



MATERIALS:

CORTEN STEEL

FIXINGS:

FREE STANDING

DRAWINGS: p. 946









TRIANGLE

DESIGN STAUBACH & KUCKERTZ



MATERIALS:

POWDER COATED STEEL + OKOUME PLYWOOD

FIXINGS:

FREE STANDING

DRAWINGS: p. 946



EXIT

HILFIGER

0

Wohnen	
Food Plaza	10
Restaurants	11
Art	12
Services	13
Parkhaus	14
Shopping	15
Public Area	16

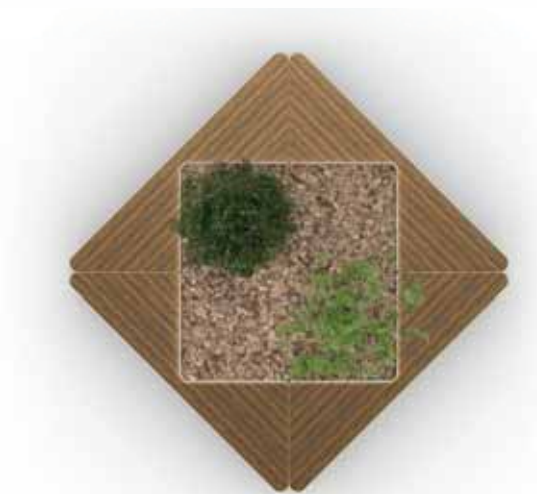

DE GU STI BUS

Tour enogastronomico
nella città di Cuneo

Corso Nizza - Piazza Galimberti
29-30 Aprile e 1 Maggio
CUNEO 2016

7ª EDIZIONE



DISPLAY STANDS AND INFORMATION POSTS





ALTUS, LATUS

DESIGN ANTONIO CITTERIO CON TOAN NGUYEN



MATERIALS:

POWDER COATED ALUMINUM + POWDER COATED STEEL

FIXINGS:

BELOW GROUND INSTALLATION

DRAWINGS: p. 951



250
ANNI
ACCADEMICO



Città di
Castelfranco
Veneto

Otto eventi
per festeggiare
i 250 anni
del teatro
di Castelfranco
Veneto

27 settembre
9 novembre 2008

Programma



ANNUNCI

DESIGN PAMIO DESIGN



MATERIALS:

POWDER COATED STEEL OR CORTEN STEEL + STAINLESS STEEL

FIXINGS:

PRE DRILLED FOR ANCHORS

DRAWINGS: p. 949



Parochial





ASPEN

METALCO DESIGN



MATERIALS:

POWDER COATED STEEL OR CORTEN STEEL + POWDER COATED STEEL

FIXINGS:

BELOW GROUND INSTALLATION

DRAWINGS: p. 949





Il territorio di Sanseverino è stato abitato fin dall'epoca preistorica. Nel 1871, con la legge n. 2233, il Comune di Sanseverino è stato istituito con l'annessione di alcuni comuni limitrofi. Il territorio è caratterizzato da una morfologia prevalentemente collinare, con altitudini che variano tra i 150 e i 300 metri s.l.m. Il clima è temperato, con precipitazioni annue di circa 1000 mm. L'economia è basata principalmente sull'agricoltura e sull'artigianato. Il Comune è dotato di servizi essenziali, tra cui scuole, asili nido, uffici pubblici e servizi sociali. La popolazione è di circa 1500 abitanti, con una densità di popolazione di circa 150 abitanti/km². Il Comune è parte integrante del territorio della Provincia di Arezzo.



ATHOS

DESIGN ALFREDO TASCA



MATERIALS: POWDER COATED STEEL OR CORTEN STEEL + STAINLESS STEEL

FIXINGS:

PRE DRILLED FOR ANCHORS

DRAWINGS: p. 949





BACH

METALCO DESIGN

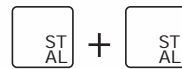

MATERIALS: POWDER COATED ALUMINUM + POWDER COATED STEEL

FIXINGS:

BELOW GROUND INSTALLATION

DRAWINGS: p. 950



Parco Naturale



CHAMONIX

METALCO DESIGN



MATERIALS:

POWDER COATED STEEL OR CORTEN STEEL + POWDER COATED STEEL

FIXINGS:

BELOW GROUND INSTALLATION

DRAWINGS: p. 949



centro



Camping Cerbaro





DUPLUS, PARVUS, SINGULA

DESIGN ANTONIO CITTERIO CON TOAN NGUYEN



MATERIALS:

POWDER COATED ALUMINUM + POWDER COATED STEEL

FIXINGS:

BELOW GROUND INSTALLATION

DRAWINGS: p. 950







EXPO

DESIGN ALFREDO TASCA + RAFFAELE LAZZARI



MATERIALS:

HIGH PERFORMANCE CONCRETE

FINISHES:

MIXED POLISHED - VELLUTO

FIXINGS:

BELOW GROUND INSTALLATION

DRAWINGS: p. 951







TEATRO COMUNALE DI CARPI

Regione Emilia 2008 - 2009

DANZA

PASCAL BLOUET
DANCE THEATRE
NEW YORK
Serata Ravel - Stravinskij
Lo spazio - Una - L'Usual di Pagan
con il gruppo Pascal Blouet

COMPAGNIA ARTYMIS DANZA
MONICA CASAROLI
Latino America - Trilogia
L'arte di un'artista Latina
L'arte di un'artista Latina
L'arte di un'artista Latina

BALLETTO DEL TEATRO DELL'OPERA NAZIONALE DI ROMANIA
Cecilia Costescu
Serata - Una - L'Usual di Pagan
con il gruppo Cecilia Costescu

NUOVO BALLET ESPAÑO
Balletto Nazionale di Spagna
Sagra Flamenca



MOMIX
Balletto di danza contemporanea
con il gruppo MOMIX

UnCredit Banca



ICARO

DESIGN SJIT



MATERIALS:

POWDER COATED STEEL OR CORTEN STEEL OR STAINLESS STEEL +
STAINLESS STEEL

FIXINGS:

PRE DRILLED FOR ANCHORS

DRAWINGS: p. 949

LANZAROTE

DESIGN ALFREDO TASCA

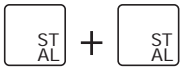

MATERIALS:

POWDER COATED ALUMINUM + POWDER COATED STEEL

FIXINGS:

BELOW GROUND INSTALLATION

DRAWINGS: p. 951





LEGGIO

DESIGN STUDIO KUADRA



MATERIALS:

POWDER COATED STEEL + ALUMINIUM COMPOSITE PANEL

FIXINGS:

PRE DRILLED FOR ANCHORS

DRAWINGS: p. 950



BRIS



OMNIEXPO

DESIGN STUDIO COMOLLI E MAFFÈ



MATERIALS:

CORTEN POWDER COATED STEEL OR CORTEN STEEL STEEL

FIXINGS:

PRE DRILLED FOR ANCHORS

DRAWINGS: p. 949



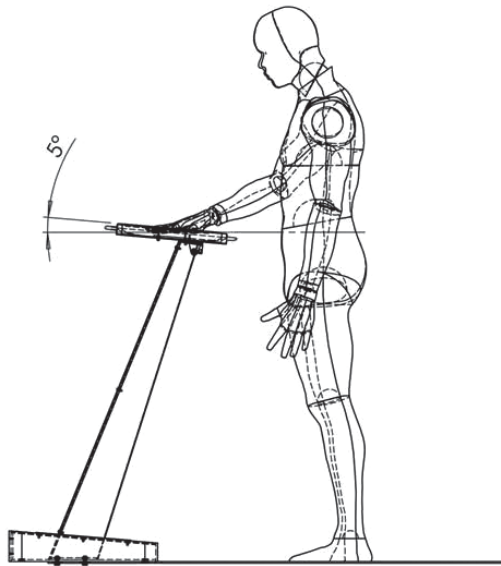

PEGASUS

DESIGN DAVIDE LORENZON



MATERIALS:

POWDER COATED STEEL

FIXINGS:

FREE STANDING (INDOOR ONLY)

DRAWINGS: p. 952

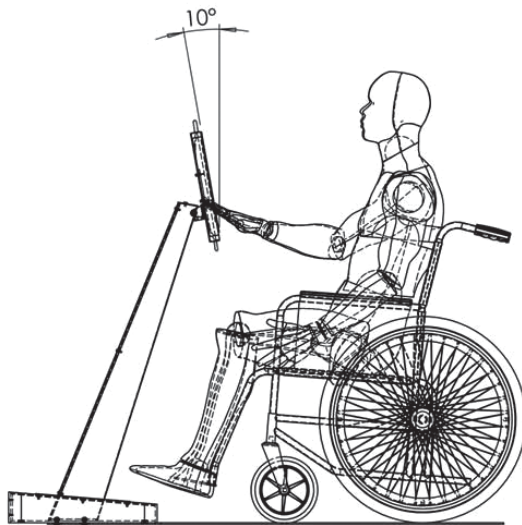



PEGASUS

DESIGN DAVIDE LORENZON

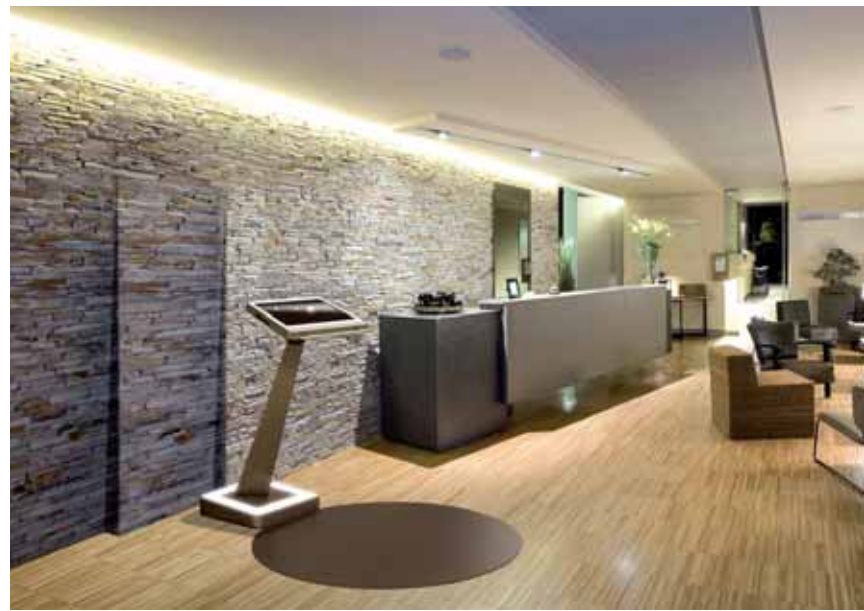



SENNA

METALCO DESIGN



MATERIALS:

POWDER COATED STEEL OR CORTEN STEEL + ALUMINIUM COMPOSITE PANEL

FIXINGS:

PRE DRILLED FOR ANCHORS

DRAWINGS: p. 952



FONDAZIONE
FRANCESCA RAVA

in collaborazione con
TEATRO
DELLE MUSE

con il patrocinio di
COMUNE DI ANCONA
PROVINCIA DI ANCONA
REGIONE MARCHE

TEATRO DELLE MUSE - ANCONA
13 maggio 2008, ore 21

Andrea Bocelli

Giuseppe Tomassini Direttore
Orchestra Filarmonica Marchigiana Direttore Riccardo Muti
Paola Seppierotti Soprano

Concerto per i bambini di N.P.H. Haiti

Spettacolo straordinario dedicato alla
Fondazione Francesca Rava - N.P.H. Italia Onlus

Il ricavato della serata sarà devoluto alla Casa dei Piccoli Angeli, Centro di riabilitazione N.P.H. per bambini con handicap fisico e psichici nel paese quarto mondo di Haiti.

PER INFORMAZIONI:
Fondazione Francesca Rava - N.P.H. Italia Onlus
Tel: 051/2211111 - info@fondazione.org - www.fondazione.org

PER IL BIGLIETTO:
Via dell'Industria, 10 - Ancona Tel: 051/2211111 - Tel: 051/2211111
info@fondazione.org - www.fondazione.org

in sponsor:

Banca Marche
Emilapost
MAGAZINE

6
Società
S.p.A.

SEMPRE
INNOVANDO
SOLUZIONI
PER VOI





TARGA

DESIGN BETANCOURTDESIGN



MATERIALS:

POWDER COATED STEEL OR CORTEN STEEL + GALVANISED STEEL

FIXINGS:

PREDRILLED FOR ANCHORS OR BELOW GROUND INSTALLATION

DRAWINGS: p. 949







TED

DESIGN MATTIA LI POMI



MATERIALS:

POWDER COATED STEEL

FIXINGS:

PRE DRILLED FOR ANCHORS

DRAWINGS: p. 952

Rathaus

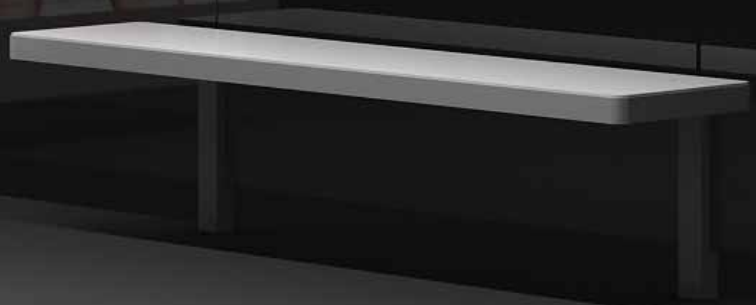
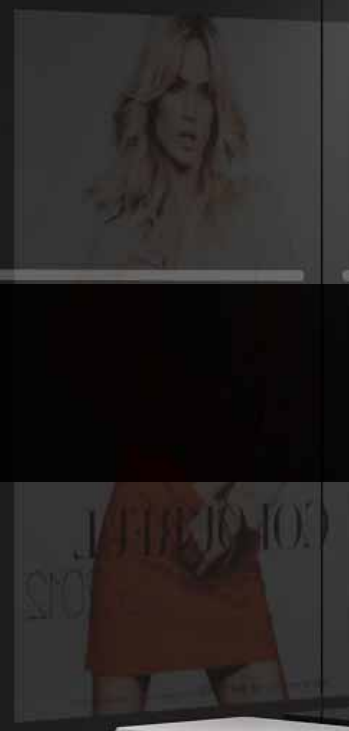

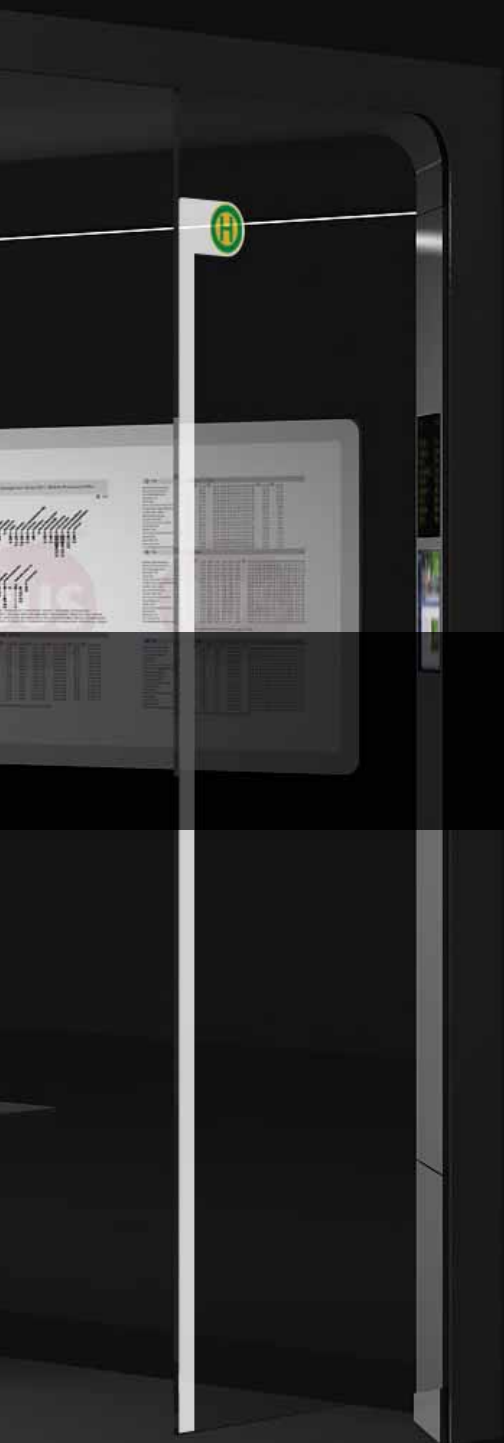

S EL ERS O ERA ES





ARTS

DESIGN ALFREDO TASCA



MATERIALS:

POWDER COATED ALUMINUM + POWDER COATED STEEL + STAINLESS STEEL

FIXINGS:

PLATE WITH ANCHORS

DRAWINGS: p. 955





ATENA

DESIGN STAUBACH & KUCKERTZ



MATERIALS:

POWDER COATED STEEL

FIXINGS:

PRE DRILLED FOR ANCHORS

DRAWINGS: p. 953





FOGLIA

DESIGN NONIS + MASTRORILLI + GOZZETTI



MATERIALS:

POWDER COATED STEEL

FIXINGS:

PRE DRILLED FOR ANCHORS

DRAWINGS: p. 960 - 961





GPDUE

DESIGN LABORATORIO DI ARCHITETTURA ARCHITETTI
ASSOCIATI, ANDREA RINALDI, ROBERTA CASARINI



MATERIALS:

POWDER COATED STEEL

FIXINGS:

PLATE WITH ANCHORS

DRAWINGS: p. 964



GPDUE

DESIGN LABORATORIO DI ARCHITETTURA ARCHITETTI
ASSOCIATI, ANDREA RINALDI, ROBERTA CASARINI







PRAÇA DO TREM
PRAÇA DAS FÉRIAS E EVENTOS
REVITALIZAÇÃO DO ENTORNO
DA ESTAÇÃO FERREIA



Prefeitura de
Caxias
Município de 1989



HUT

DESIGN ALFREDO TASCA



MATERIALS:

POWDER COATED STEEL

FIXINGS:

PLATE WITH ANCHORS

DRAWINGS: p. 956 - 957



HUT

DESIGN ALFREDO TASCA





CITTA DI LUCCA
pianimetria



MERAK

DESIGN PININFARINA



MATERIALS:

POWDER COATED STEEL

FIXINGS:

PRE DRILLED FOR ANCHORS

DRAWINGS: p. 954



MERAK

DESIGN PININFARINA





CITTÀ DI LUCCA
planimetria

ALHENA

DESIGN PININFARINA



MATERIALS:

POWDER COATED STEEL

FIXINGS:

PRE DRILLED FOR ANCHORS

DRAWINGS: p. 954



OMNIBUS

DESIGN STUDIO COMOLLI E MAFFÈ



MATERIALS:

CORTEN POWDER COATED STEEL OR CORTEN STEEL

FIXINGS:

PRE DRILLED FOR ANCHORS

DRAWINGS: p. 953









PARTNERS

DESIGN ALFREDO TASCA



MATERIALS:

POWDER COATED ALUMINUM + POWDER COATED STEEL

FIXINGS:

PRE DRILLED FOR ANCHORS

DRAWINGS: p. 955

Via XXV Aprile
Via della Cooperazione

IAU
INTERNATIONAL ASTRONOMICAL UNION
The International Astronomical Union is the leading authority on astronomy and astrophysics, and is the largest organization of scientists in the world.

THE UNIVERSE
IS A CONNECTION
ASTRONOMY
2009

INTERNATIONAL YEAR OF
ASTRONOMY
2009
www.astronomy2009.org

Sponsors:
ThalesAlenia Space, CELESTRON, ASI, CNRS, ESA, IAU, INAF, ISRO, JAXA, NASA, NAO, NCS, OAC, ONO, OSO, PANGLOSS, RAS, RGS, SDO, STFC, TASC, UCL, UCLM, UCLP, UCLQ, UCLR, UCLT, UCLV, UCLW, UCLX, UCLY, UCLZ, UCLAA, UCLAB, UCLAC, UCLAD, UCLAE, UCLAF, UCLAG, UCLAH, UCLAI, UCLAJ, UCLAK, UCLAL, UCLAM, UCLAN, UCLAO, UCLAP, UCLAQ, UCLAR, UCLAS, UCLAT, UCLAU, UCLAV, UCLAW, UCLAX, UCLAY, UCLAZ, UCLBA, UCLBB, UCLBC, UCLBD, UCLBE, UCLBF, UCLBG, UCLBH, UCLBI, UCLBJ, UCLBK, UCLBL, UCLBM, UCLBN, UCLBO, UCLBP, UCLBQ, UCLBR, UCLBS, UCLBT, UCLBU, UCLBV, UCLBW, UCLBX, UCLBY, UCLBZ, UCLCA, UCLCB, UCLCC, UCLCD, UCLCE, UCLCF, UCLCG, UCLCH, UCLI, UCLIJ, UCLIK, UCLIL, UCLIM, UCLIN, UCLIO, UCLIP, UCLIQ, UCLIR, UCLIS, UCLIT, UCLIU, UCLIV, UCLIW, UCLIX, UCLIY, UCLIZ, UCLJA, UCLJB, UCLJC, UCLJD, UCLJE, UCLJF, UCLJG, UCLJH, UCLJI, UCLJJ, UCLJK, UCLJL, UCLJM, UCLJN, UCLJO, UCLJP, UCLJQ, UCLJR, UCLJS, UCLJT, UCLJU, UCLJV, UCLJW, UCLJX, UCLJY, UCLJZ, UCLKA, UCLKB, UCLKC, UCLKD, UCLKE, UCLKF, UCLKG, UCLKH, UCLI, UCLIJ, UCLIK, UCLIL, UCLIM, UCLIN, UCLIO, UCLIP, UCLIQ, UCLIR, UCLIS, UCLIT, UCLIU, UCLIV, UCLIW, UCLIX, UCLIY, UCLIZ, UCLLA, UCLLB, UCLLC, UCLLD, UCLLE, UCLLF, UCLLG, UCLLH, UCLLI, UCLLJ, UCLLK, UCLLL, UCLLM, UCLLN, UCLLO, UCLLP, UCLLQ, UCLLR, UCLLS, UCLLT, UCLLU, UCLLV, UCLLW, UCLLX, UCLLY, UCLLZ, UCLMA, UCLMB, UCLMC, UCLMD, UCLME, UCLMF, UCLMG, UCLMH, UCLMI, UCLMJ, UCLMK, UCLML, UCLMM, UCLMN, UCLMO, UCLMP, UCLMQ, UCLMR, UCLMS, UCLMT, UCLMU, UCLMV, UCLMW, UCLMX, UCLMY, UCLMZ, UCLNA, UCLNB, UCLNC, UCLND, UCLNE, UCLNF, UCLNG, UCLNH, UCLNI, UCLNJ, UCLNK, UCLNL, UCLNM, UCLNN, UCLNO, UCLNP, UCLNQ, UCLNR, UCLNS, UCLNT, UCLNU, UCLNV, UCLNW, UCLNX, UCLNY, UCLNZ, UCLOA, UCLOB, UCLOC, UCLOD, UCLOE, UCLOF, UCLOG, UCLOH, UCLOI, UCLOJ, UCLOK, UCLOL, UCLOM, UCLON, UCLOO, UCLOP, UCLOQ, UCLOR, UCLOS, UCLOT, UCLOU, UCLOV, UCLOW, UCLOX, UCLOY, UCLOZ, UCLPA, UCLPB, UCLPC, UCLPD, UCLPE, UCLPF, UCLPG, UCLPH, UCLPI, UCLPJ, UCLPK, UCLPL, UCLPM, UCLPN, UCLPO, UCLPP, UCLPQ, UCLPR, UCLPS, UCLPT, UCLPU, UCLPV, UCLPW, UCLPX, UCLPY, UCLPZ, UCLQA, UCLQB, UCLQC, UCLQD, UCLQE, UCLQF, UCLQG, UCLQH, UCLQI, UCLQJ, UCLQK, UCLQL, UCLQM, UCLQN, UCLQO, UCLQP, UCLQQ, UCLQR, UCLQS, UCLQT, UCLQU, UCLQV, UCLQW, UCLQX, UCLQY, UCLQZ, UCLRA, UCLRB, UCLRC, UCLRD, UCLRE, UCLRF, UCLRG, UCLRH, UCLRI, UCLRJ, UCLRK, UCLRL, UCLRM, UCLRN, UCLRO, UCLRP, UCLRQ, UCLRR, UCLRS, UCLRT, UCLRU, UCLRV, UCLRW, UCLRX, UCLRY, UCLRZ, UCLSA, UCLSB, UCLSC, UCLSD, UCLSE, UCLSF, UCLSG, UCLSH, UCLSI, UCLSJ, UCLSK, UCLSL, UCLSM, UCLSN, UCLSO, UCLSP, UCLSQ, UCLSR, UCLSS, UCLST, UCLSU, UCLSV, UCLSW, UCLSX, UCLSY, UCLSZ, UCLTA, UCLTB, UCLTC, UCLTD, UCLTE, UCLTF, UCLTG, UCLTH, UCLTI, UCLTJ, UCLTK, UCLTL, UCLTM, UCLTN, UCLTO, UCLTP, UCLTQ, UCLTR, UCLTS, UCLTT, UCLTU, UCLTV, UCLTW, UCLTX, UCLTY, UCLTZ, UCLUA, UCLUB, UCLUC, UCLUD, UCLUE, UCLUF, UCLUG, UCLUH, UCLUI, UCLUJ, UCLUK, UCLUL, UCLUM, UCLUN, UCLUO, UCLUP, UCLUQ, UCLUR, UCLUS, UCLUT, UCLUU, UCLUV, UCLUW, UCLUX, UCLUY, UCLUZ, UCLVA, UCLVB, UCLVC, UCLVD, UCLVE, UCLVF, UCLVG, UCLVH, UCLVI, UCLVJ, UCLVK, UCLVL, UCLVM, UCLVN, UCLVO, UCLVP, UCLVQ, UCLVR, UCLVS, UCLVT, UCLVU, UCLVV, UCLVW, UCLVX, UCLVY, UCLVZ, UCLWA, UCLWB, UCLWC, UCLWD, UCLWE, UCLWF, UCLWG, UCLWH, UCLWI, UCLWJ, UCLWK, UCLWL, UCLWM, UCLWN, UCLWO, UCLWP, UCLWQ, UCLWR, UCLWS, UCLWT, UCLWU, UCLWV, UCLWW, UCLWX, UCLWY, UCLWZ, UCLXA, UCLXB, UCLXC, UCLXD, UCLXE, UCLXF, UCLXG, UCLXH, UCLXI, UCLXJ, UCLXK, UCLXL, UCLXM, UCLXN, UCLXO, UCLXP, UCLXQ, UCLXR, UCLXS, UCLXT, UCLXU, UCLXV, UCLXW, UCLXZ, UCLYA, UCLYB, UCLYC, UCLYD, UCLYE, UCLYF, UCLYG, UCLYH, UCLYI, UCLYJ, UCLYK, UCLYL, UCLYM, UCLYN, UCLYO, UCLYP, UCLYQ, UCLYR, UCLYS, UCLYT, UCLYU, UCLYV, UCLYW, UCLYZ, UCLZA, UCLZB, UCLZC, UCLZD, UCLZE, UCLZF, UCLZG, UCLZH, UCLZI, UCLZJ, UCLZK, UCLZL, UCLZM, UCLZN, UCLZO, UCLZP, UCLZQ, UCLZR, UCLZS, UCLZT, UCLZU, UCLZV, UCLZW, UCLZX, UCLZY, UCLZZ





PENSILIS 1223, 1722

DESIGN ANTONIO CITTERIO CON TOAN NGUYEN



MATERIALS:

POWDER COATED STEEL

FIXINGS:

PLATE WITH ANCHORS

DRAWINGS: p. 959



Viale Milano





PENSILIS 1223, 1722

DESIGN ANTONIO CITTERIO CON TOAN NGUYEN





brand24
Monitoring Business

Przebieg epidemii koronawirusa
na terenie T waga marki

brand24

📶 📶 📶 📶

Copernicus
AIRPORT WROCLAW

Wrocławskie Centrum
Innowacji i Rozwoju



PENSILIS 1223, 1722

DESIGN ANTONIO CITTERIO CON TOAN NGUYEN





SELF

DESIGN ALFREDO TASCA + MATTIA LI POMI

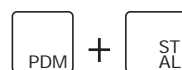

MATERIALS:

RECONSTITUTED STONES + POWDER COATED STEEL

FINISHES:

SMOOTH SEAT AND SANDBLASTED SIDES

FIXINGS:

FREE STANDING

DRAWINGS: p. 966

DETAIL:

FIXING DETAIL OF THE PERFORMANCE CONCRETE (HPC)
SEATS TO THE STRUCTURE



DETAIL:

SANDWICH PANEL COVER



DETAIL:

ACID-ETCHED GLASS COVER



DETAIL:

FIXING DETAIL OF THE GLASS







SINTESI

DESIGN ALFREDO TASCA



MATERIALS:

POWDER COATED STEEL

FIXINGS:

PLATE WITH ANCHORS

DRAWINGS: p. 966





SMART CITY

DESIGN STAUBACH & KUCKERTZ



MATERIALS:

POWDER COATED STEEL

FIXINGS:

PLATE WITH ANCHORS

DRAWINGS: p. 963



SMART CITY

DESIGN STAUBACH & KUCKERTZ







SPACE AUTO

DESIGN ALFREDO TASCA



MATERIALS:

POWDER COATED STEEL

FIXINGS:

PLATE WITH ANCHORS

DRAWINGS: p. 962





SPACE BICI

DESIGN ALFREDO TASCA



MATERIALS:

POWDER COATED STEEL

FIXINGS:

PLATE WITH ANCHORS

DRAWINGS: p. 958



SPACE BICI

DESIGN ALFREDO TASCA







BI



MO

YPSILON

DESIGN ALFREDO TASCA



MATERIALS:

POWDER COATED STEEL

FIXINGS:

PLATE WITH ANCHORS

DRAWINGS: p. 965



joy

PLAYGROUNDS









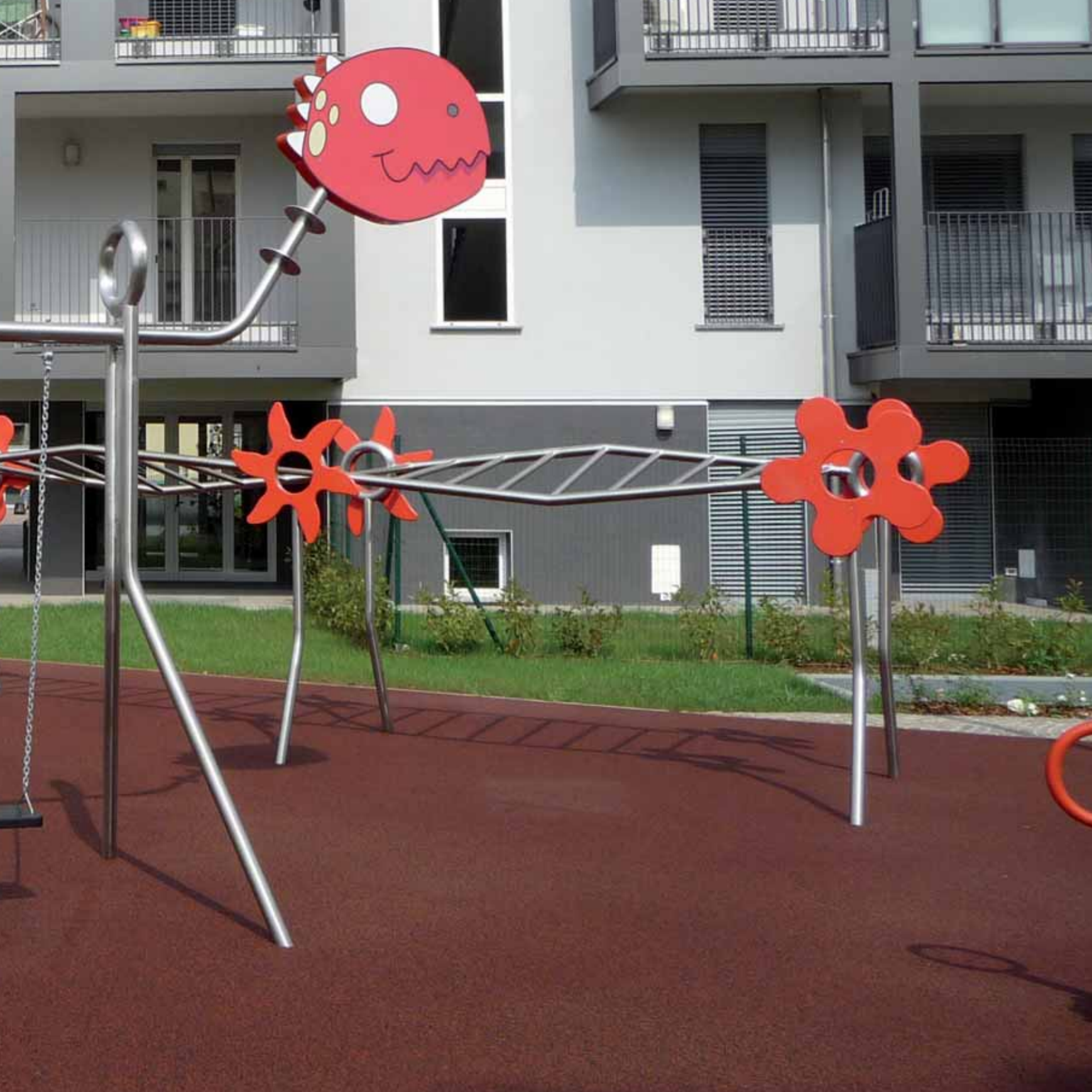





joy

J201, J202, J203

DESIGN STUDIO KUADRA



MATERIALS:

STAINLESS STEEL + HIGH DENSITY POLYETHYLENE +
POWDER COATED ALUMINUM

FIXINGS:

BELOW GROUND INSTALLATION OR PREDRILLED FOR ANCHORS

DRAWINGS: p. 967



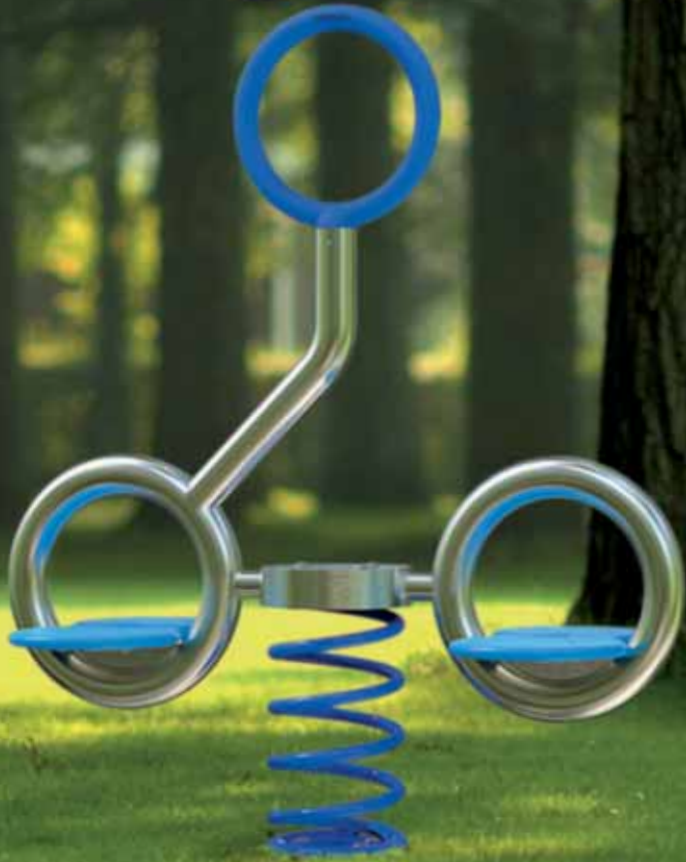

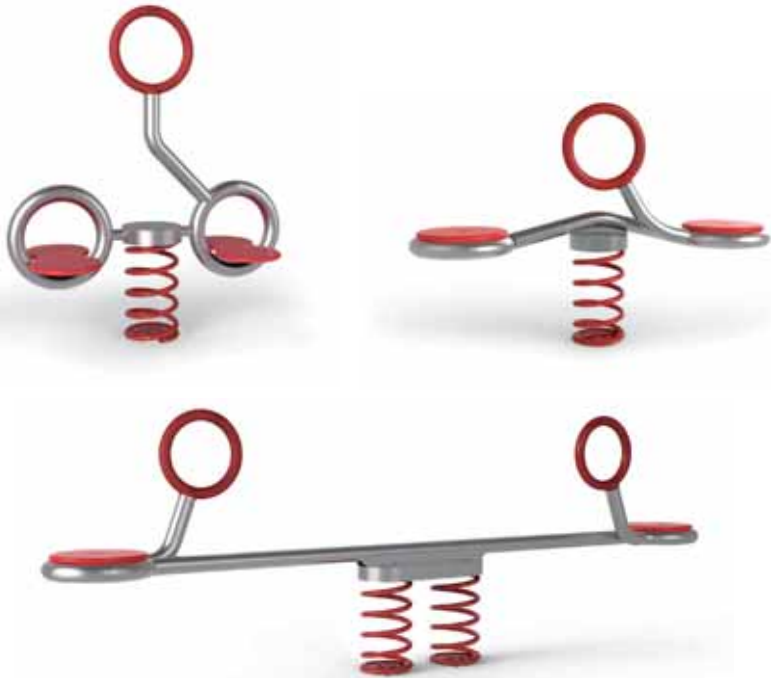

joy

J204, J205, J206

DESIGN STUDIO KUADRA



MATERIALS:

STAINLESS STEEL + HIGH DENSITY POLYETHYLENE +
POWDER COATED ALUMINUM

FIXINGS:

BELOW GROUND INSTALLATION OR PREDRILLED FOR ANCHORS

DRAWINGS: p. 967





Just play. Have

joy

J207

DESIGN STUDIO KUADRA



MATERIALS:

STAINLESS STEEL + HIGH DENSITY POLYETHYLENE +
POWDER COATED ALUMINUM

FIXINGS:

BELOW GROUND INSTALLATION OR PREDRILLED FOR ANCHORS

DRAWINGS: p. 967



ve fun. Enjoy the game.
Michael Jordan



joy

J301



MATERIALS:

STAINLESS STEEL + POWDER COATED ALUMINUM

FIXINGS:

BELOW GROUND INSTALLATION OR PREDRILLED FOR ANCHORS

DRAWINGS: p. 968







joy

J102

DESIGN STUDIO KUADRA



MATERIALS:

STAINLESS STEEL + HIGH DENSITY POLYETHYLENE

FIXINGS:

BELOW GROUND INSTALLATION OR PREDRILLED FOR ANCHORS

DRAWINGS: p. 967





joy

J101

DESIGN STUDIO KUADRA



MATERIALS:

STAINLESS STEEL + HIGH DENSITY POLYETHYLENE

FIXINGS:

BELOW GROUND INSTALLATION OR PREDRILLED FOR ANCHORS

DRAWINGS: p. 967









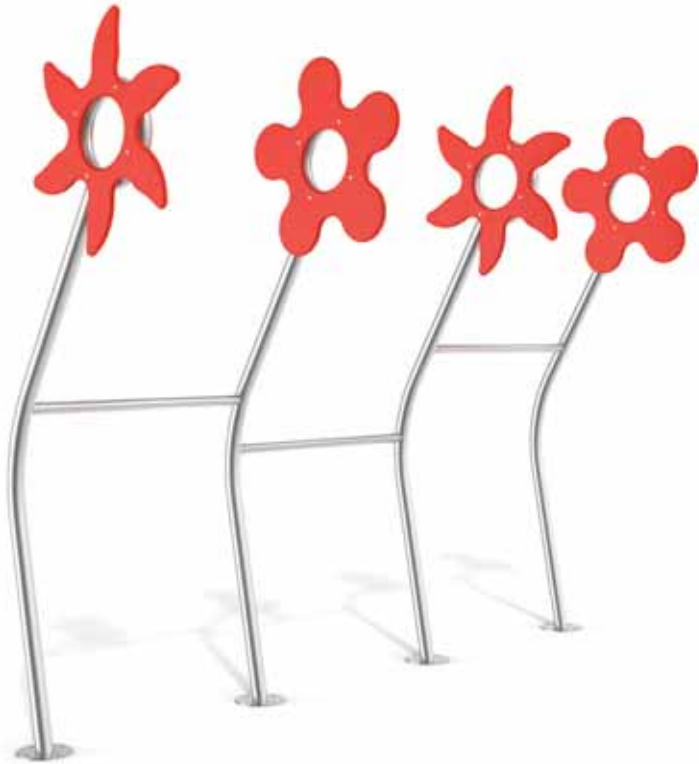

joy

J401

DESIGN STUDIO KUADRA



MATERIALS:

STAINLESS STEEL + HIGH DENSITY POLYETHYLENE +
POWDER COATED ALUMINUM

FIXINGS:

BELOW GROUND INSTALLATION OR PREDRILLED FOR ANCHORS

DRAWINGS: p. 968

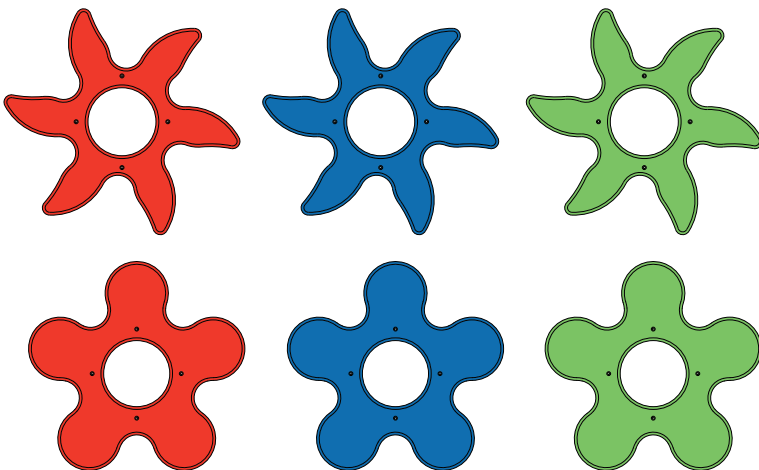





joy

J601

DESIGN STUDIO KUADRA



MATERIALS:

STAINLESS STEEL + HIGH DENSITY POLYETHYLENE +
POWDER COATED ALUMINUM

FIXINGS:

BELOW GROUND INSTALLATION OR PREDRILLED FOR ANCHORS

DRAWINGS: p. 968







joy

J501

DESIGN STUDIO KUADRA



MATERIALS:

STAINLESS STEEL + HIGH DENSITY POLYETHYLENE +
POWDER COATED ALUMINUM

FIXINGS:

BELOW GROUND INSTALLATION OR PREDRILLED FOR ANCHORS

DRAWINGS: p. 968







joy

J402

DESIGN STUDIO KUADRA



MATERIALS:

STAINLESS STEEL + HIGH DENSITY POLYETHYLENE +
POWDER COATED ALUMINUM

FIXINGS:

BELOW GROUND INSTALLATION OR PREDRILLED FOR ANCHORS

DRAWINGS: p. 969

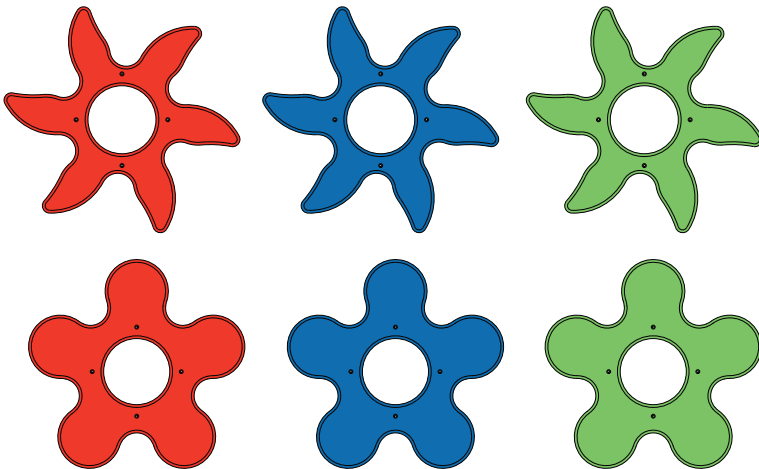







itch
New York



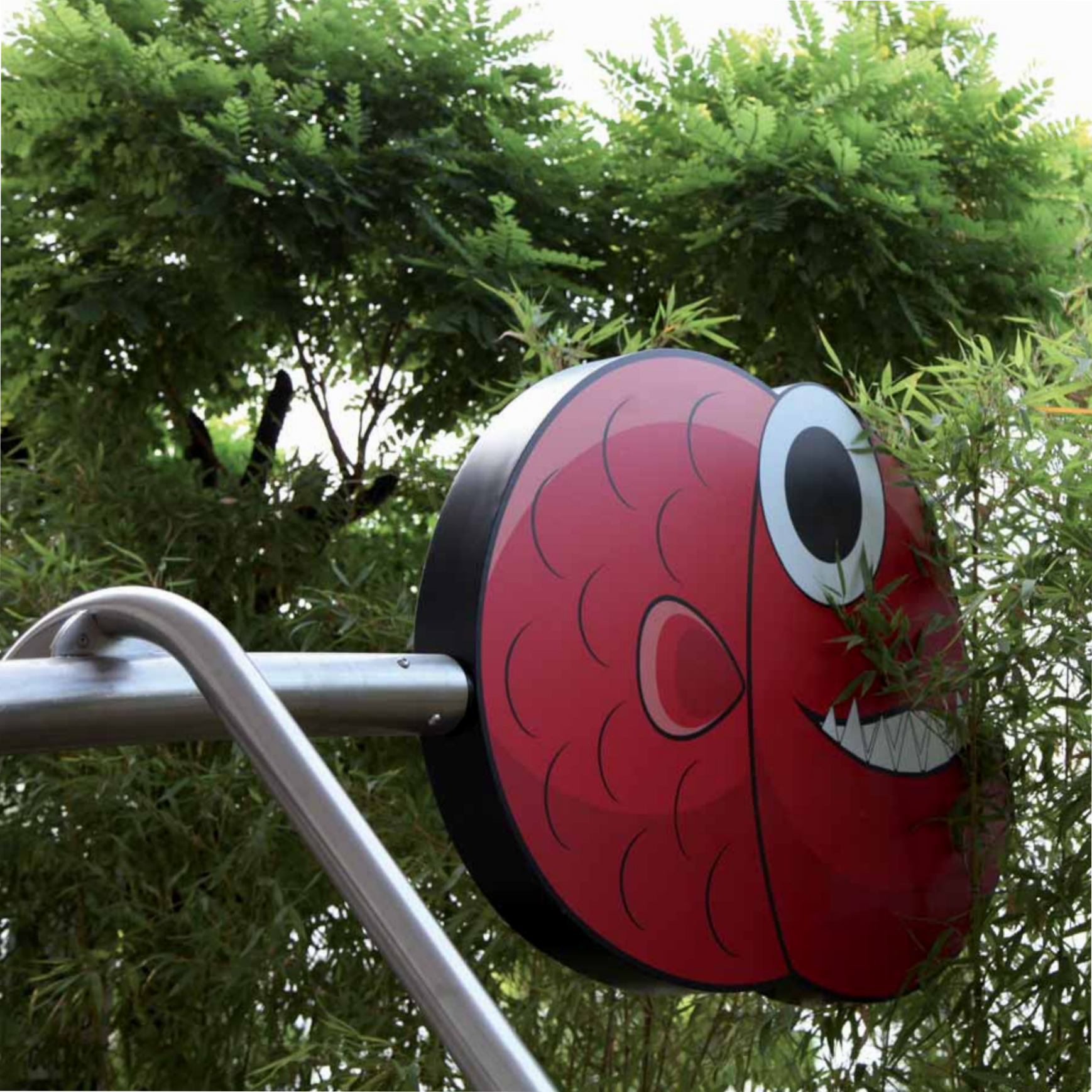

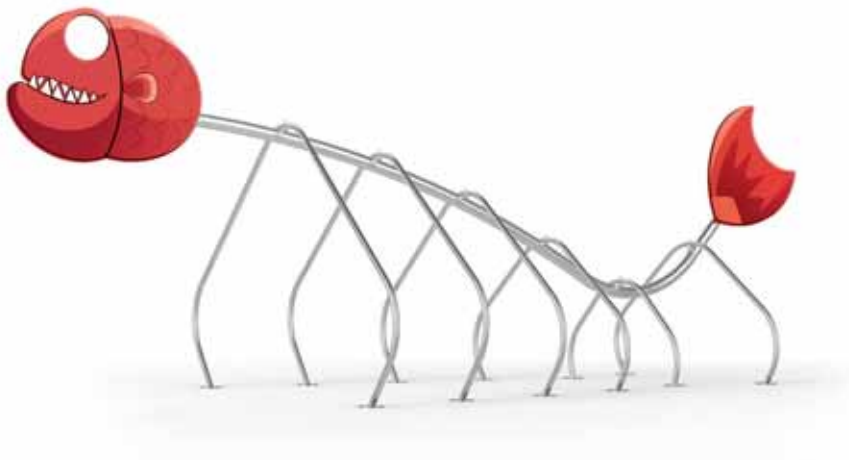

joy

J701

DESIGN STUDIO KUADRA



MATERIALS:

STAINLESS STEEL

FIXINGS:

PRE DRILLED FOR ANCHORS

DRAWINGS: p. 969





METALCO 1984 AILOR ADE

METALCO1984:

Metalco1984, since the very beginning, organizes its structure to bring your ideas and your projects to life, supporting architects and designers with
D D

It is our wish to collaborate with principals and architects, starting from the concept, industrializing productive systems to eternally manufacture, pre-assemble and skillfully install the product.

To meet your requests Metalco uses latest technology equipment and highly skilled professionals in each department, from designer to structural technician, from carpenter to painter, to electrician, from assembler to installer. Our personnel directly manages each phase inclusive the technical support and installation at construction site.

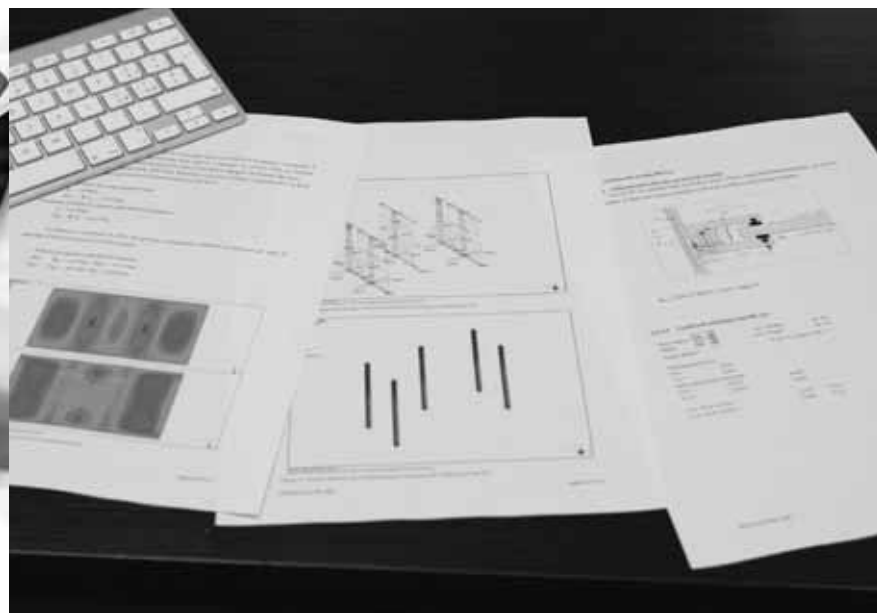



... From the initial telephone call to the installation on site, including the preliminary design, the structural calculation, the mock-up and the construction of the product, following the entire production cycle at our Resana and Castelfranco Veneto factories...

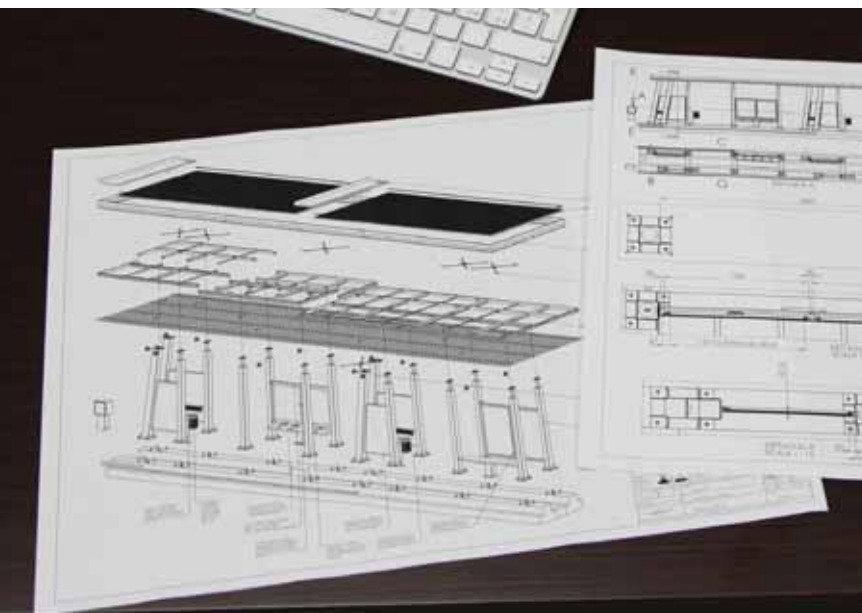







TESLA SUPERCHARGER STATION

AOSTA - ITALY





ZEBRA SHADES

VINCENT GUILLERMIN

GRAU D'AGDE - FRANCE





ZEBRA SHADES

VINCENT GUILLERMIN

GRAU D'AGDE - FRANCE

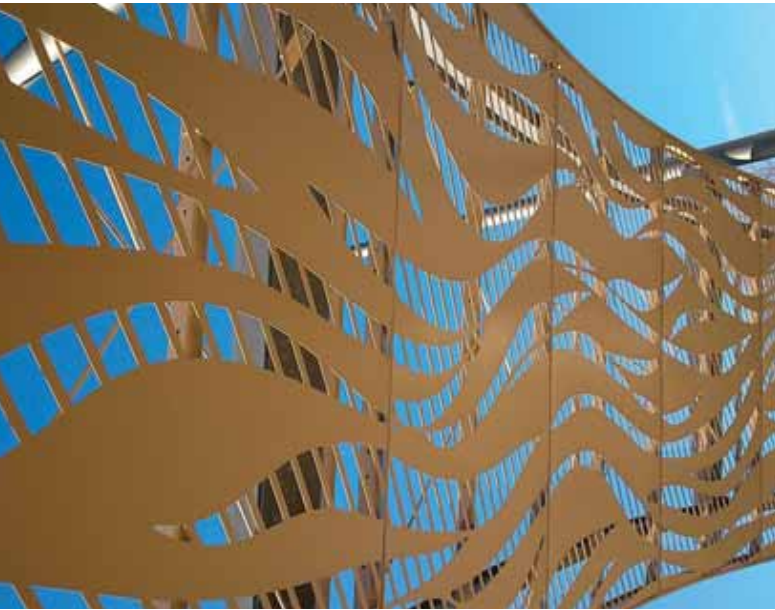



اتجاه عين الدباب النشاطر - الكليات
direction ain dlab plage - Facultes

place nations unies ساحة الأمم المتحدة





TRAMWAY SHELTERS

YOUSSEF NEJMI

CASABLANCA - MOROCCO



TRAMWAY SHELTERS

YOUSSEF NEJMI

CASABLANCA - MOROCCO





Accès interdit

Accès interdit



منوع الولوج





CSL 400 - 100% Durable

Gare de Lyon-Diderot

57 61 91 N 101 32 7

Information
1. Arrêt ouvert 24h
2. Accès handicapés
3. Arrêt sécurisé
4. Arrêt sécurisé à nuit fermée





PUBLIC TRANSIT STATION

AUREL DESIGN URBAN

PARIS - FRANCE - GARE DE LYON DIDEROT



2014
SPECIAL MENTION
GERMAN DESIGN AWARDS



2013
ADI DESIGN INDEX



2013
RECEIVED THE "ETOILE ET LE PRIX
DU DESIGN DE SERVICE DE
L'OBSERVEUR DU DESIGN"



2013
WAS AWARDED WITH THE
"JANUS DE LA PROSPECTIVE"
BY THE INSTITUT FRANÇAIS DU DESIGN



PUBLIC TRANSIT STATION

AUREL DESIGN URBAN

PARIS - FRANCE - GARE DE LYON DIDEROT





CONNESSIONE

Spazio pubblico di ingresso
della biblioteca

Spazio pubblico di ingresso
della biblioteca



RAILWAY STATION

CZ STUDIO ASSOCIATI / ZAMPIERI-CECCON

PADOVA - ITALY



RAILWAY STATION

CZ STUDIO ASSOCIATI / ZAMPIERI-CECCON

PADOVA - ITALY









PUBLIC TRANSIT STATION

FLERS - FRANCE





PUBLIC TRANSIT STATION

FLERS - FRANCE





SHOPINN OUTLET

BRUGNATO 5 TERRE - ITALY



ISOLA URBANA

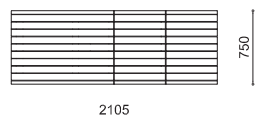
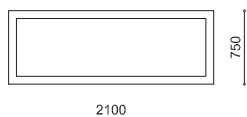
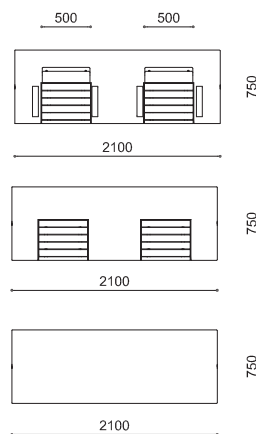
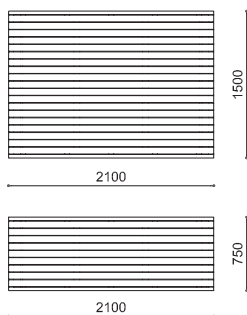

ALTER EGO

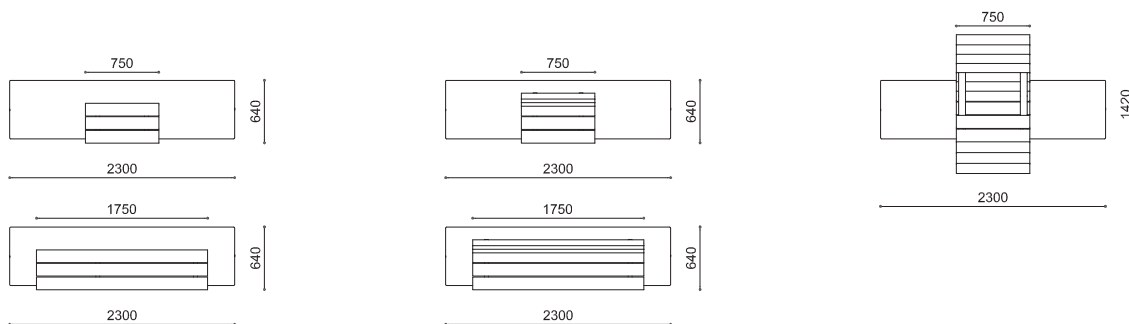
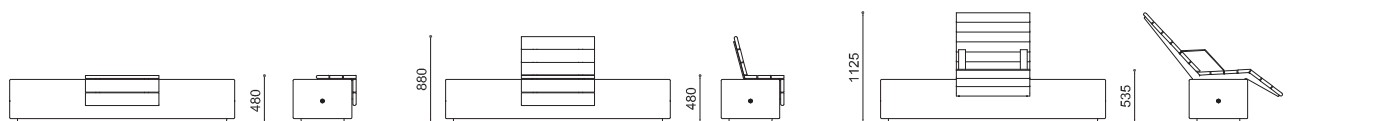

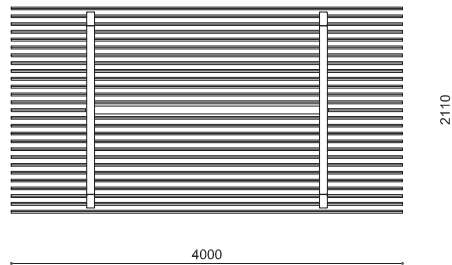
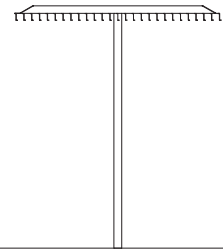
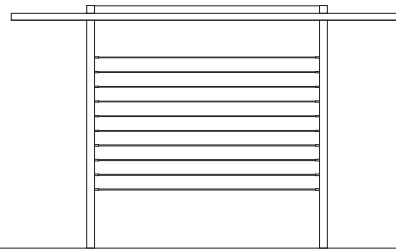
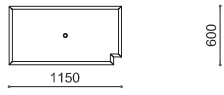
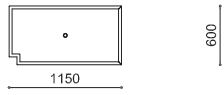
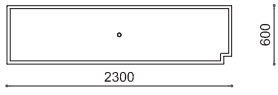
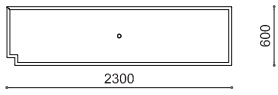
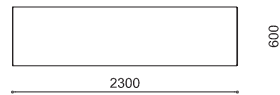
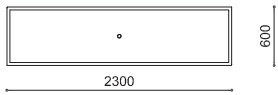

COBRA

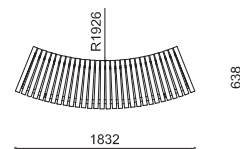
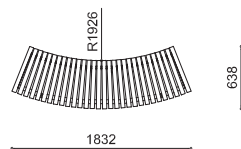
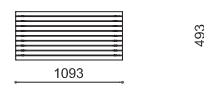
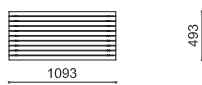
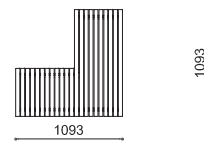
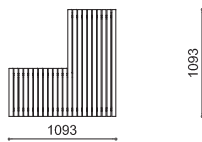
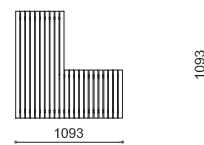
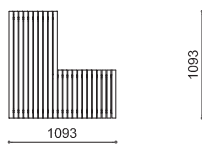

GRANDI FIORIERE

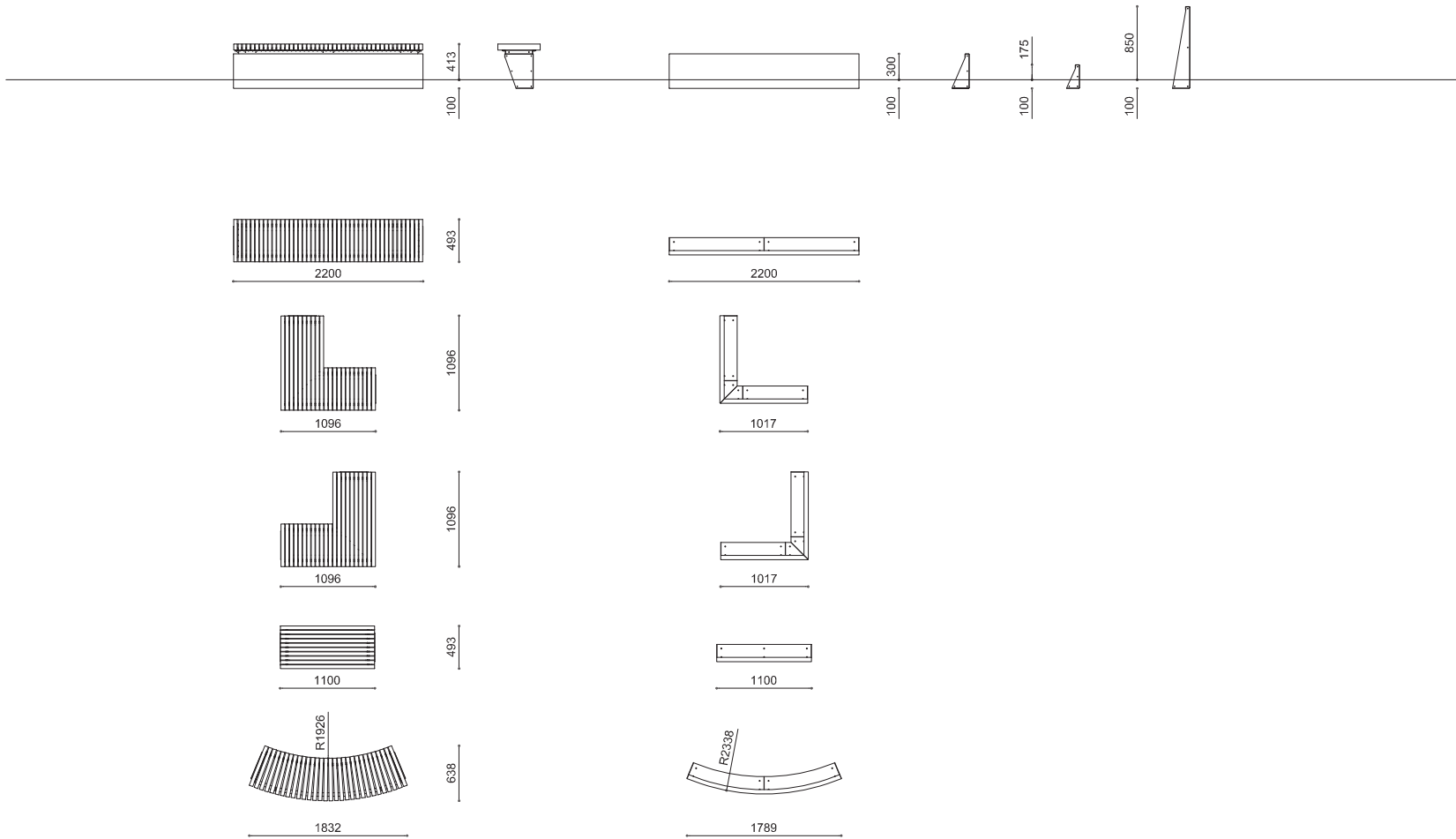

MERENDA

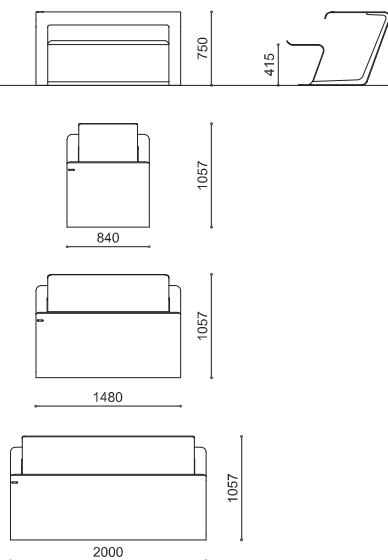

NUVOLA TAVOLO E PANCA

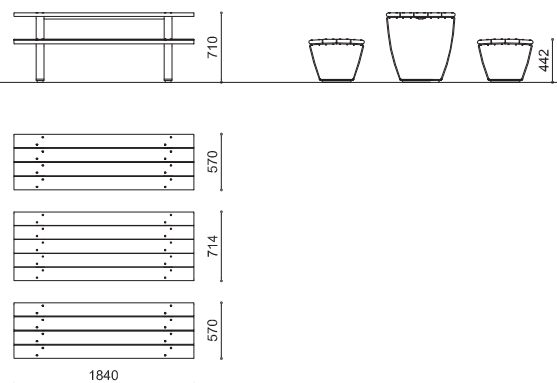

PIC - NIC TAVOLO E PANCA

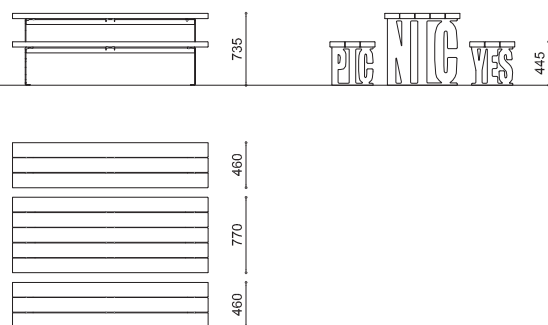

B-BQ

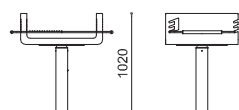

C-BQ

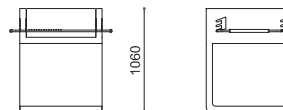

B-B SASS

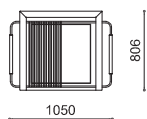
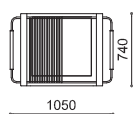

TOSO

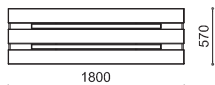

LUCKY

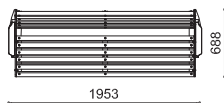
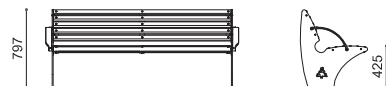

SCULPTURE

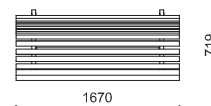
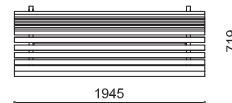
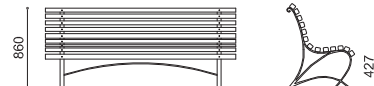

PIC-BULL TAVOLO E PANCA

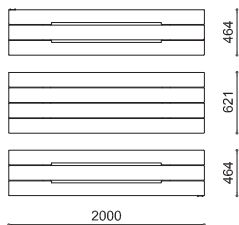
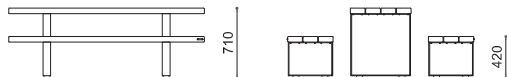

AIR C / AIR C S

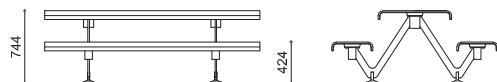

AIR A

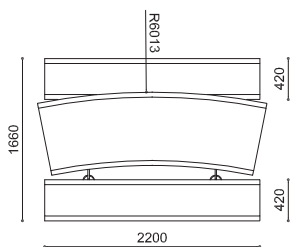
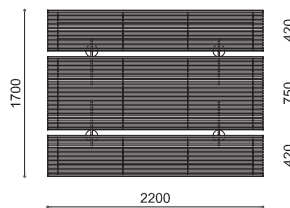
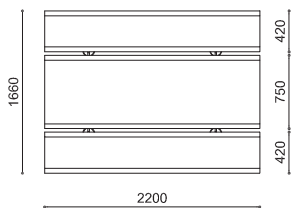
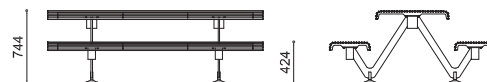

AIR L

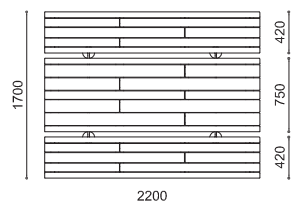
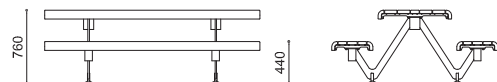

AIR - PORT C

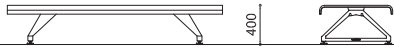

AIR - PORT A

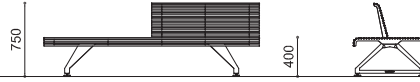

AIR - PORT L

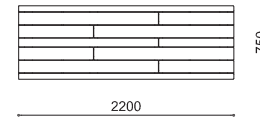
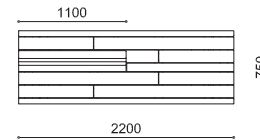
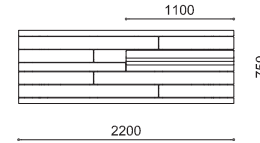
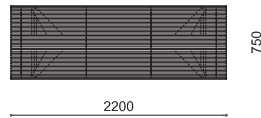
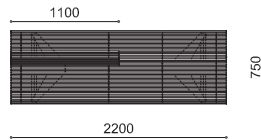
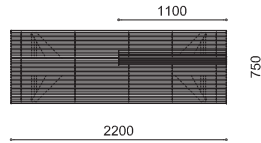
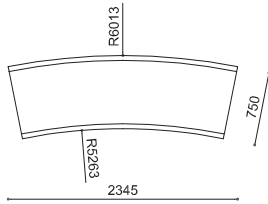
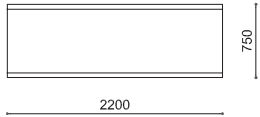
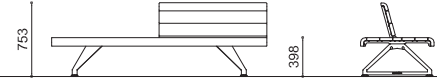

RIVA

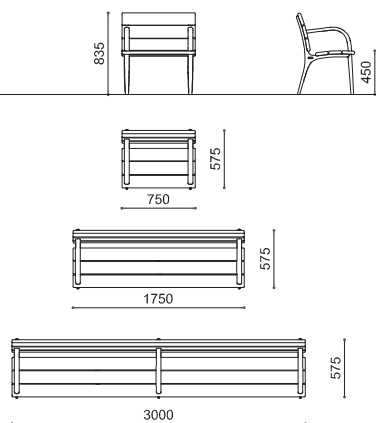

VALENCIA

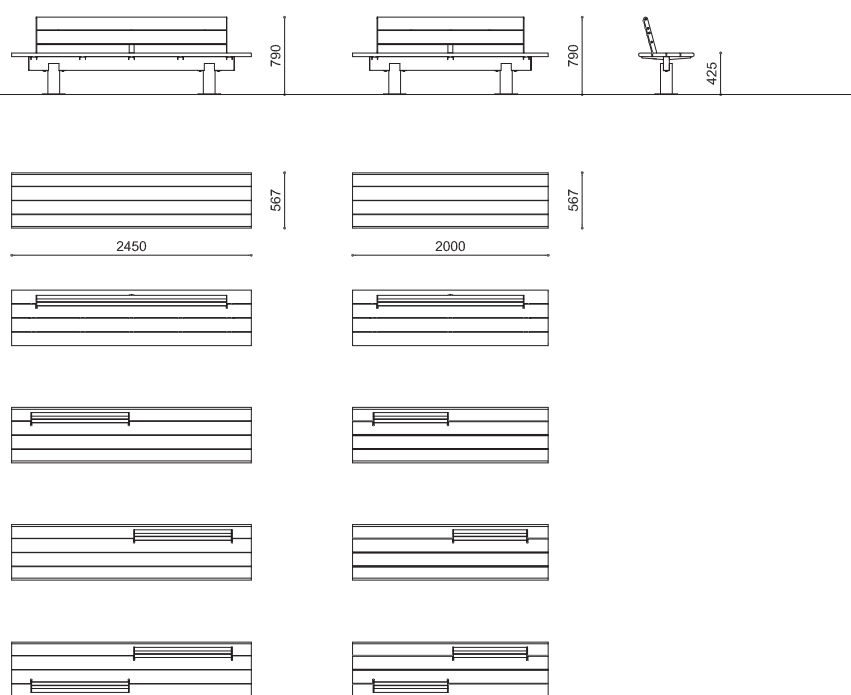

FORESTA

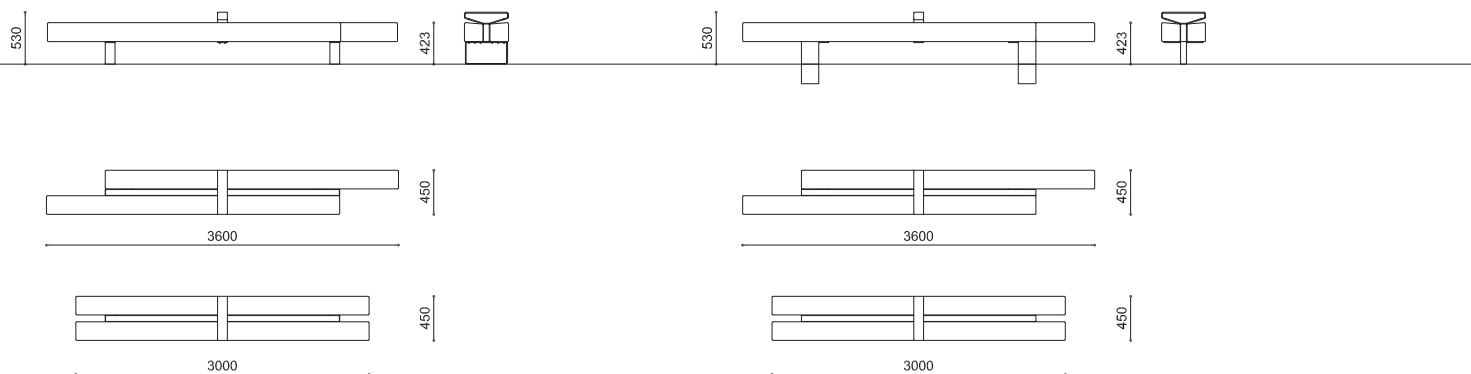

LETTERE

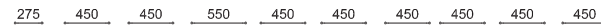
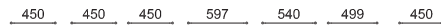
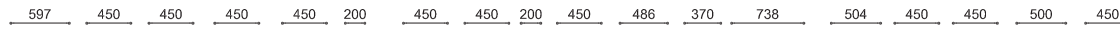

SEDIS

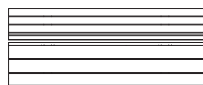
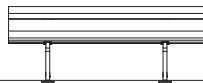

2000

800

SEDIS TORSION

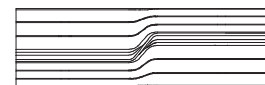
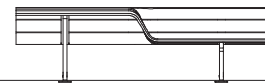

2600

800

TREE LINE CORTO

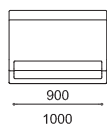
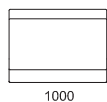
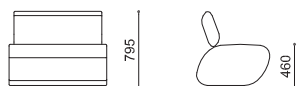

TREE LINE LUNGO

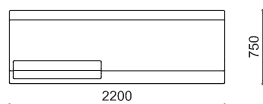
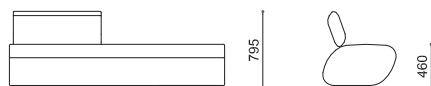

TREE LINE Y

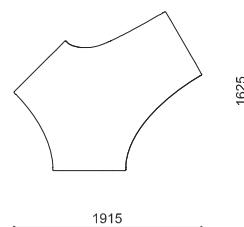
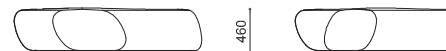

LORENZ

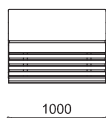
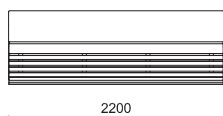

TREE LINE C

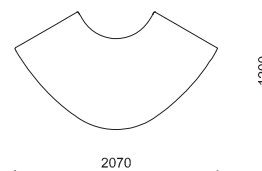

LORENZ C

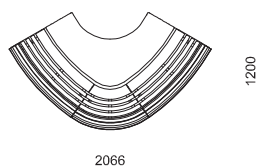

MOONSTONE

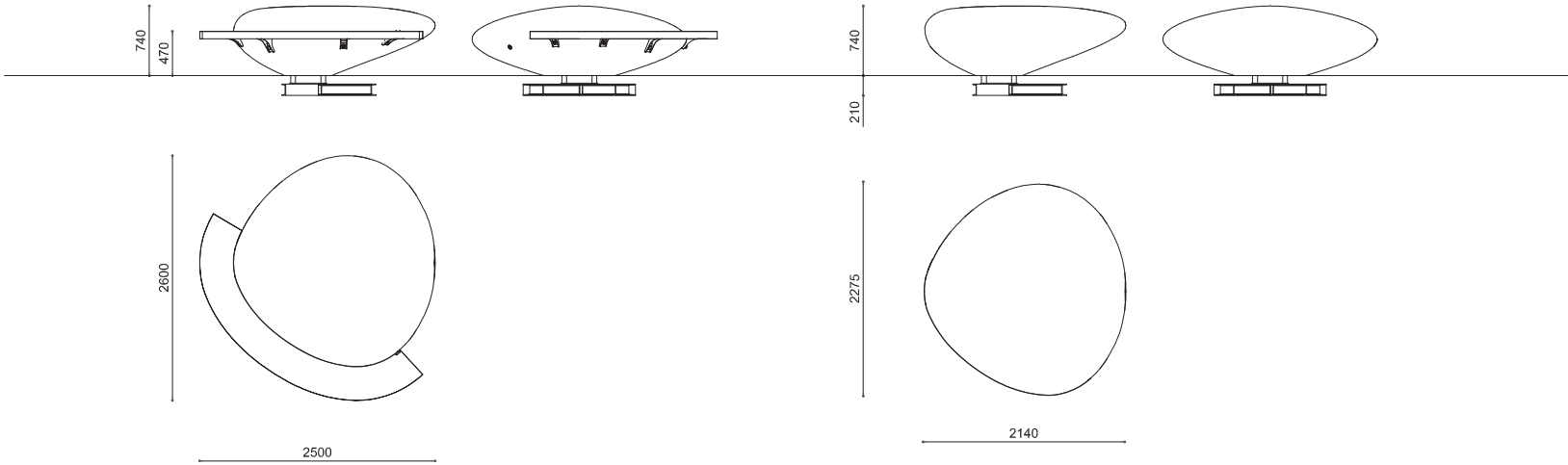

NATURAL

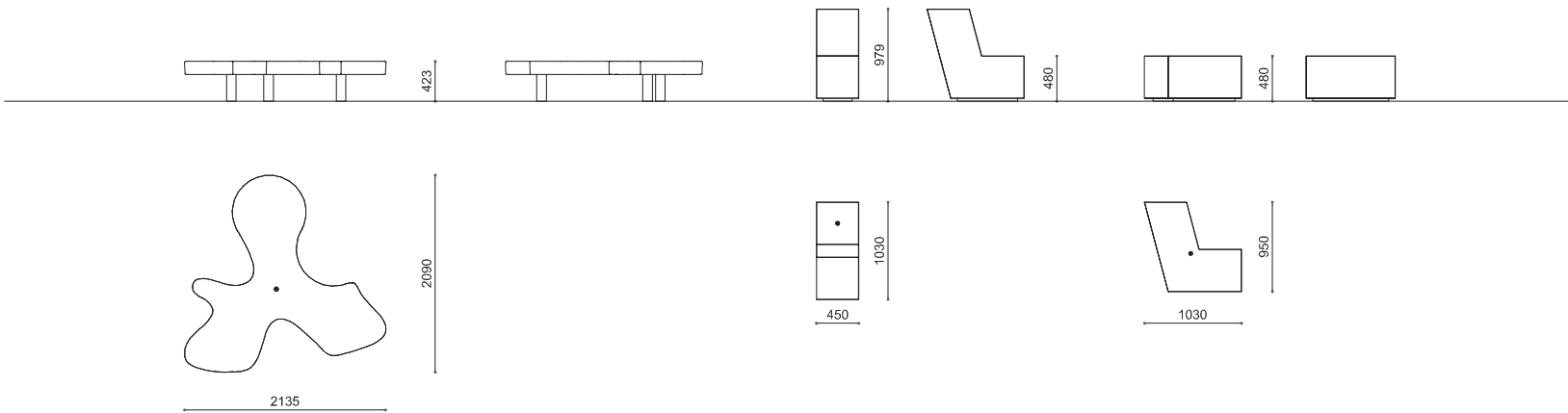

I-BOX COLLECTION

GIADA

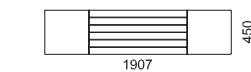
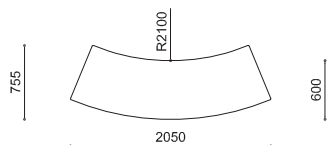
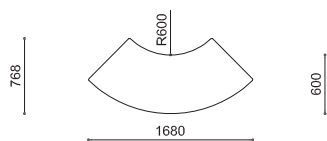
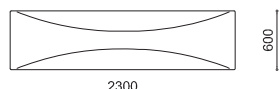
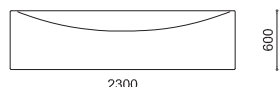
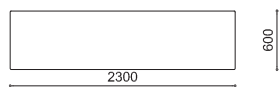
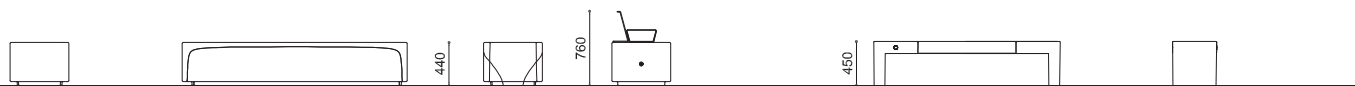

STONE

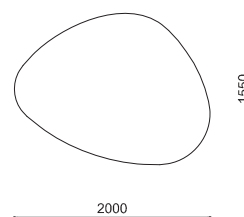

AUSTEN

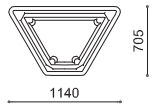
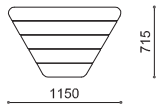
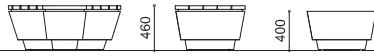

CANN

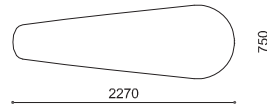
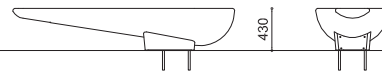

PAD

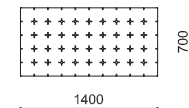

MAMUA'

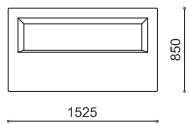
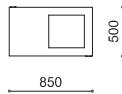
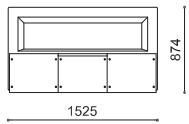
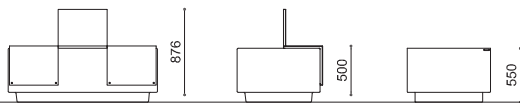

RIVOLA

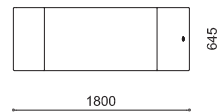

MIZAR S



MIZAR D

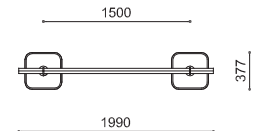

DIANE COLLECTION

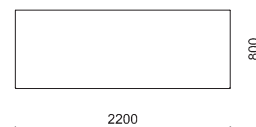
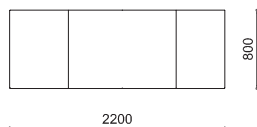
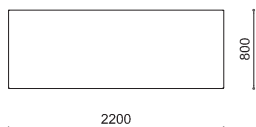

HOBBA

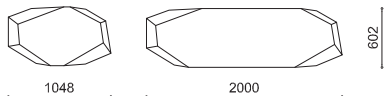
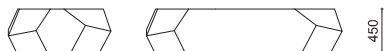

METEOR

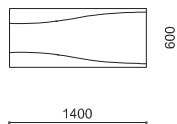

METEOR S

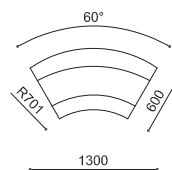
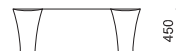

METEOR Y

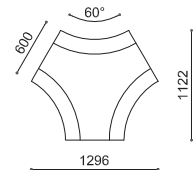

DIAMANTE COLLECTION

DIAMANTE F

DIAMANTE ACCESSORIES W

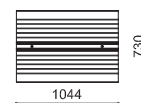
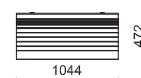
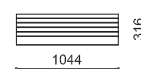
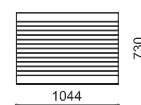
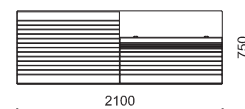
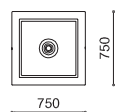
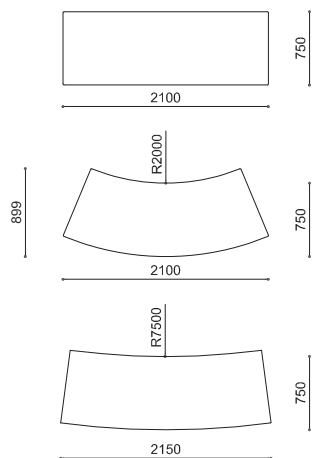
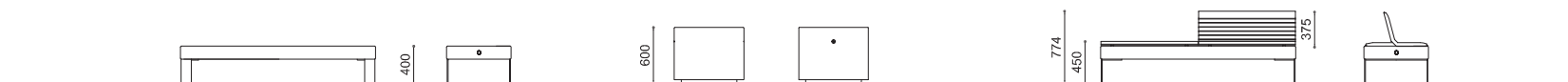

DIAMANTE ACCESSORIES W

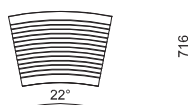
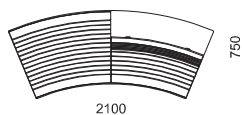
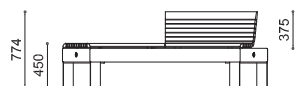

DIAMANTE ACCESSORIES I

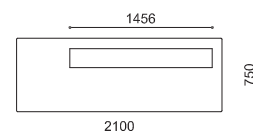
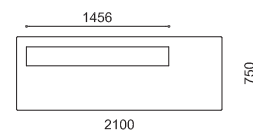
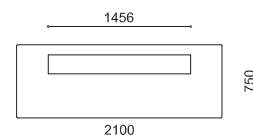
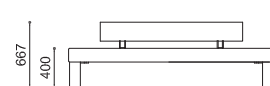
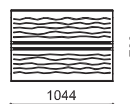
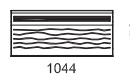
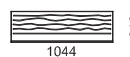
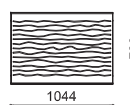
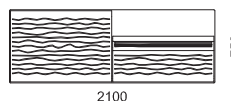
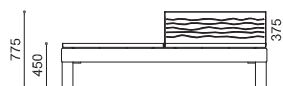

AMBRA

ULURU COLLECTION

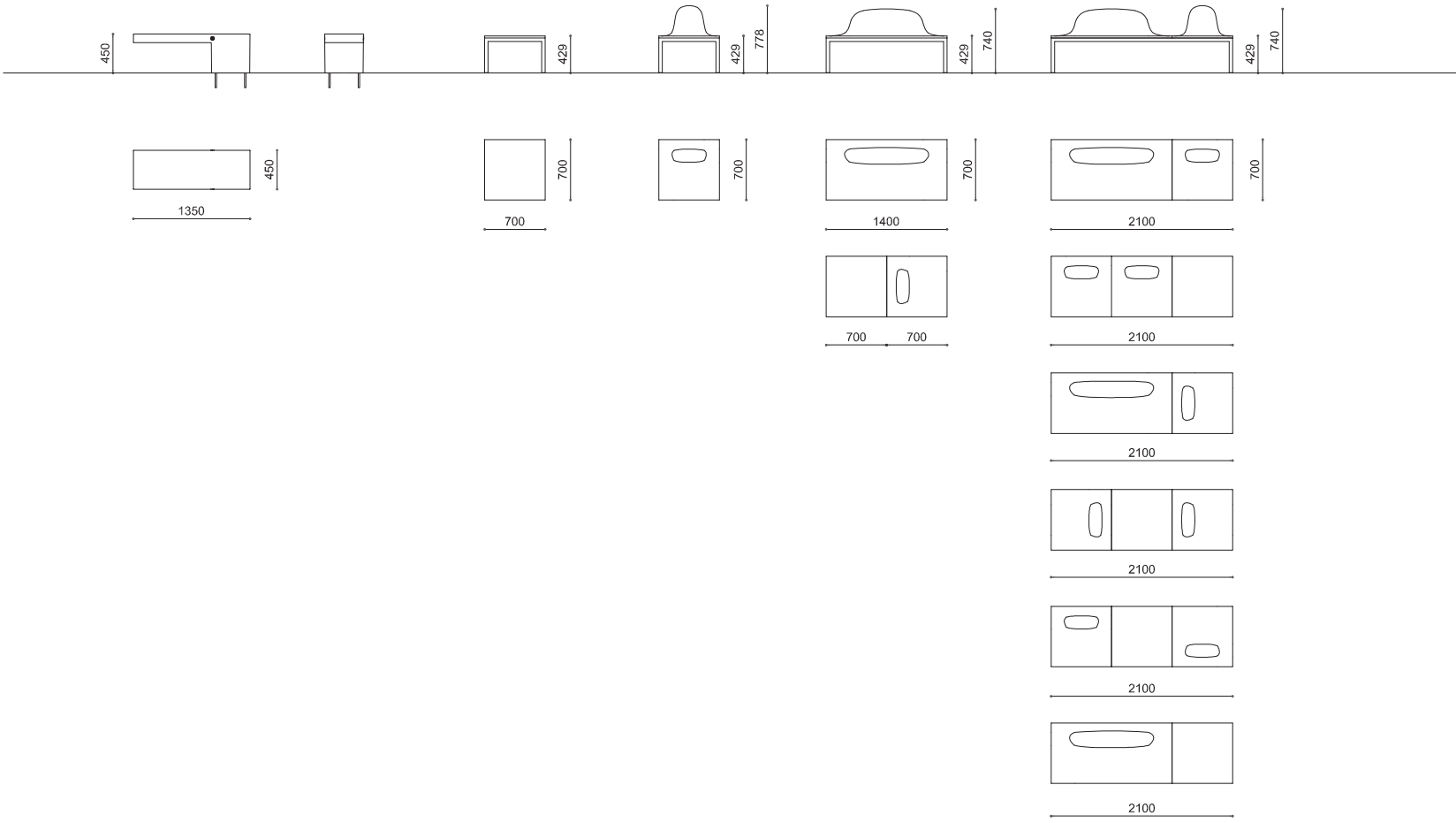

ANASTASIO / MAKATITE / REALGAR

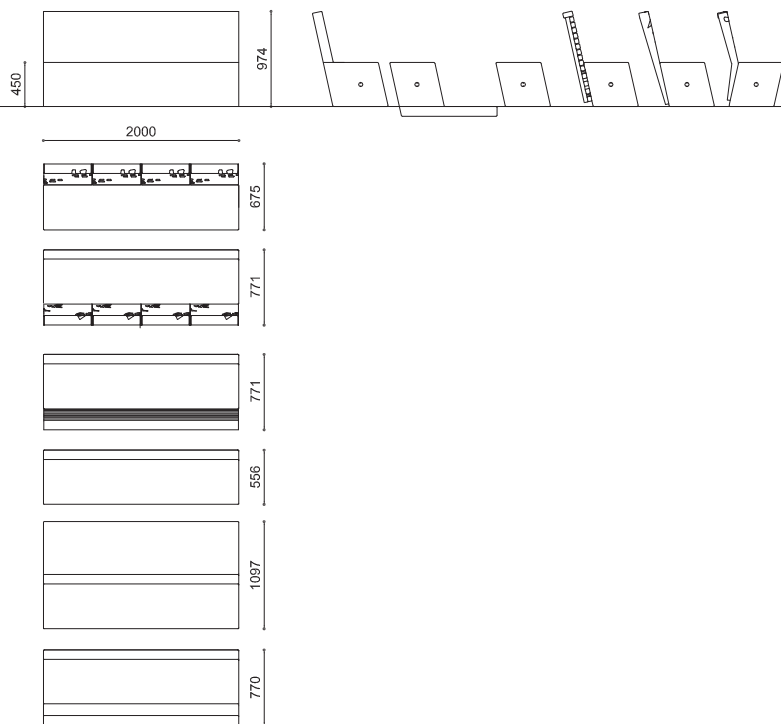

AGATA

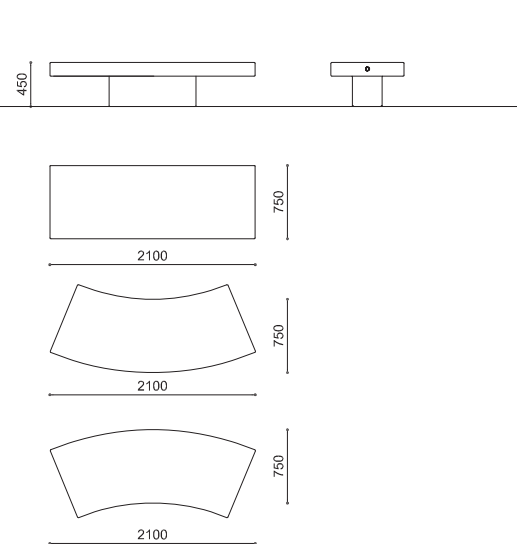

TWIN

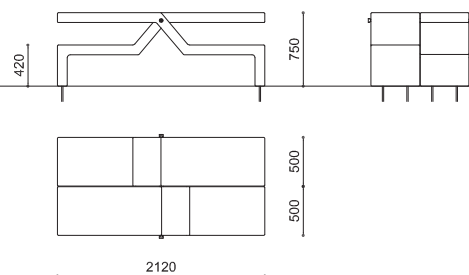

SARAH

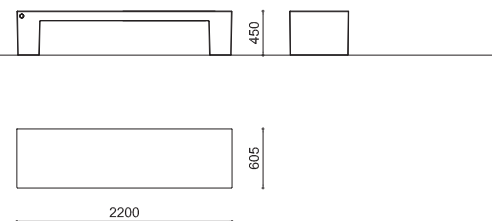

CLUB-A / CLUB-B

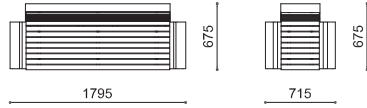
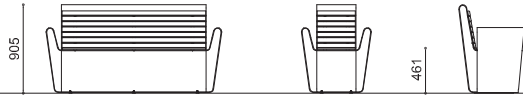

TRONO

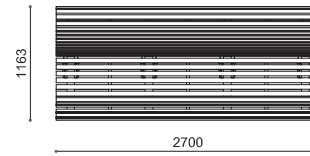
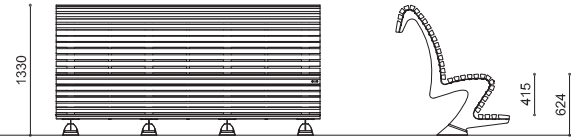

DIVANO

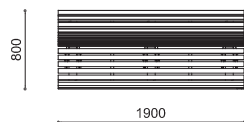
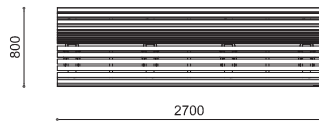
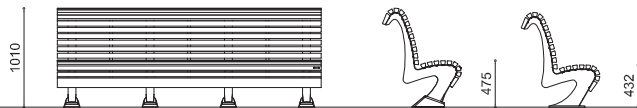

POUF

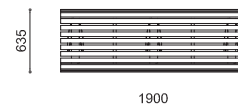
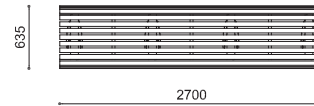

CANAPE'

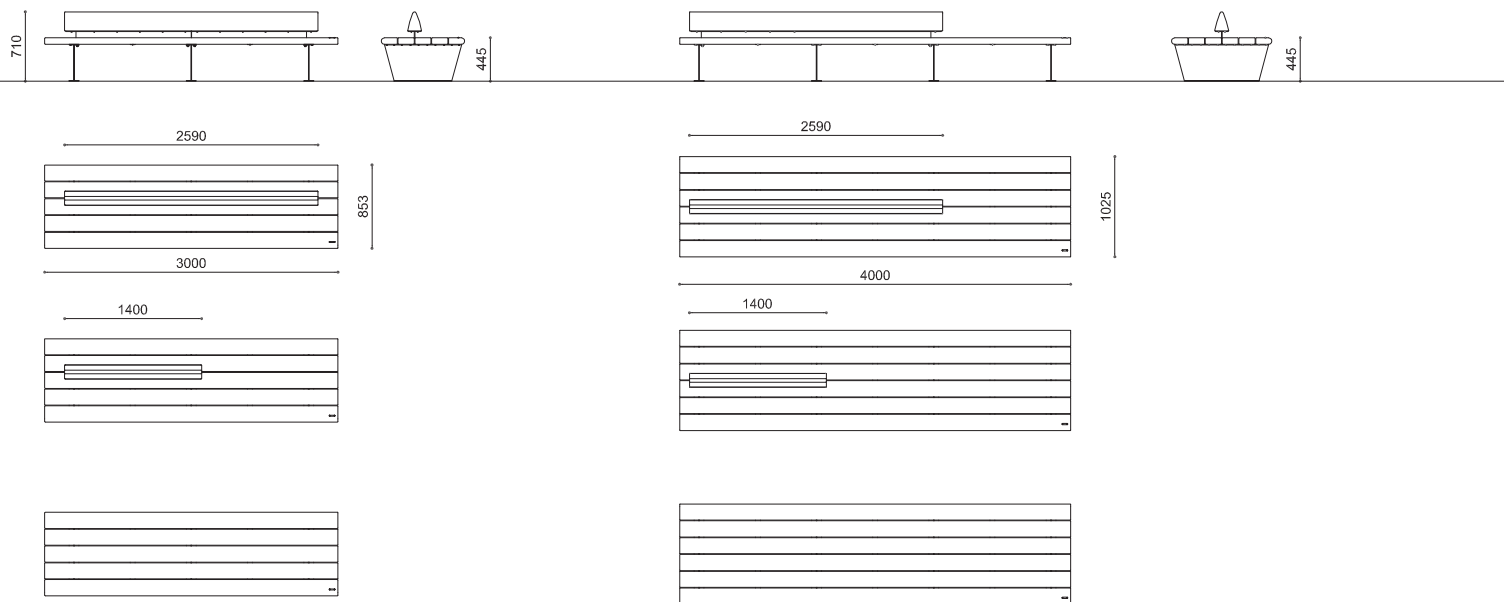

BULL

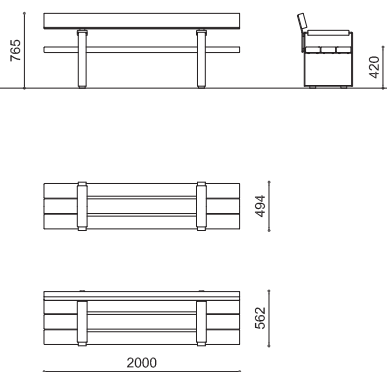

MOOD

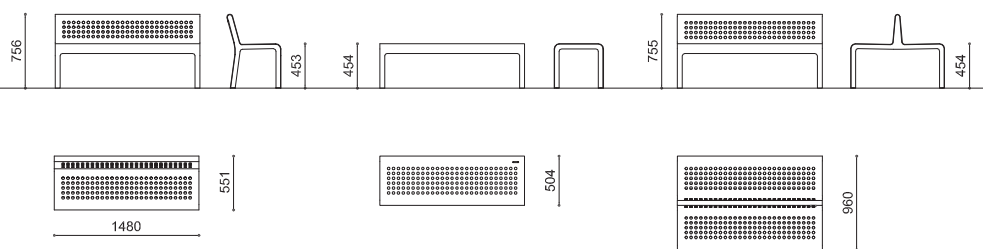

VOLO

DEA / DIVA / LUA / STELLA / ELA

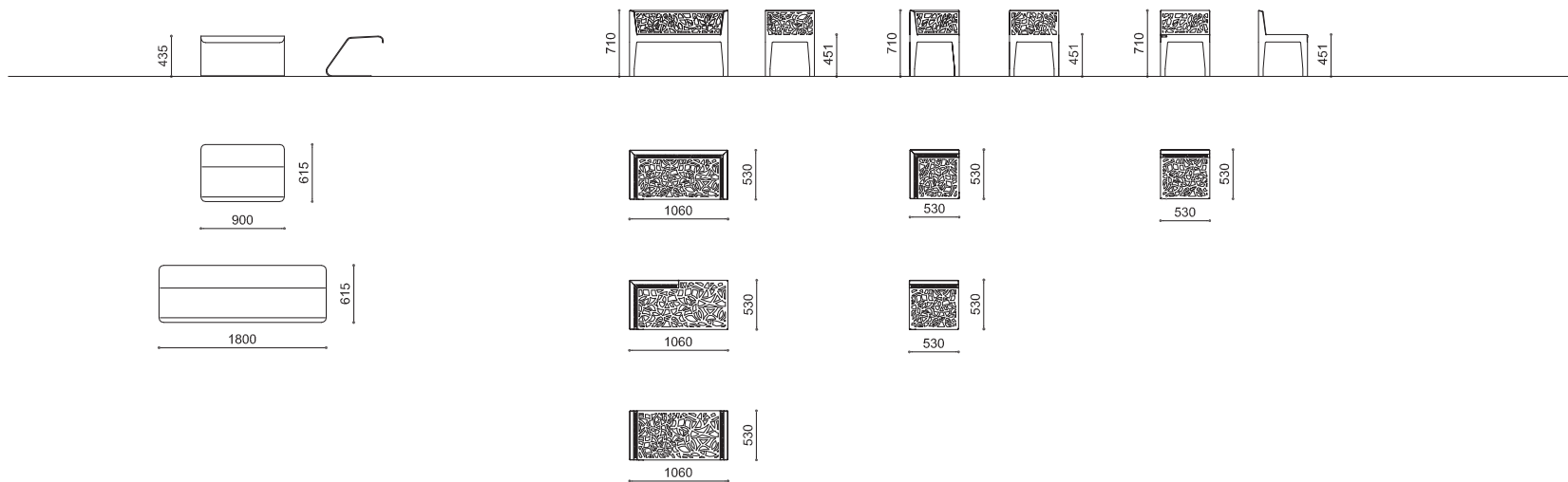

ISOMETRICA

CAMPUS

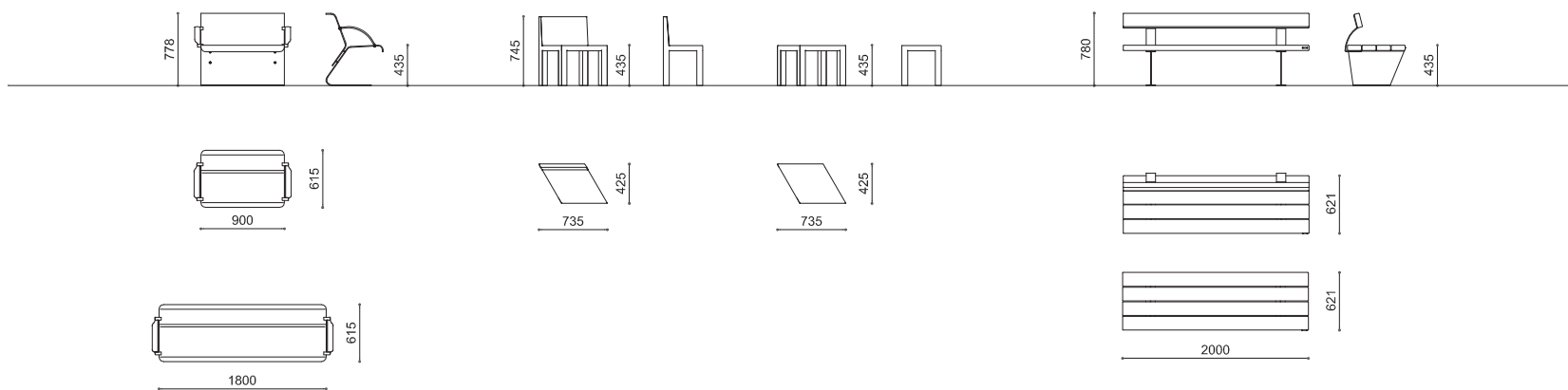

CORTOMADERE

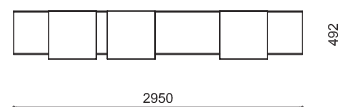
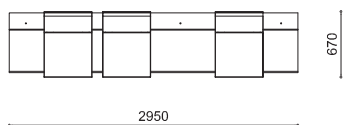

CORTOMADERE

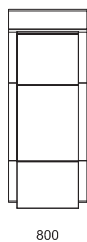
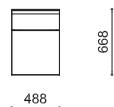
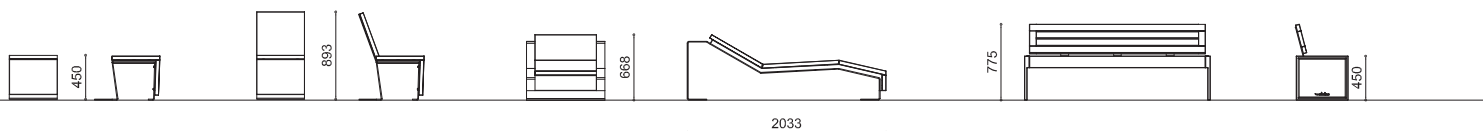

HORN

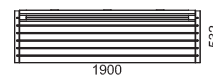
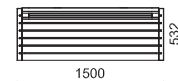
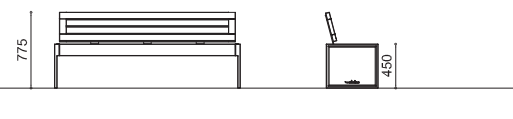

PLATINUM

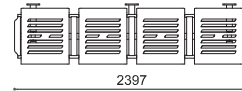
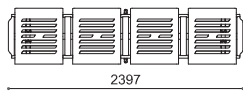
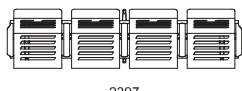
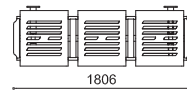
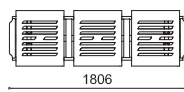
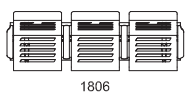
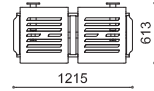
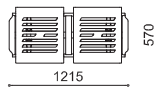
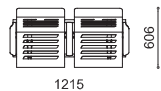
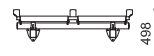
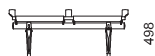
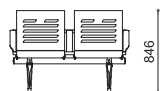

DOMUS

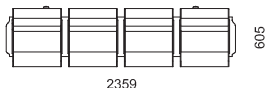
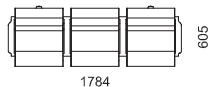
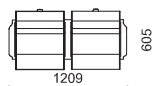
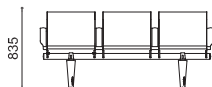

DOMUS ISCHIATICA

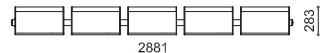
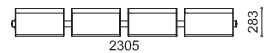
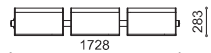
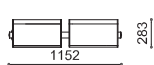
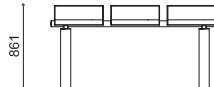

FRECCIA

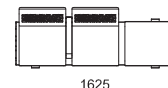
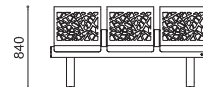

HARRIS

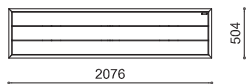
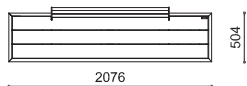
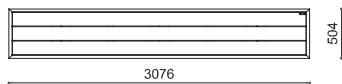
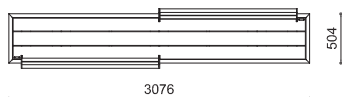

BIG HARRIS

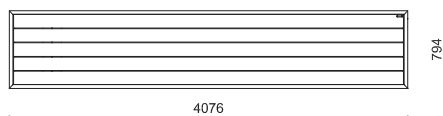
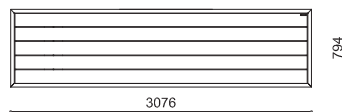
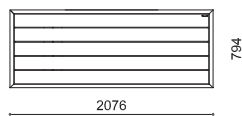
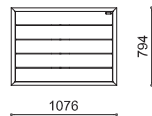

ISOLA HARRIS

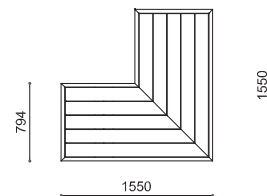
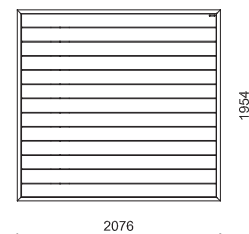
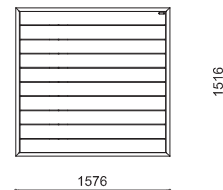

IDEAS - L

IDEAS - T

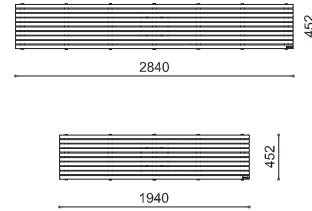
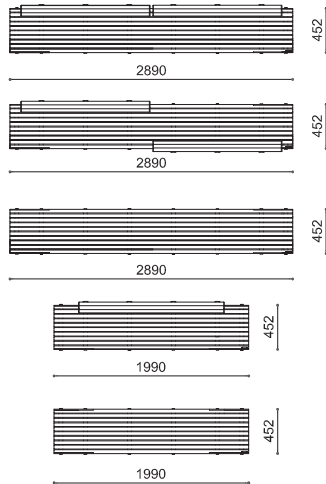
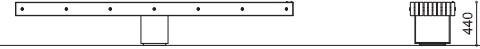
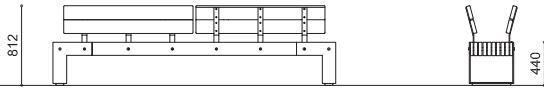

LIBRE EVOLUTION

LIBRE EVOLUTION PIANA

LIBRE EVOLUTION TORSION - HALF

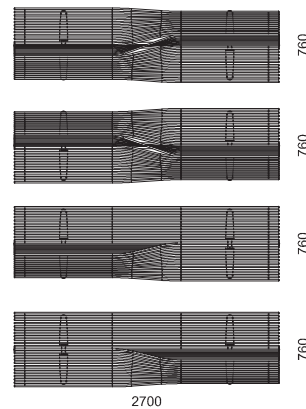
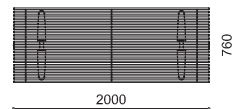
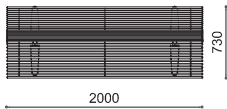
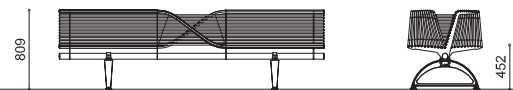
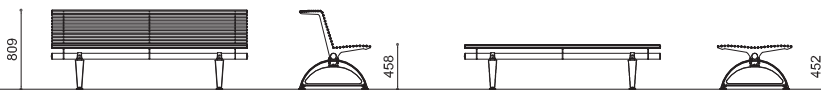

LIBRE / LIBRE SETTORE

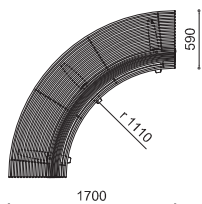
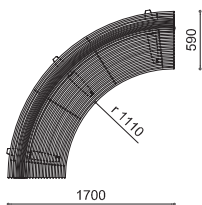
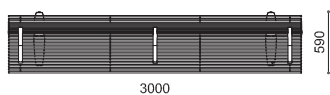
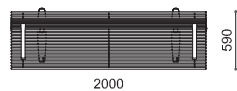
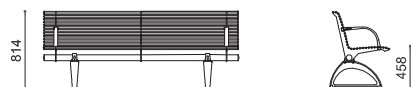

LIBRE PIANA / LIBRE PIANA SETTORE

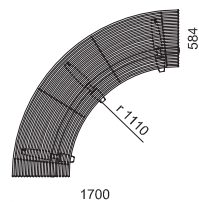
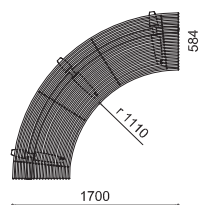
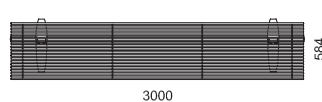
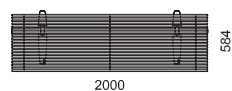

LIBRE DOPPIA / LIBRE DOPPIA SETTORE

LIBRE DOPPIA PIANA / LIBRE DOPPIA PIANA SETTORE

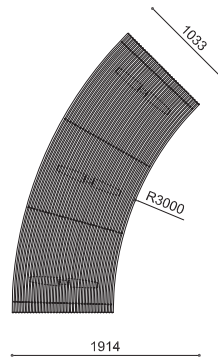
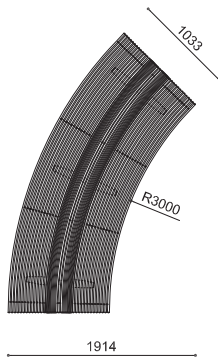
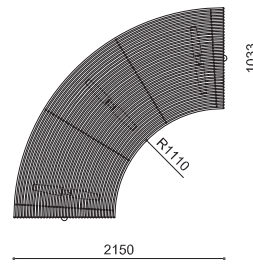
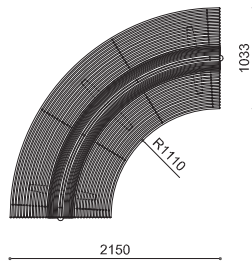
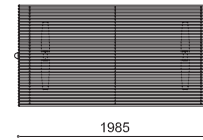
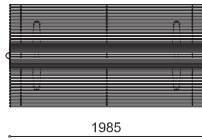
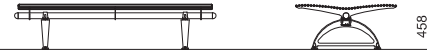
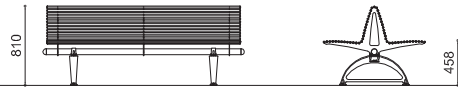

NUVOLA

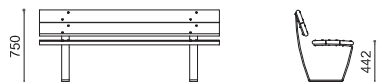

NUVOLA DOUBLE

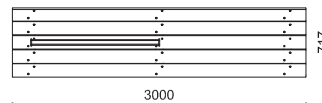

NUVOLA PIANA

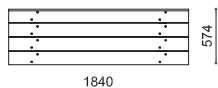

PONTE

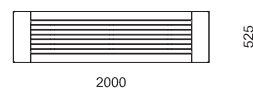

VICTOR

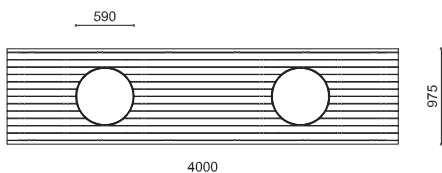

AGORA'

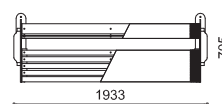

QUARZO

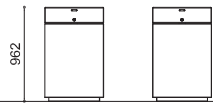

600

RUBINO



520

TOPAZIO

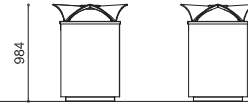

761

CUP

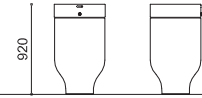

520

GAVITELLO

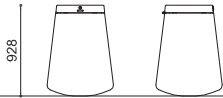

678

BOTTE

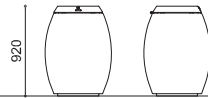

678

POD

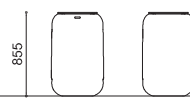

535

ANFORA

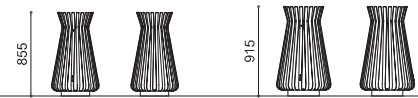

491



559

LANCILLOTTO

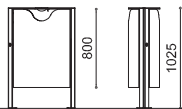

680

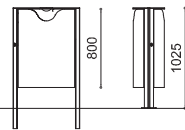

680

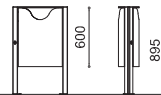

560

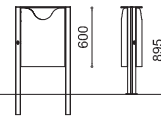

560

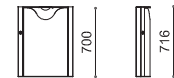

560

SET

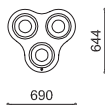

FLOM

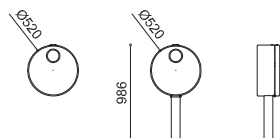

TOM



CESTIS

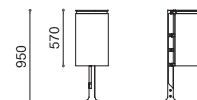

MILLENNIUM

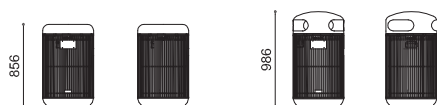

ERCOLE

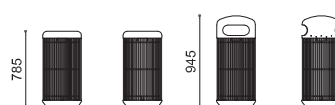

CESTUM

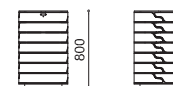

LYS

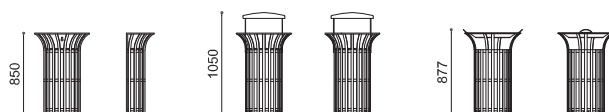

PARK



BIG SPACE

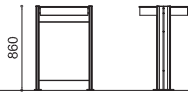

SCUDO

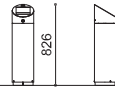

SMOKY

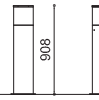

FU'

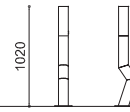

FUMA



BRAVO SLIK

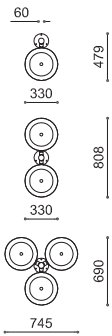
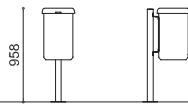

BRAVO HOLE

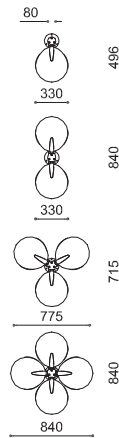
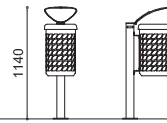

BRAVO BOOM

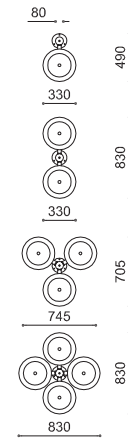
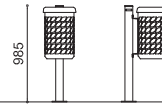

SUPER BRAVO

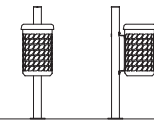

CONGA



C3

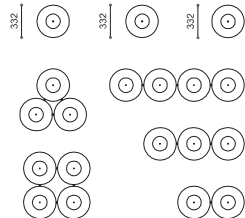
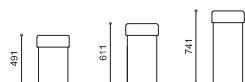

CORTE

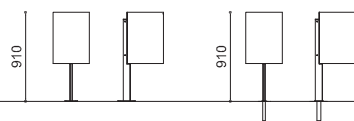

BOX LINE

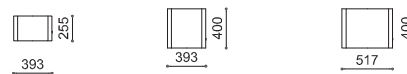
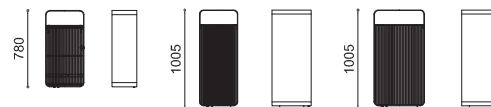

BOX WOOD

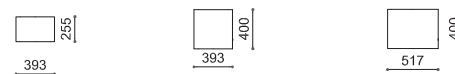
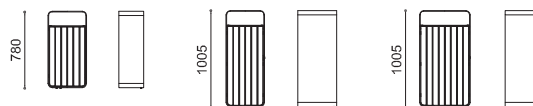

ECOMIX

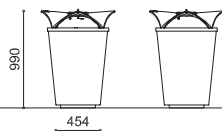

QUBA

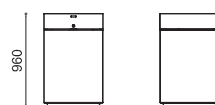

BOX IRON

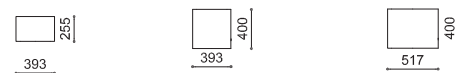
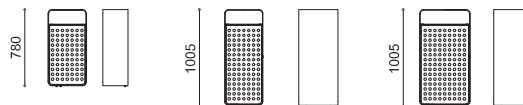

MARTE

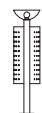
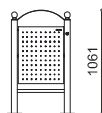

RAINLESS



TULIP / TULIP BIG

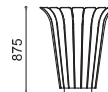

AERO

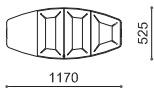
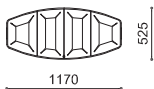
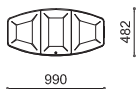

BLOOM



HALLS

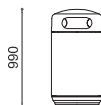

CLUB - C



ERMES

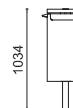
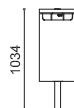
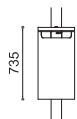

CHANDY

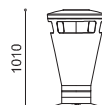

SCRAMBLER

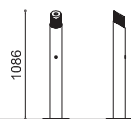

CICA



GENE

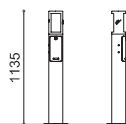

MO

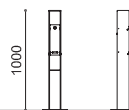

SHANGHAI

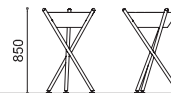

BLADES



YES

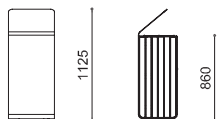

PACK

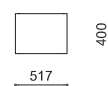
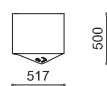
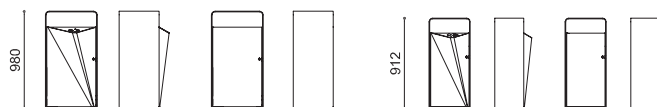

MARCO BOOM



ECOSIDE

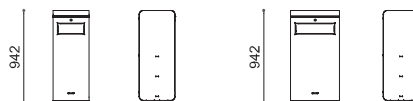

SINGLE FOX

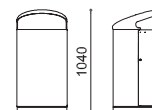

SPENCER CP

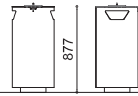
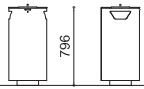

SPENCER CPQ

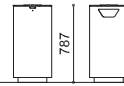

SPENCER CPP

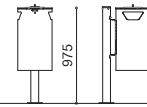

SPENCER

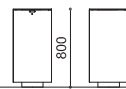
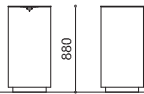

SPENCER-ST

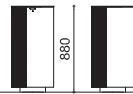

SPENCER-TC

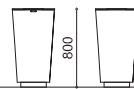

SPENCER-E

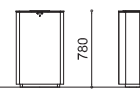

SPENCER-Q

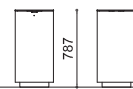

SPENCER-R

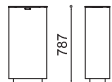

SPENCER-T

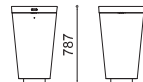

SPENCER-WOOD

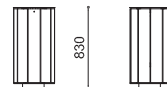

SPENCER-LIBRE

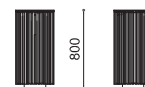

ECO SPENCER

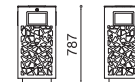

CYCLUS

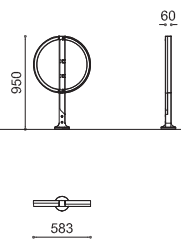

APOLLO



BIKE

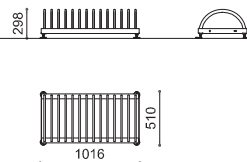

BIKE BOX

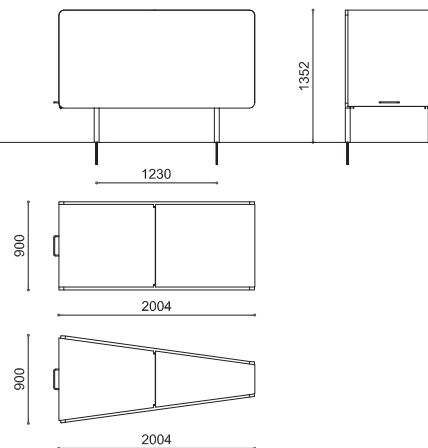

MIKADO

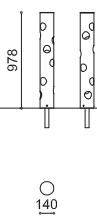

TJADO

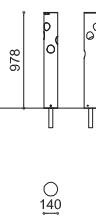

INSIDE

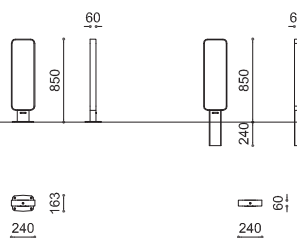

PITSTOP

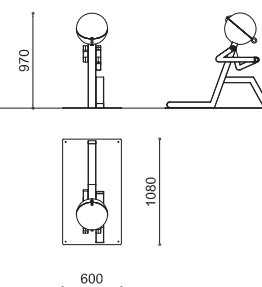

SPYRA

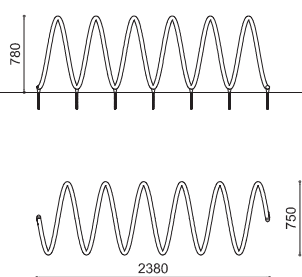

CRUNA

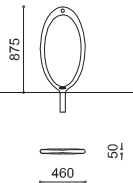

HEAD

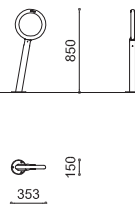

OVAL

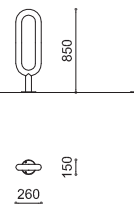

SILVER

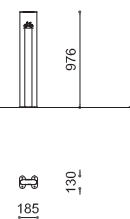

CAFE'

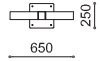
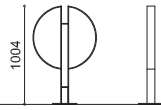

CHIAVE

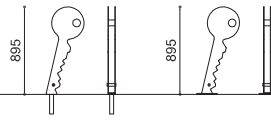

SMERALDO

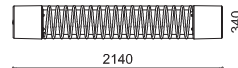

CICLOS

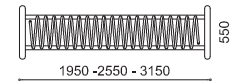
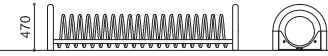

CIRCLE

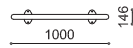
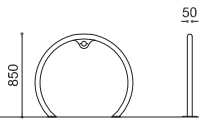

BLAKE

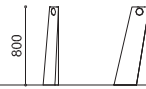

GOMMA

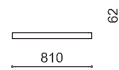
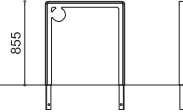

RUBB

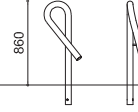

LUCCHETTO

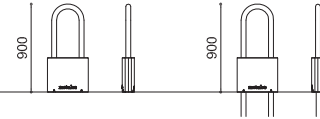

MOVE



RESET

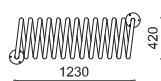
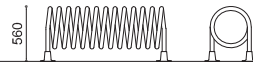

TYPE



CLOS

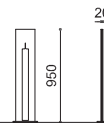

GUARDIA

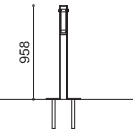

SPRING P

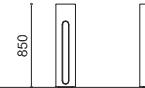

BIPLANO

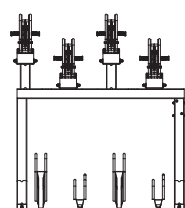

1710



3057

1578

2195

2620

6830

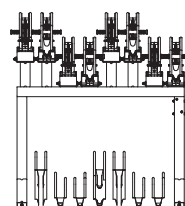

1710

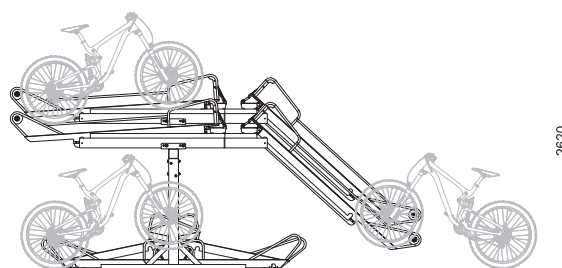

862

3340

862

2620

5064

CARPI

SIGARO

ONORIUS

ISTRA

QUICK

MOKA



DIX

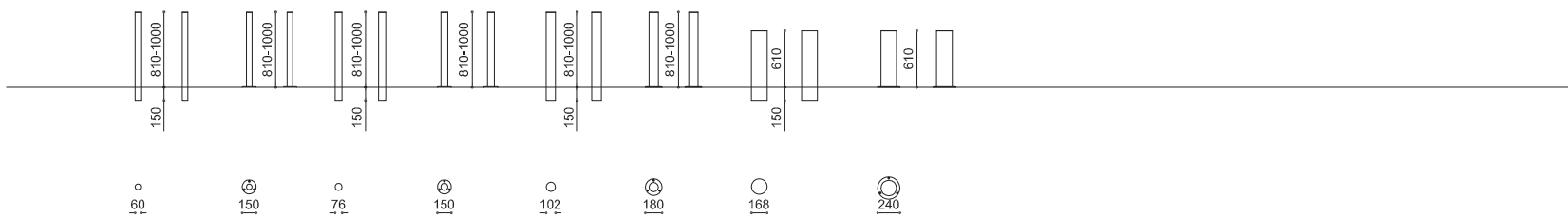

DIFFUSION NEWS

PIREO

EXPLOSION

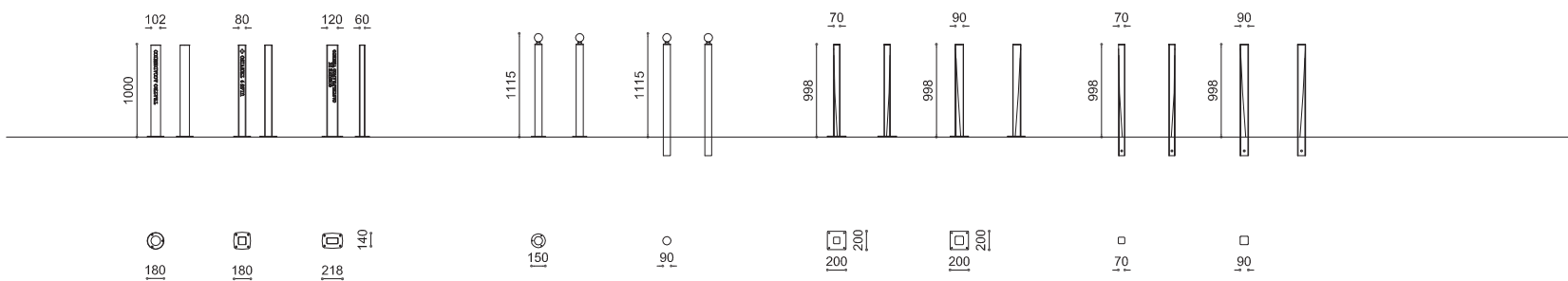

ZAFFIRO

CORALLO

SPRING D

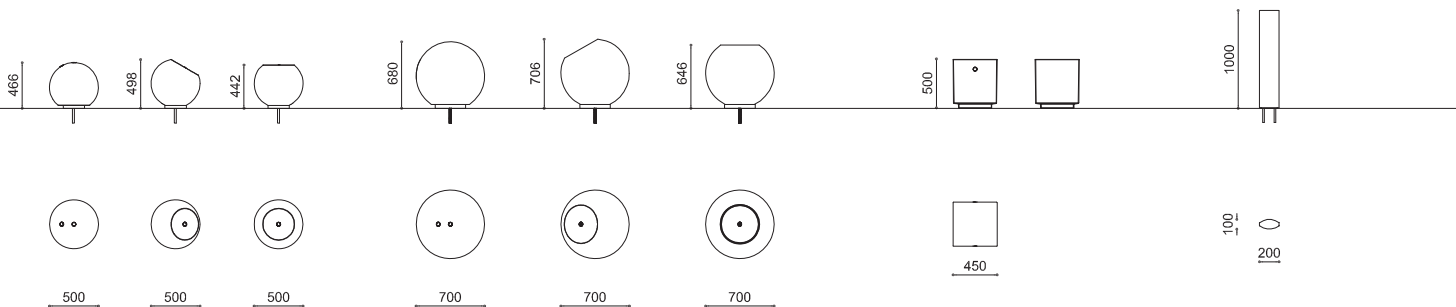

CUBE

HESPERIA

VISION

GENESIS

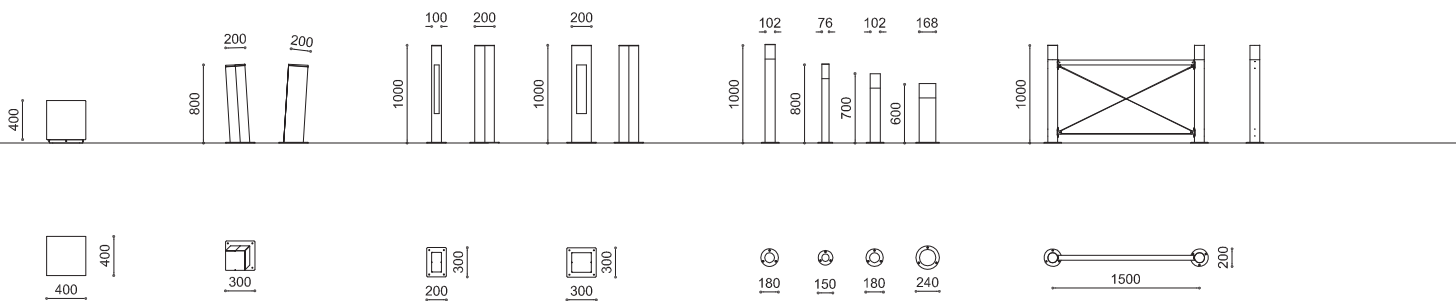

ROUTE

VERSO P

VERSO X

VERSO 240-490

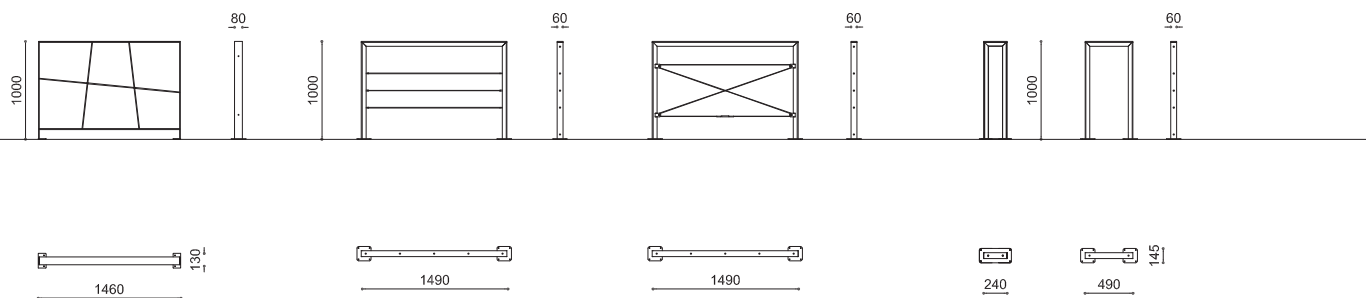

HARLEM

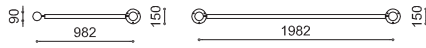
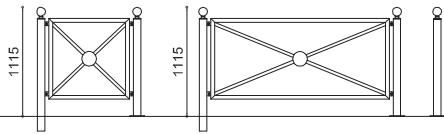

MASCHERA

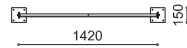
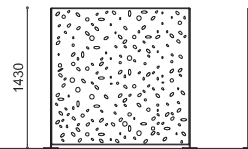

CROSS

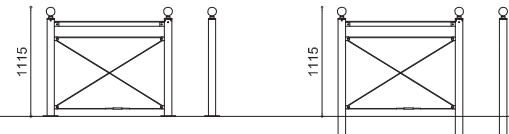

NEA

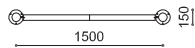
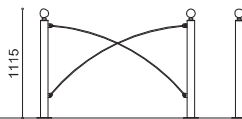

VOILA'

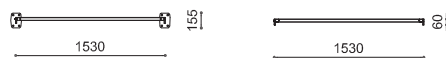
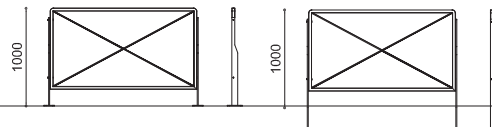

PENCIL

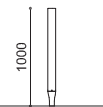

MAGIC

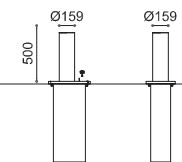

ICS

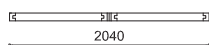
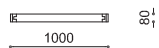
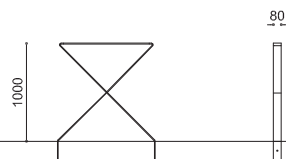

PALUS

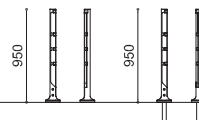

TRANSEO

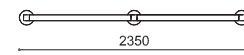
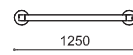
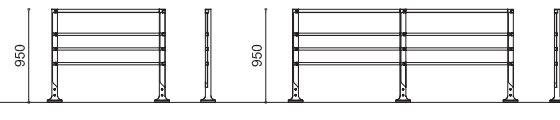

DELINEA

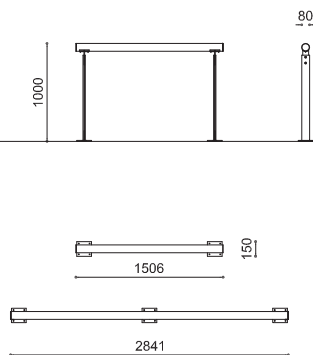

V-FORM 1M

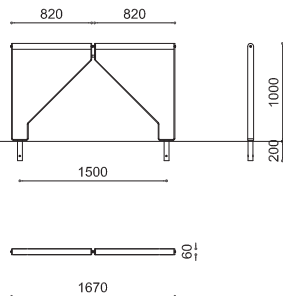

V-FORM 2M

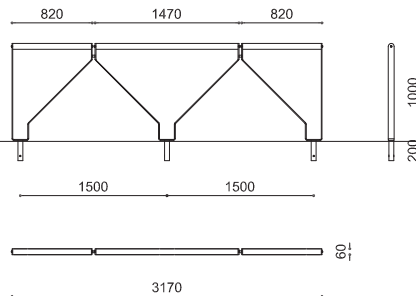

GITTER 1M

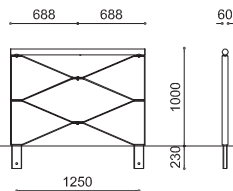

GITTER 2M

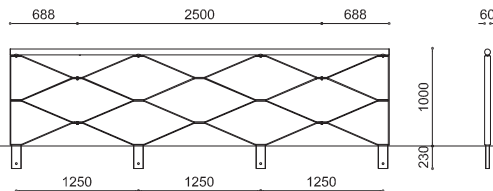

WORD

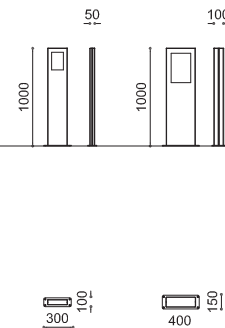

GALA

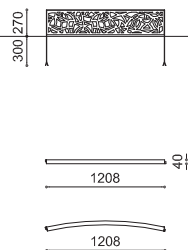

SPRING F

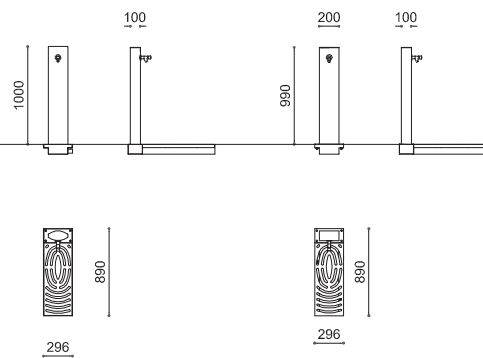

FUENTE

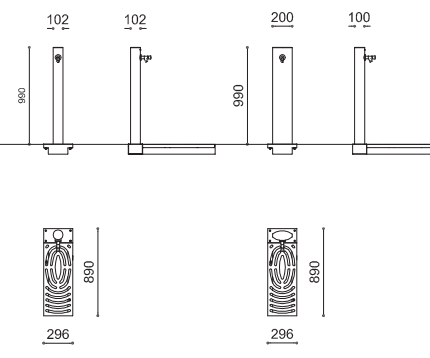

ALFA

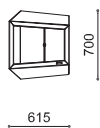
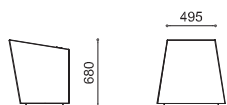

BETA

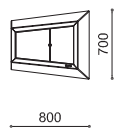

GAMMA

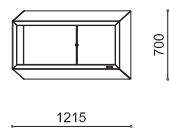
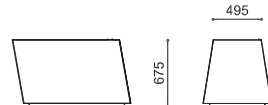

ALFA + BETA + GAMMA

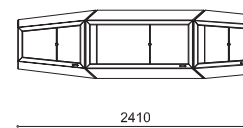

DAHLIA

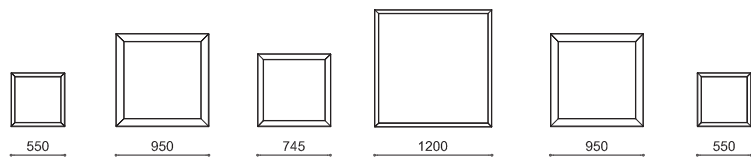
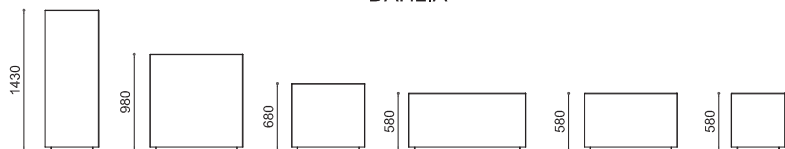

BAMBU'

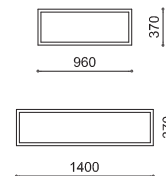

ASTER

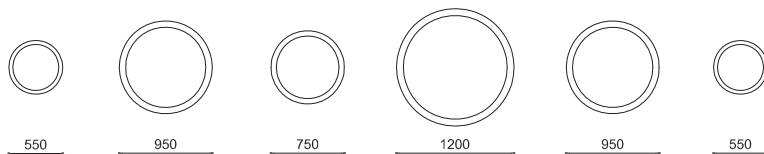
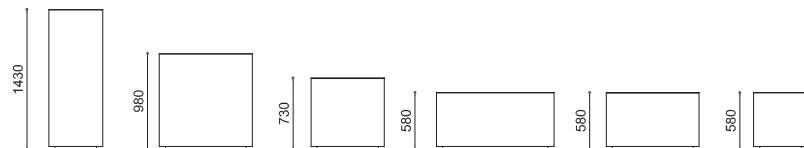

LOUNGE

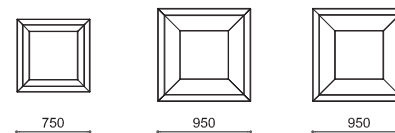
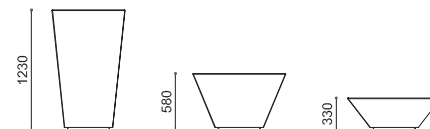

PITOCCA

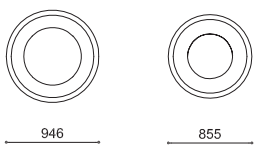

ECCENTRICA

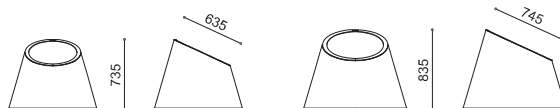

FLORES

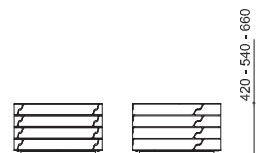

ONICE

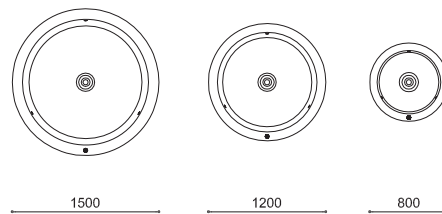
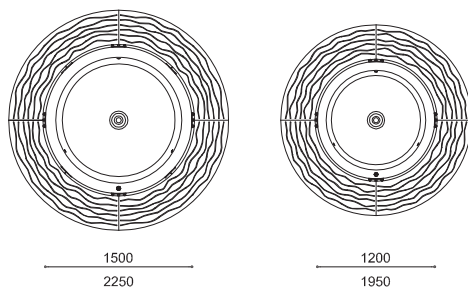

FLO'

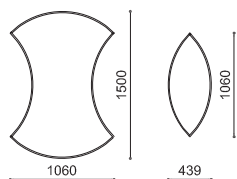

ELLI

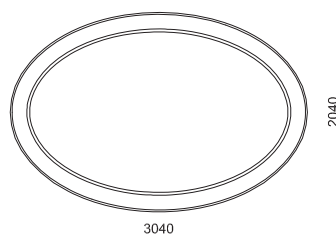
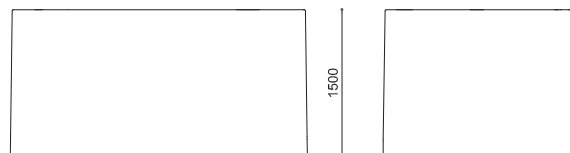

SIZE

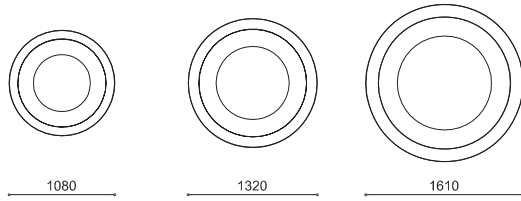
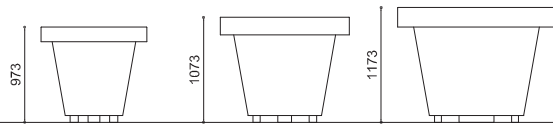

BALZAC

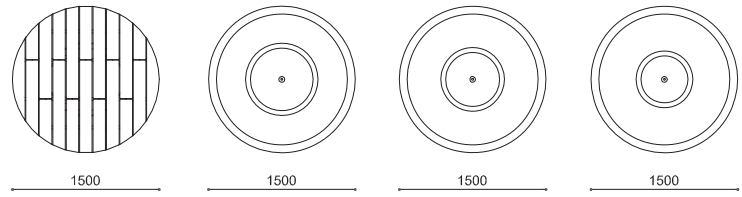
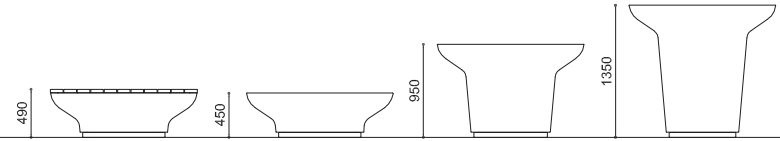

TRIANGLE

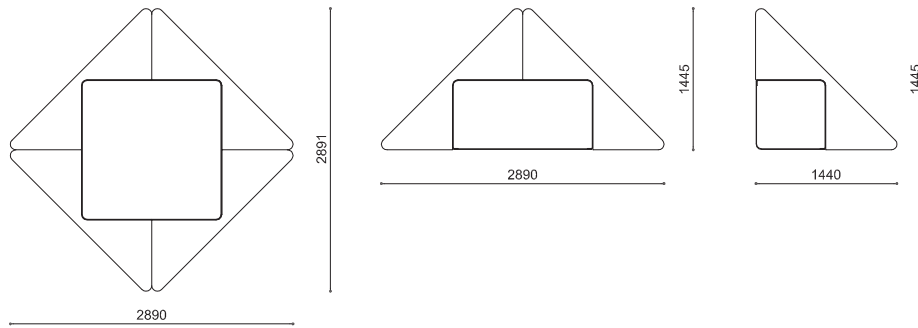
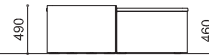

HELMUT

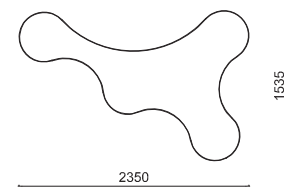

ARBORIS

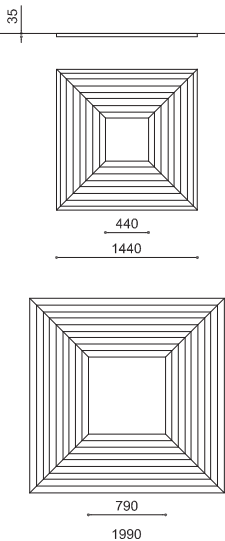

STELO

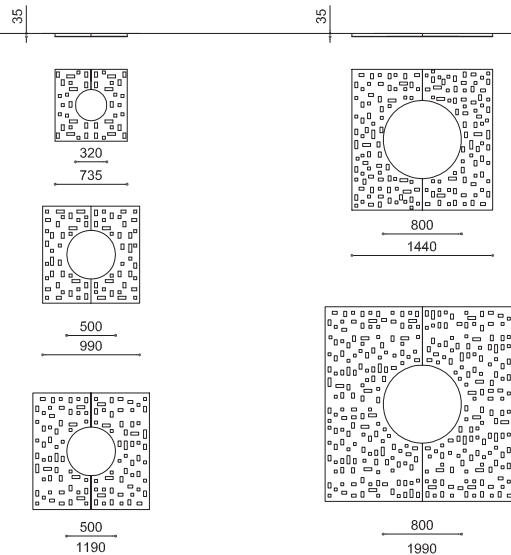

OBRA-Q

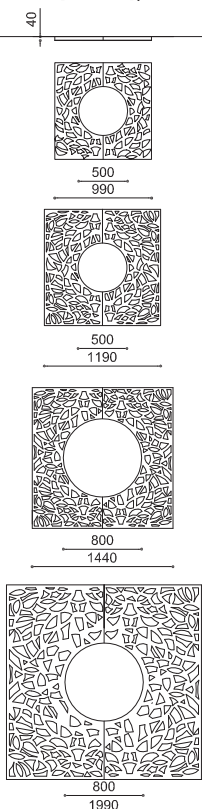

OBRA-R

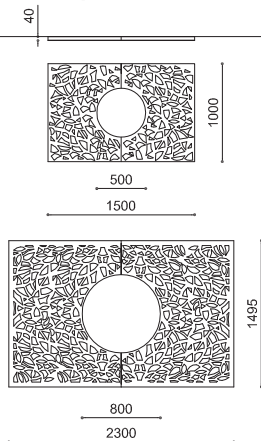

OBRA-C

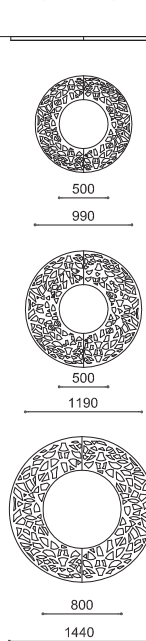

PERLA-C

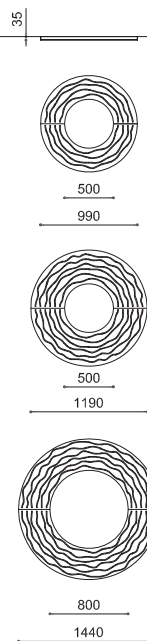

PERLA-Q

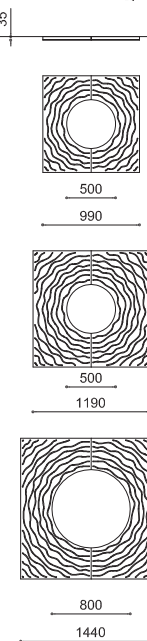

FLORA

LITTERA

35

35

35

35

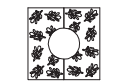

320
735

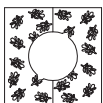

500
990

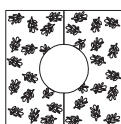

500
1190

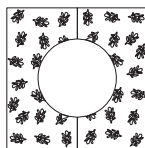

800
1440

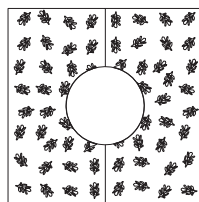

800
1990



320
735

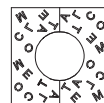

500
990

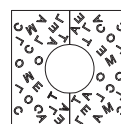

500
1190

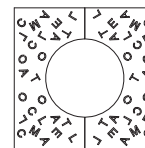

800
1440

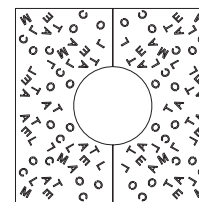

800
1990

SUNNY

TWISTER

CALIX

LAND

35

40

40

40

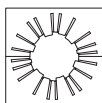

500
990

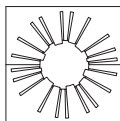

500
1190

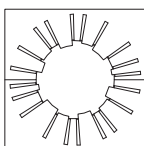

800
1440



500
990



500
1190

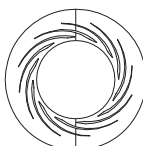

800
1440



500
990

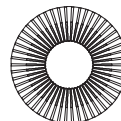

500
1190

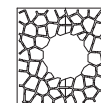

500
990

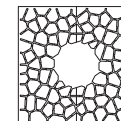

500
1190

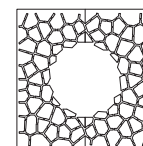

800
1400

ANNUNCI

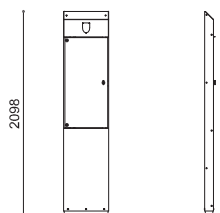

ATHOS

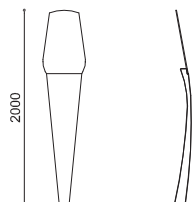

ICARO

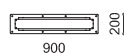
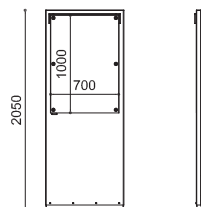

TARGA

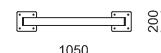
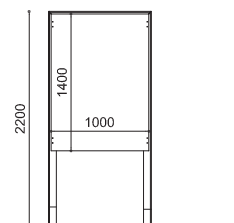

OMNIEXPO

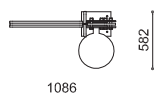
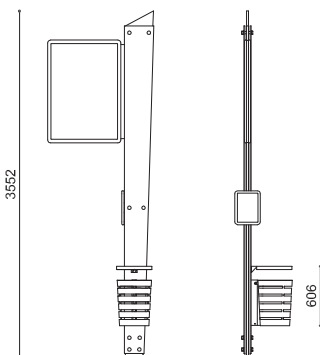

ASPEN

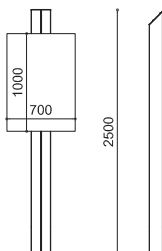

CHAMONIX

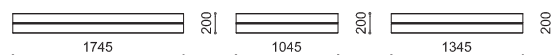
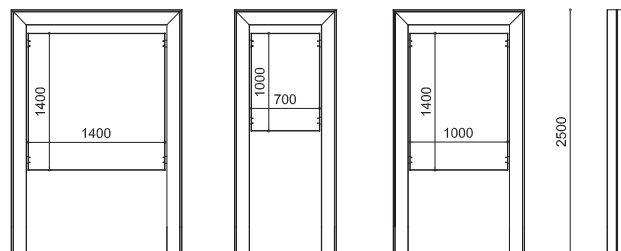

BACH

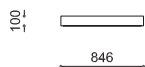
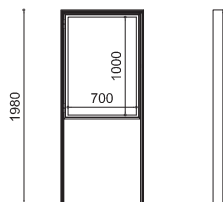

LEGGIO

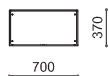
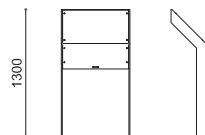

PARVUS

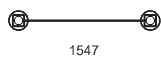
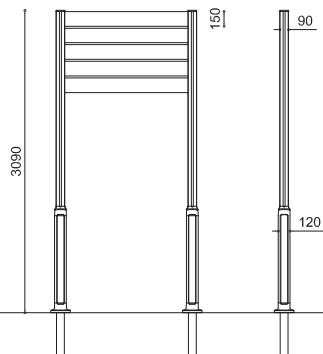

DUPLUS

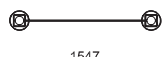
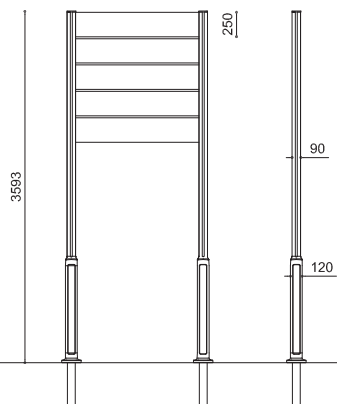

SINGULA

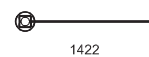
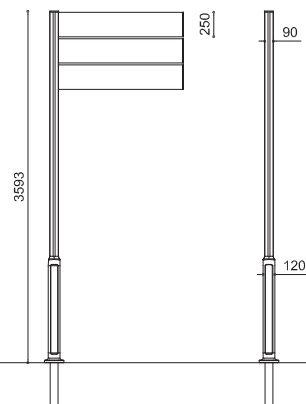

LATUS

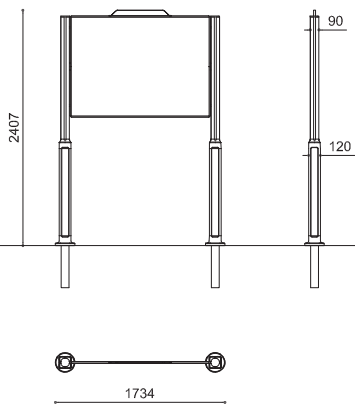

EXPO

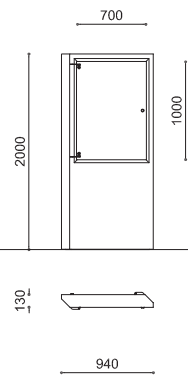

LANZAROTE

ALTUS

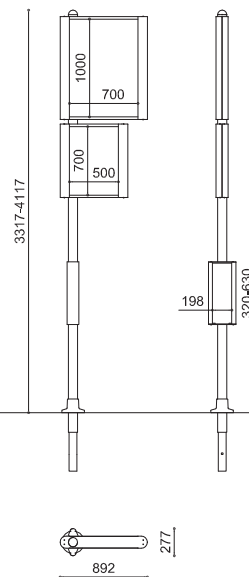
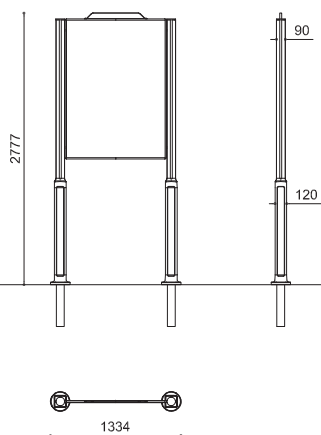

SENNA

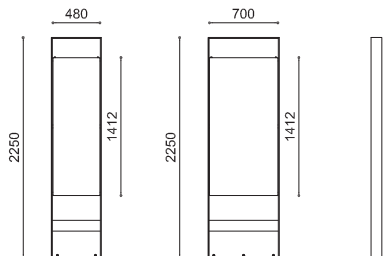

PEGASUS

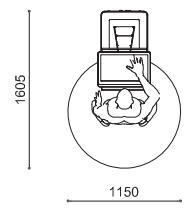

SIL

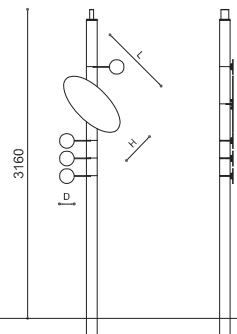
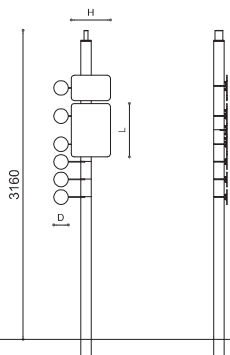

TED

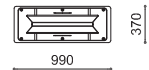
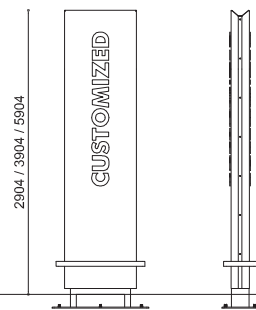

ATENA

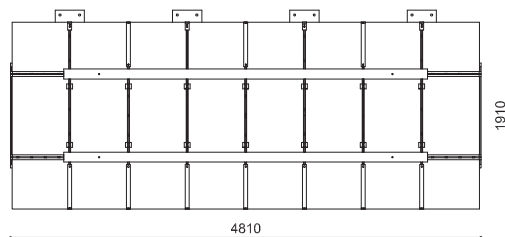
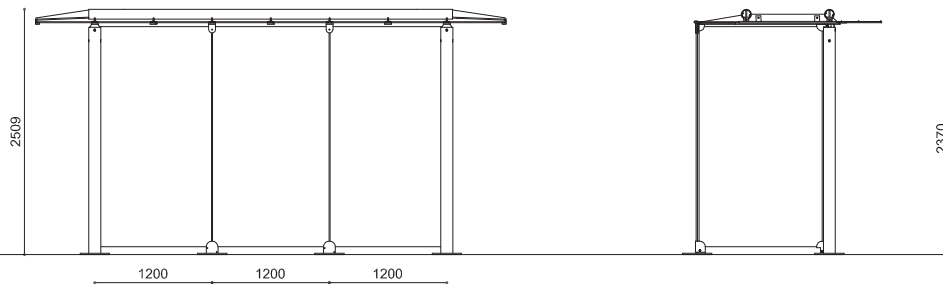

OMNIBUS

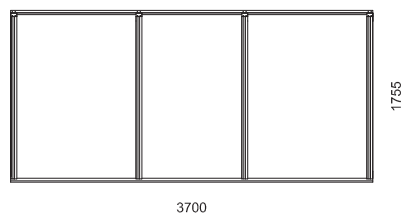
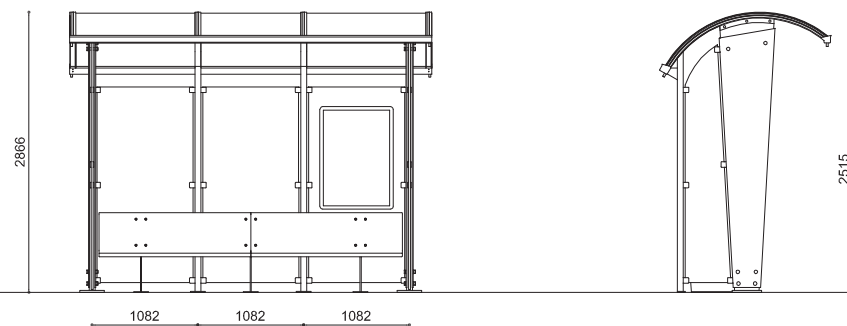

MERAK

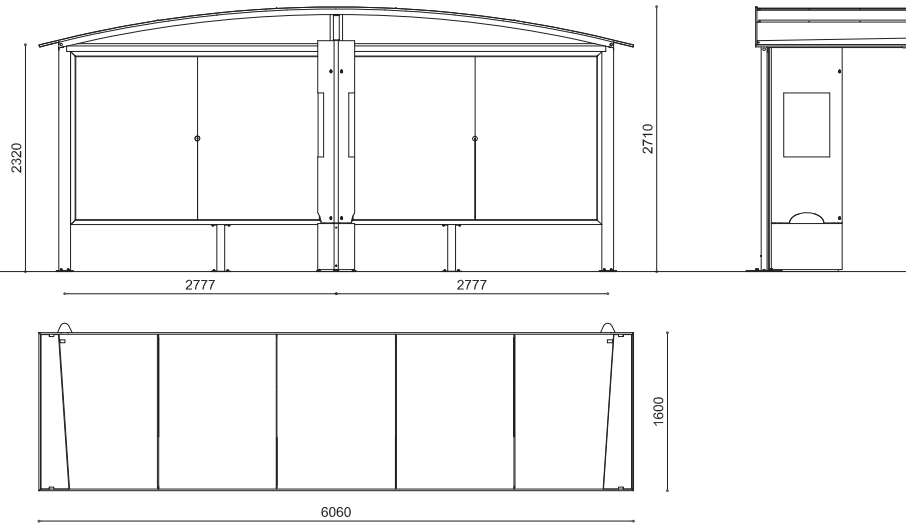

ALHENA

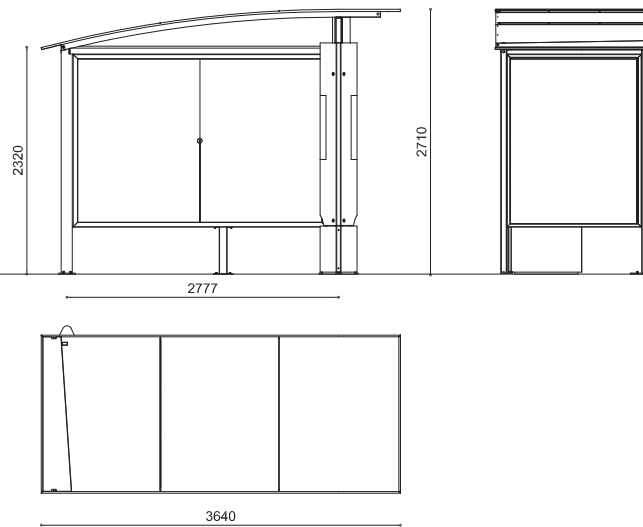

PARTNERS

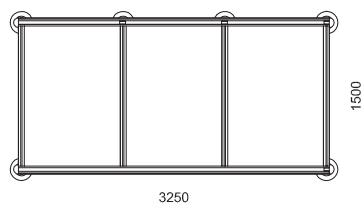
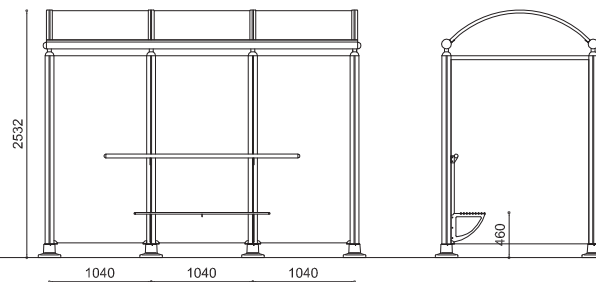

ARTS

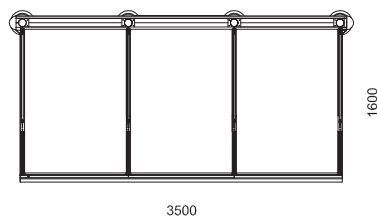
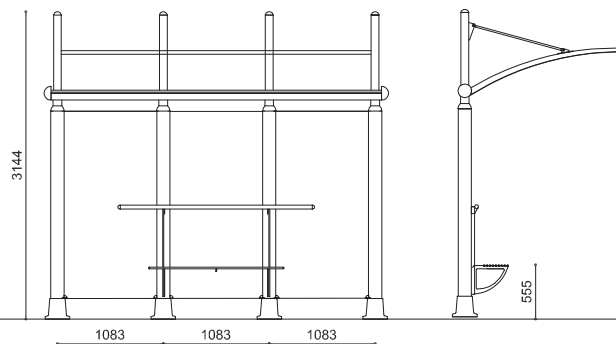

HUT

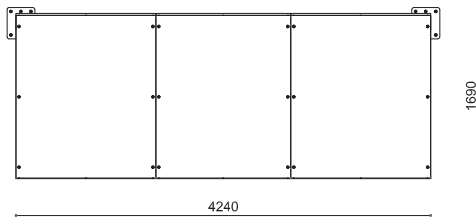
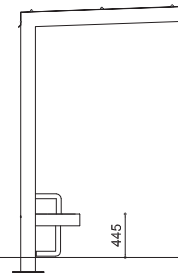
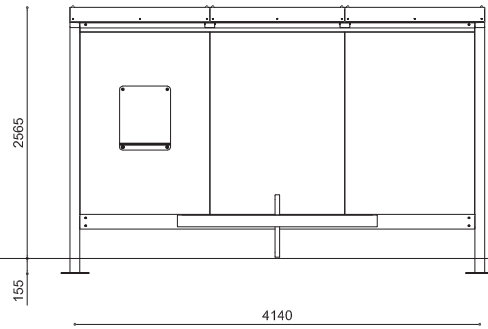
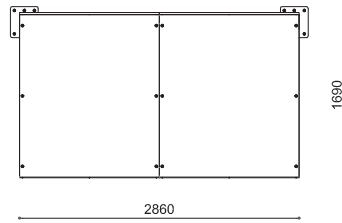
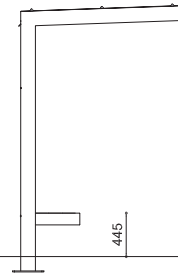
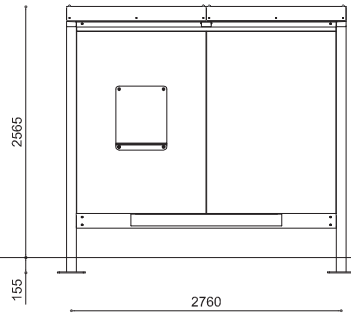

HUT

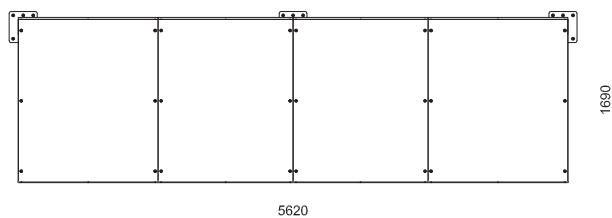
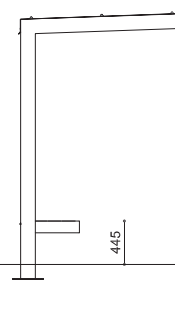
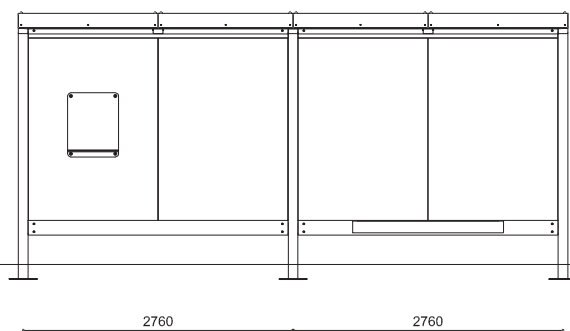
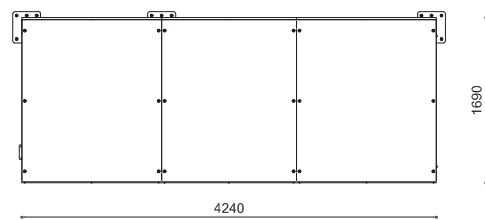
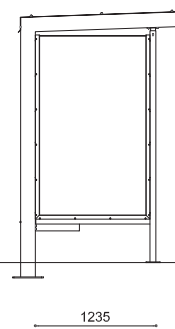
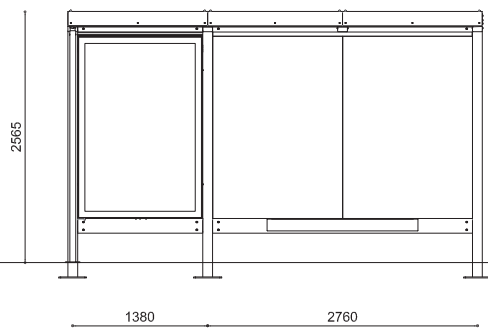

SPACE BICI

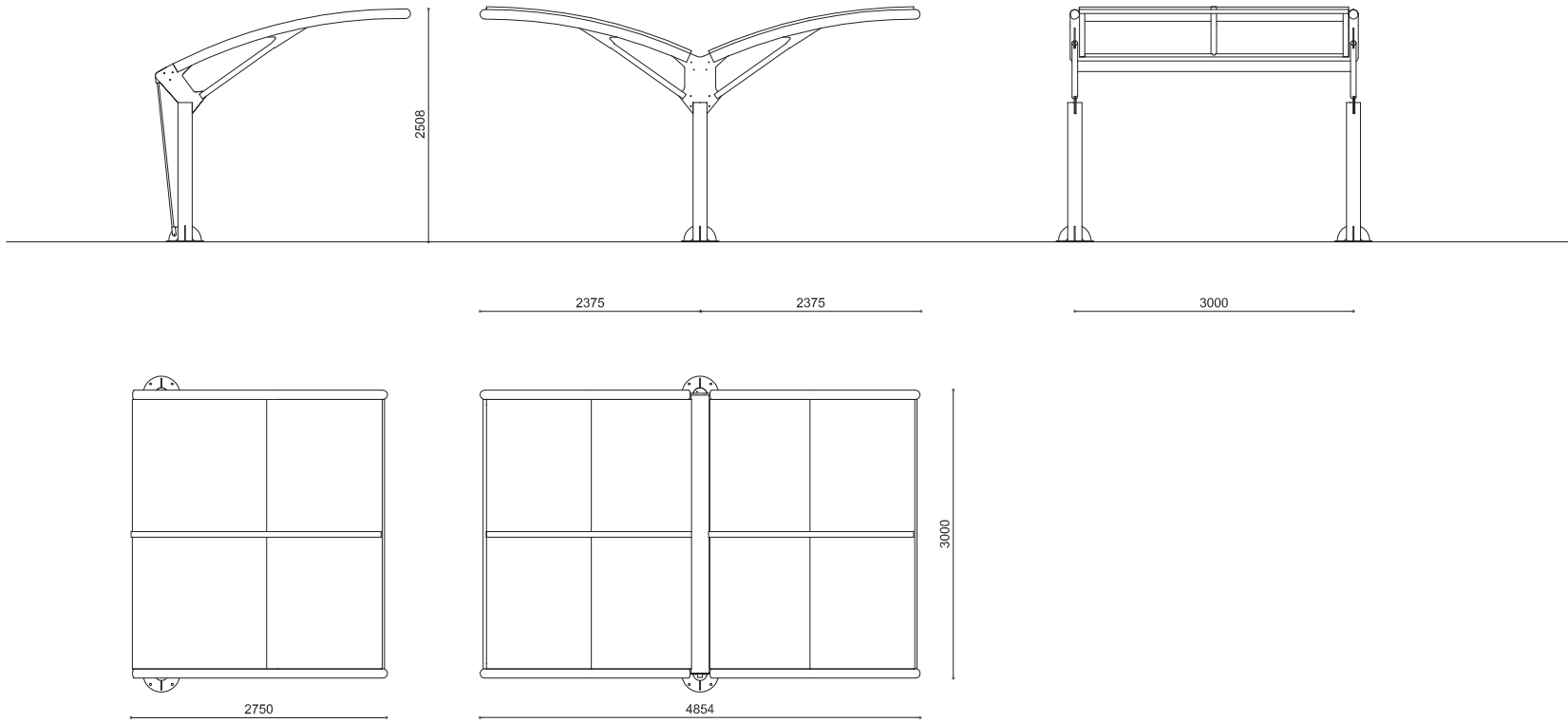

PENSILIS 1722

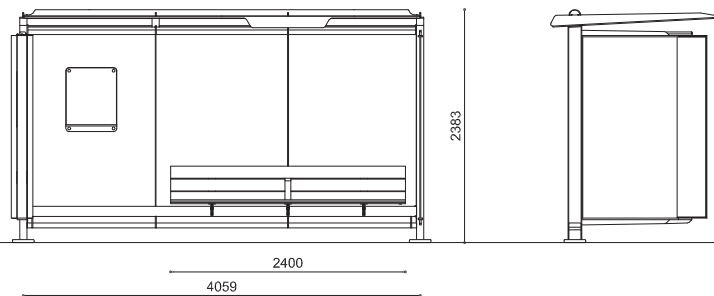

PENSILIS 1223

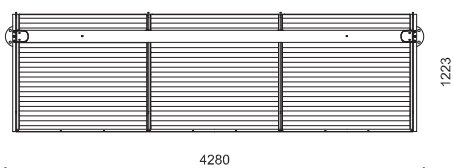
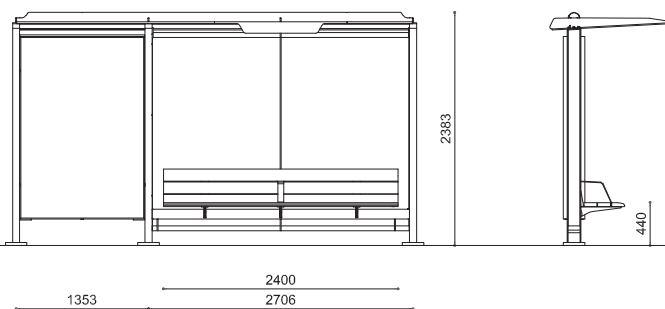

FOGLIA PICCOLA

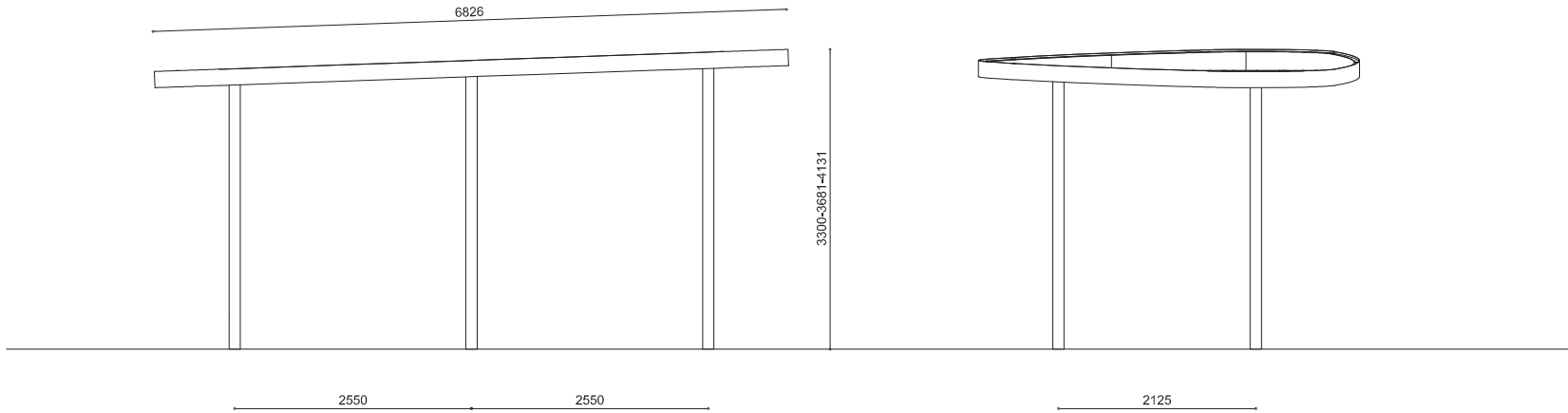

FOGLIA GRANDE

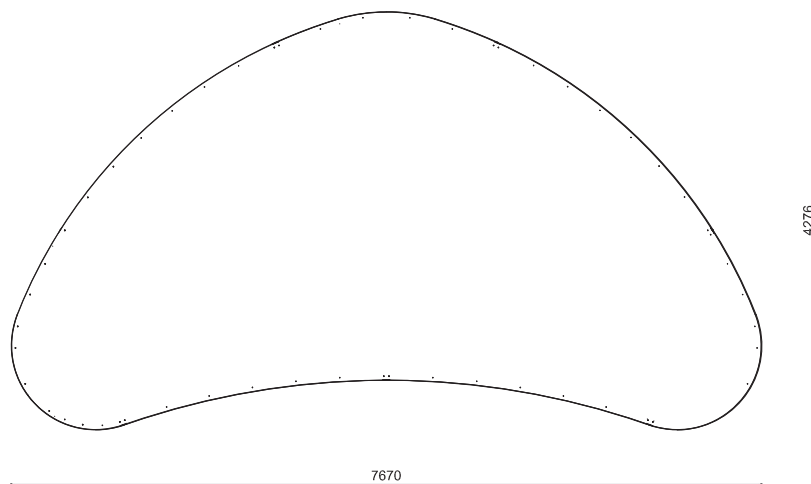
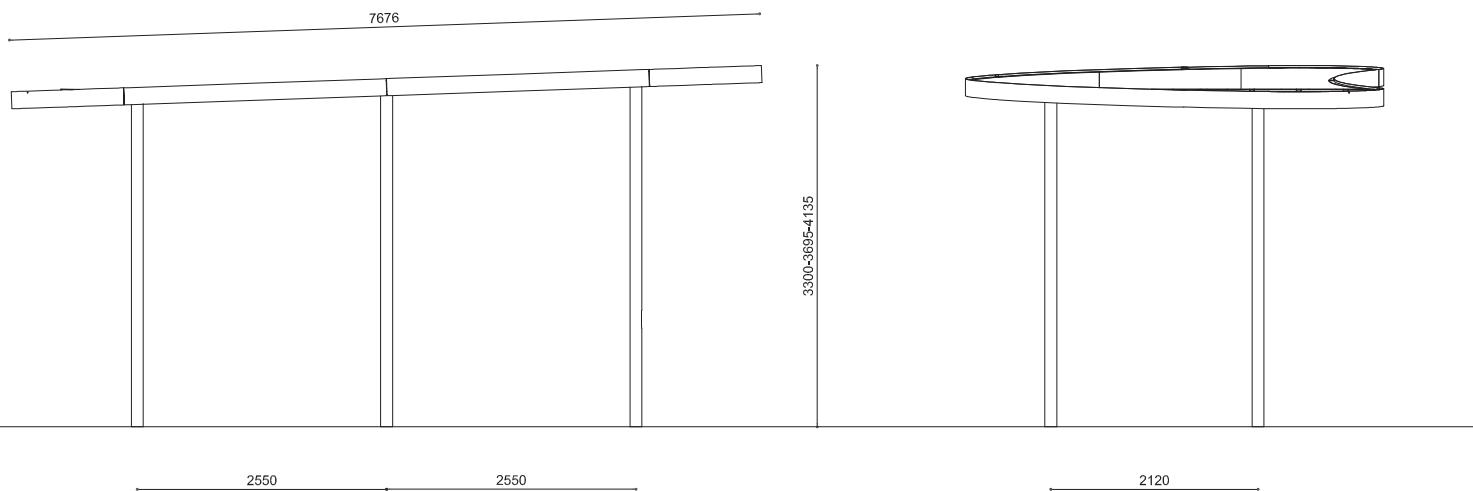

SPACE AUTO

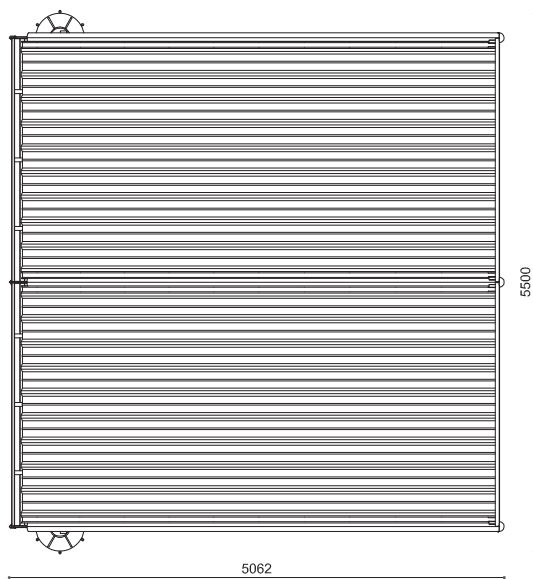
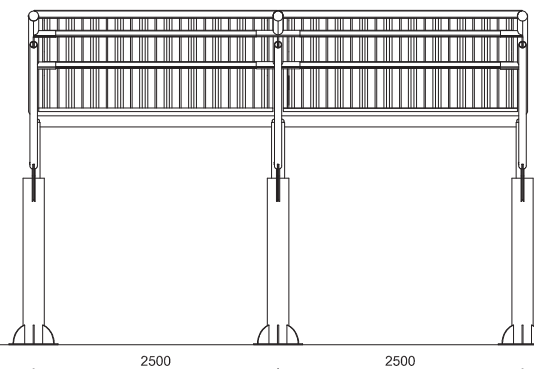
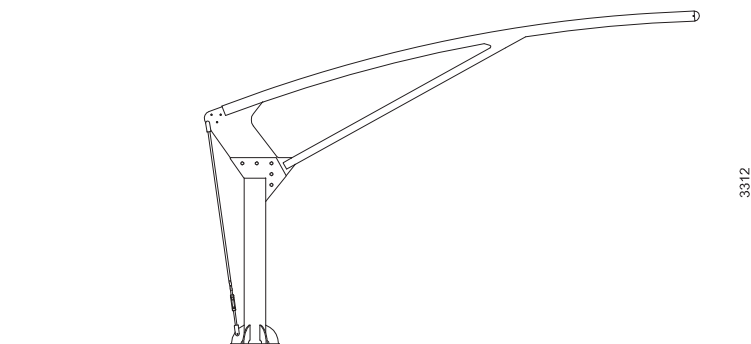

SMART CITY

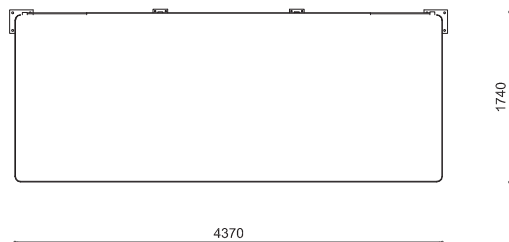
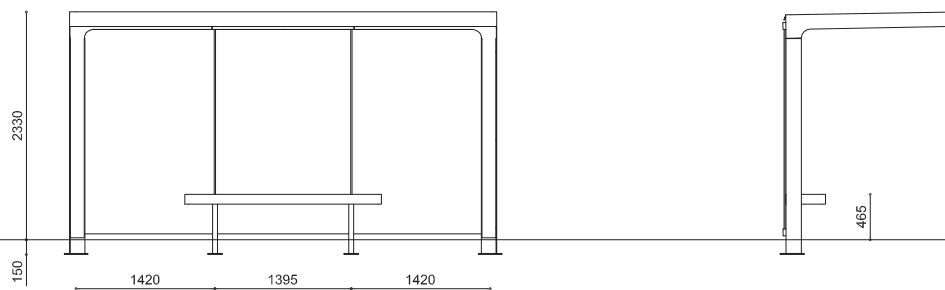

GPDUE

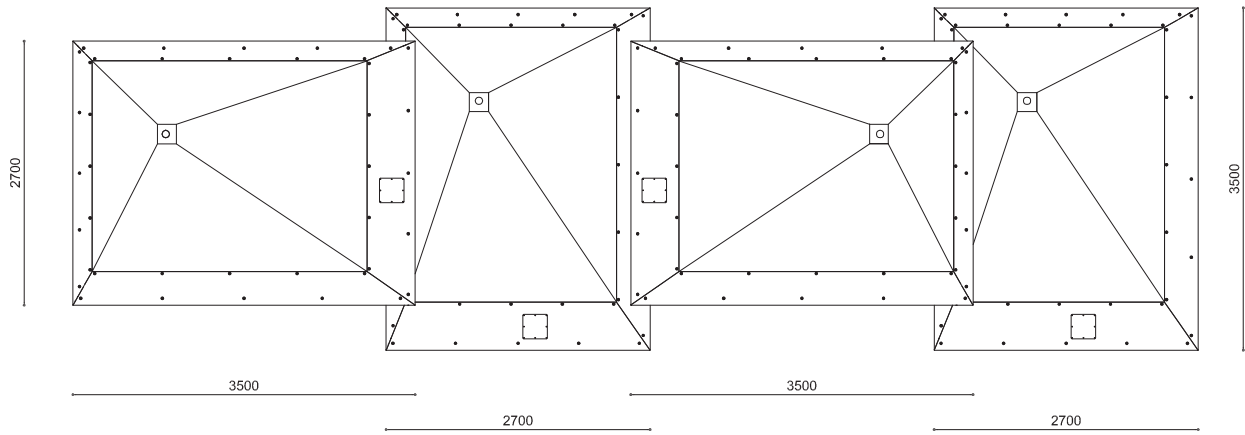
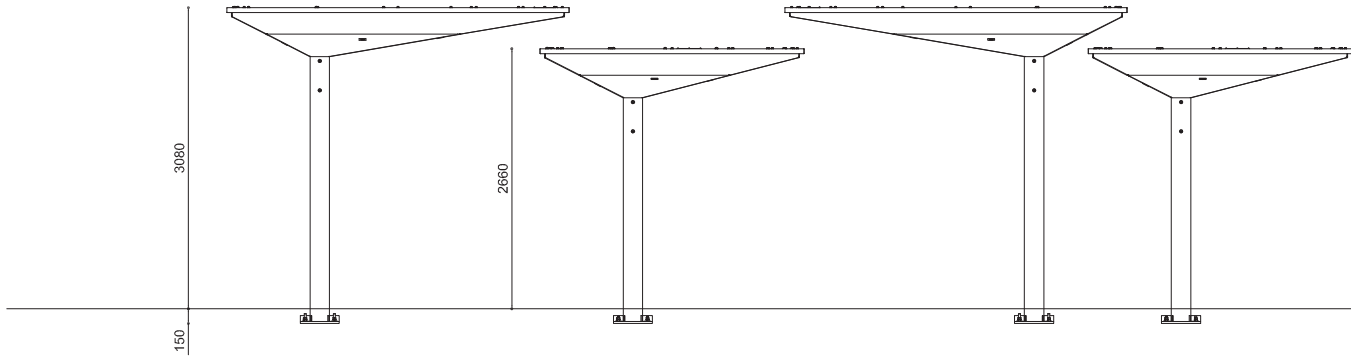

YPSILON

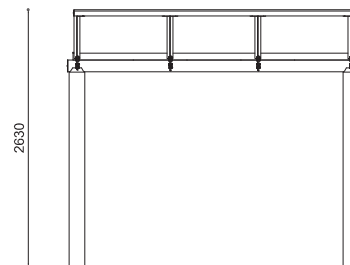
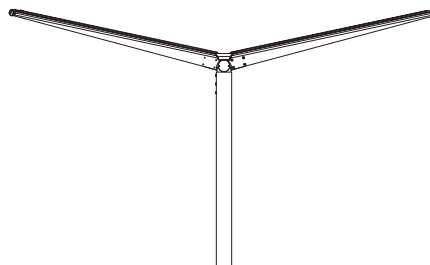

2800

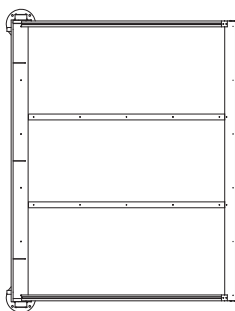

2299

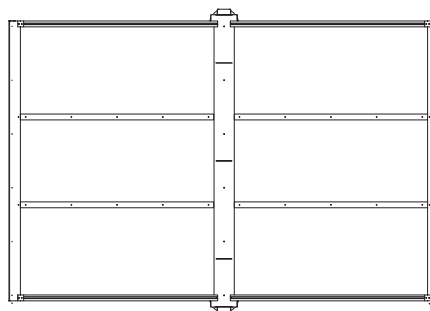

4397

SINTESI

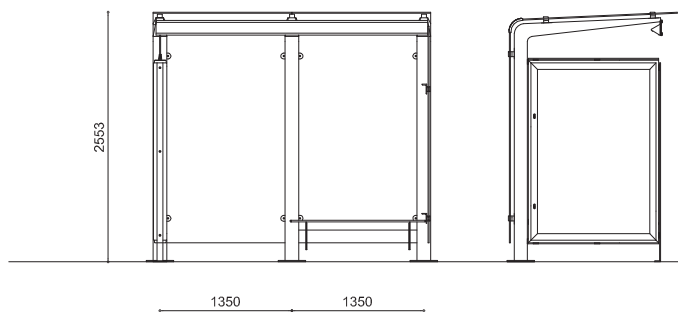

SELF

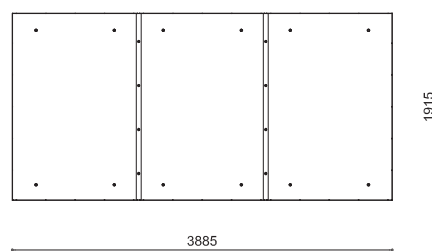
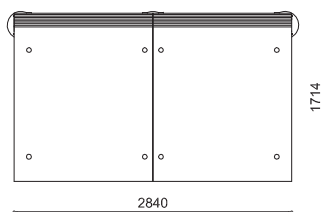
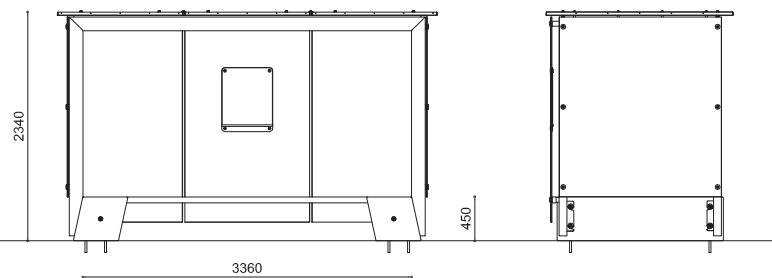

j 101



j 102

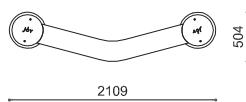

j 201

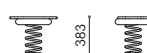

j 202

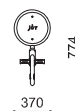
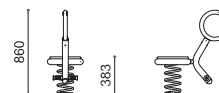

j 205

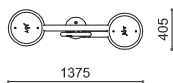

j 203

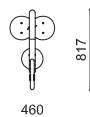
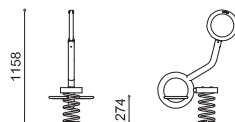

j 204

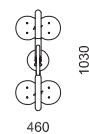
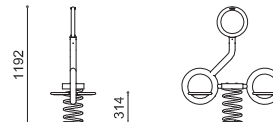

j 207

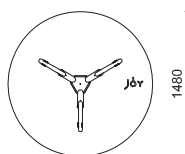
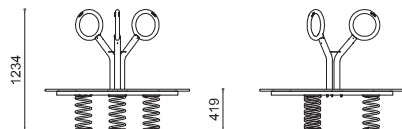

j 206

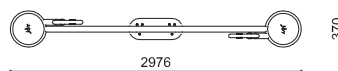
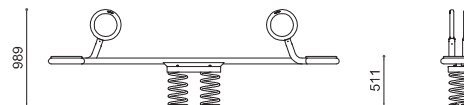

j 301

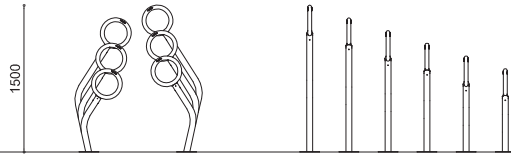

j 601

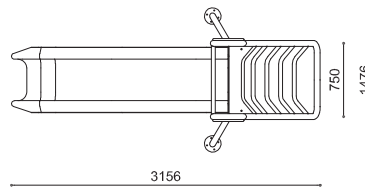
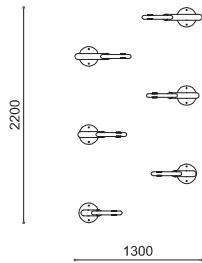
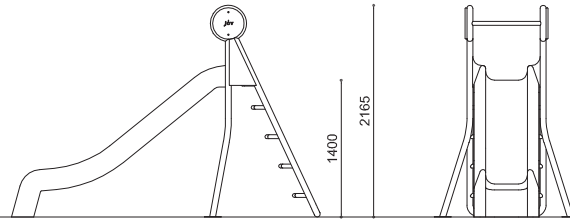

j 501

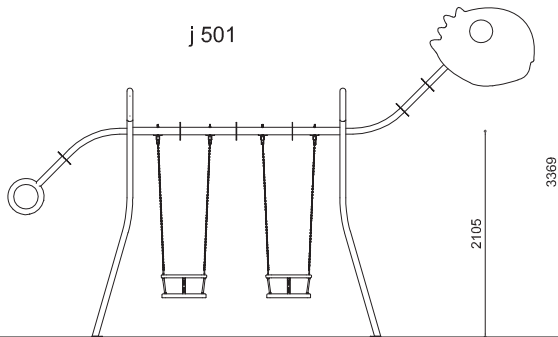

j 401

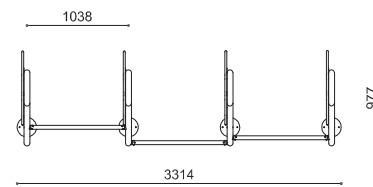
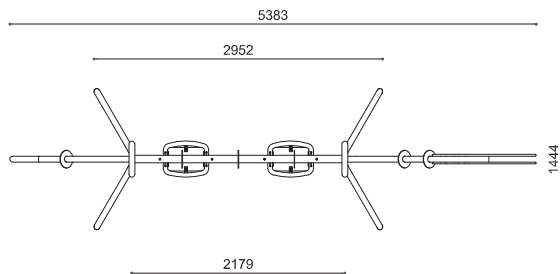
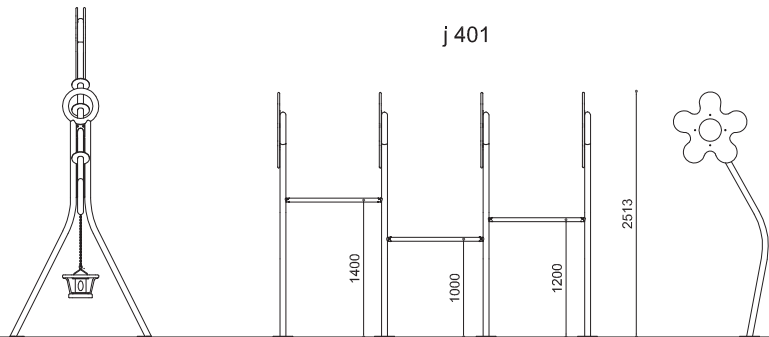

j 701

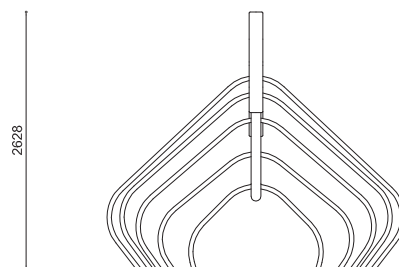
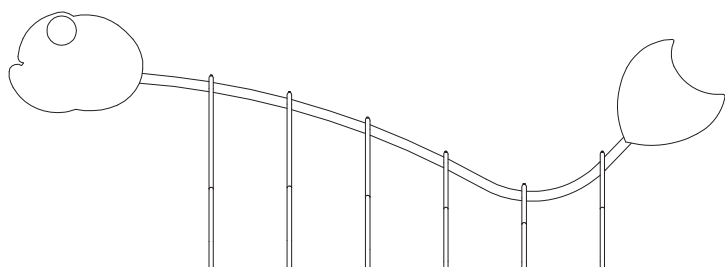

2628

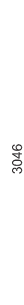
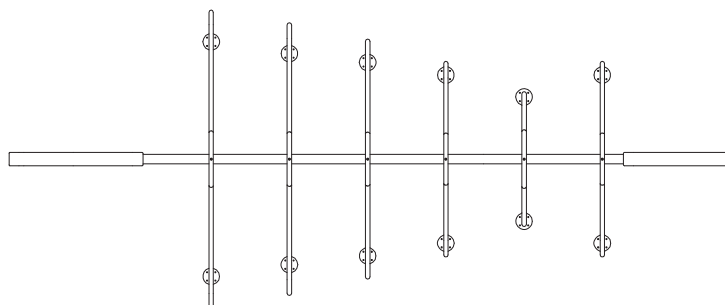

3046

7384

j 402

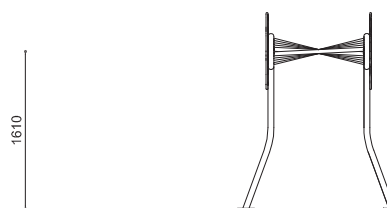
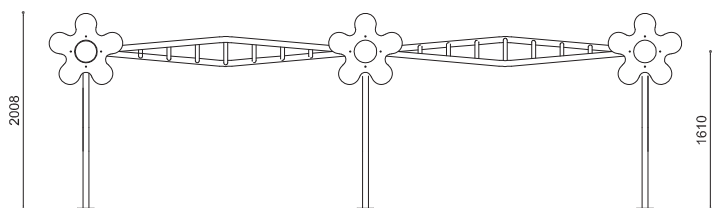

2008

1610

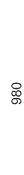
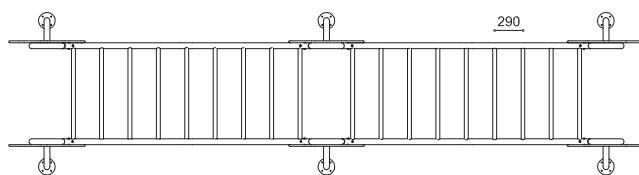

290

980

1661

6505

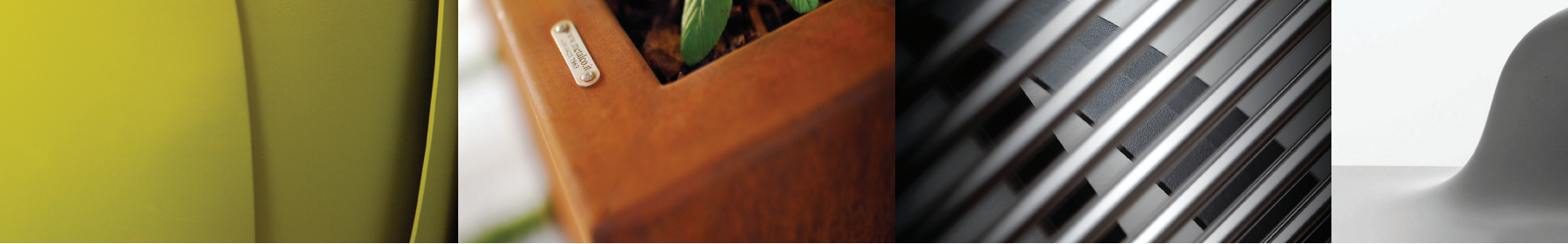

MATERIALS AND TREATMENTS



GENERAL REQUIREMENTS APPLICABLE TO ALL METALCO'S PRODUCTS IN ANY MATERIAL

Upon receipt of the goods, where it is not possible to place and/or install them within a few days, they must always be removed from plastic (nylon) packaging to allow ventilation and prevent the formation of condensation that can irreparably damage the product. Particularly, the packaging should always be removed immediately if it is not possible to keep the goods in a covered place protected from sunlight.

Warning: treatments and materials described in this catalogue are those in use on the same date of release of the catalogue. Metalco reserves the right to make changes and/or updates and/or improvements to treatments set forth herein to conform to its production needs and/or implementation of the quality of the final product. Metalco also reserves the right to delete and/or replace the materials displayed at their own discretion within the catalogue, as well as insert new materials. Any significant changes will be shown on the metalco website (www.metalco.it) and/or supplied by sales info or similar ways. The latest updated information on materials will be valid in all cases.



NOTES ON PRODUCTS IN PDM, HPC, UHPC

Slight color and finishing variations (micro-cracks, circle, oxide arising, shades differences and surface coat etc.) are natural phenomenon due to the production and maturation phase: no claims or requests can be raised for color variations connected to materials nature and to atmospheric conditions during production and maturation phase. In no case it shall be intended as nonconformity of the product.



ULTRA HIGH PERFORMANCE CONCRETE

I S E S

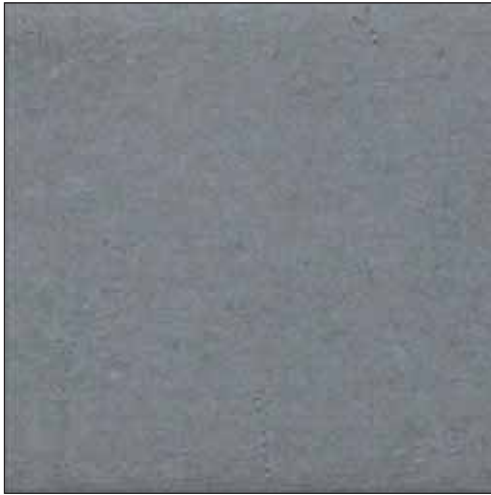

ALFA
Smooth surface finish



PSI
Textured surface finish



RECONSTITUTED STONES

I S E S

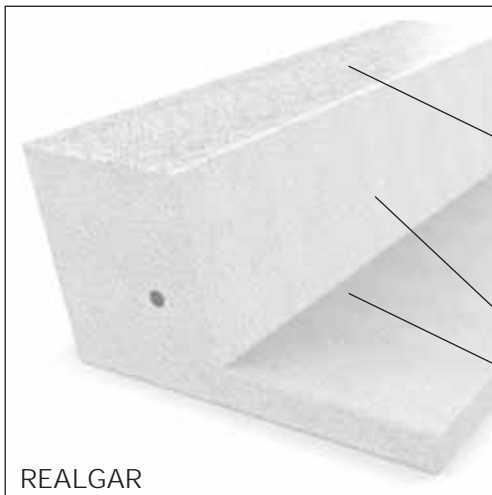

SMOOTH SURFACE

SANDBLASTED SURFACE

REALGAR

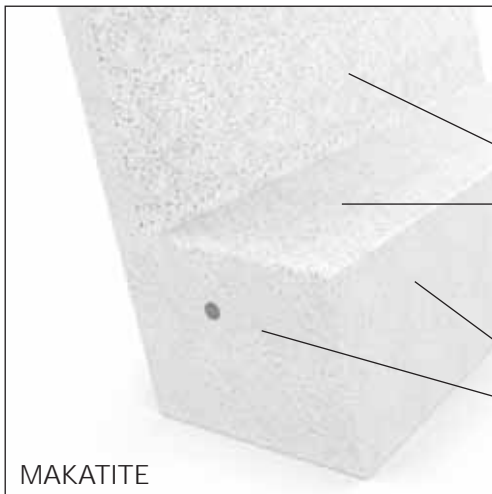

SMOOTH SURFACE

SANDBLASTED SURFACE

MAKATITE



MOONSTONE

MIX OF SANDBLASTED AND VELLUTO

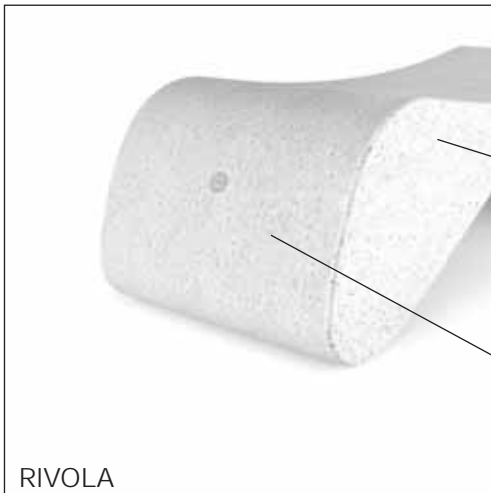

RIVOLA

SMOOTH SURFACE

SANDBLASTED SURFACE



TREE LINE - LORENZ

MIX OF SANDBLASTED AND VELLUTO



HIGH PERFORMANCE CONCRETE

I I S E S

DIAMANTE F

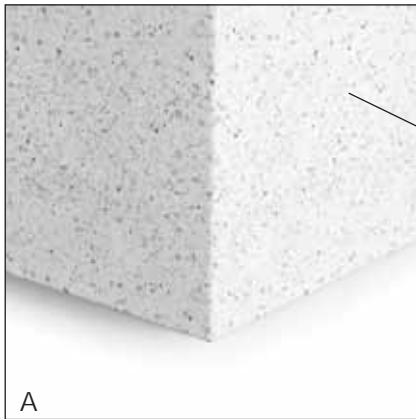

SMOOTH SURFACE

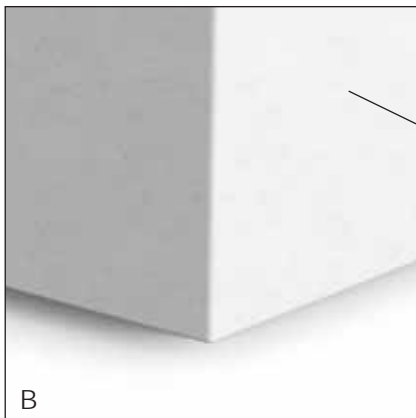

VELLUTO

DIAMANTE - AGATA - NATURAL PUZZLE - ISOLAURBANA

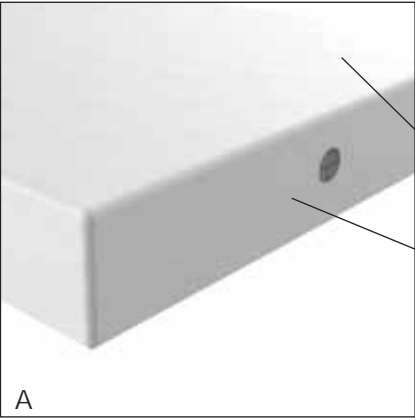

VELLUTO

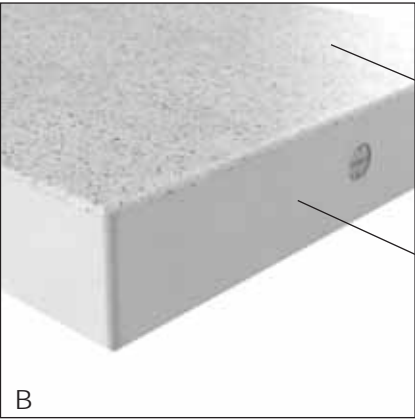

SMOOTH SURFACE

VELLUTO

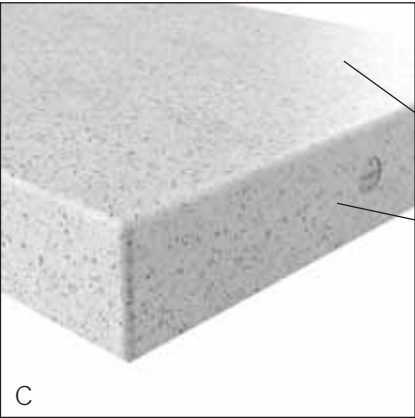

SMOOTH SURFACE



POWDER COATED STEEL / POWDER COATED ALUMINIUM

GALVANIZATION ON STEEL

For coated steel products, Metalco alternatively uses three galvanizing systems:

- hot-dip galvanizing
- sendzimir galvanization
- cold galvanization

Metalco selects, each time, the galvanizing system most suitable for the thickness and/or shape and/or manufacturing process of each article.

COATING ON STEEL AND ALUMINIUM

1. Preparation
(sandblasting automatic or manual sanding)
2. Alkaline degreasing
3. Rinsing with water system
4. Rinsing with demineralized water
6. Drying with hot air 160°C
7. Application of epoxy primer zinc*
8. Polymerization in the oven 185°C*
9. Cooling*
10. Application of electrostatic pure powder polyester
11. Polymerization in the oven 185°C
12. Cooling
13. Final test

(*) only on request and/or on cast iron components

Warning: Please remember that not all steel coated products are recommended for placing in areas where there is salty air (e.g. near the sea) or heavy air pollution. This treatment improves the corrosion resistance of coated steel. The treatment is subject to additional charge. Please contact the Metalco Sales Office for more information or advice.

Maintenance. Painted surfaces which become scratched can be restored, by using the colour touch-up sprays. 400ml cans of Metalco's standard RAL are available upon request. The colour should be sprayed from a distance of 10-20 cm onto the surface which has been previously cleaned from dust and dirt. Drying is achieved in about 15 minutes. For colours not included in our standard chart, touch-up liquid colour can be requested. If however, on steel products, damage is deep and breaks the zinc protective coating below the paint, it will be necessary to proceed with an application of a zinc spray between the phase of cleaning and repainting. Metalco can, upon request, provide an aerosol for retouching the zinc coating.

In case of any doubt about the proper maintenance procedure, please contact the Metalco office for advice.

COLOURS

O

Wrinkled finish



Sablé finish (subject to price surcharge).

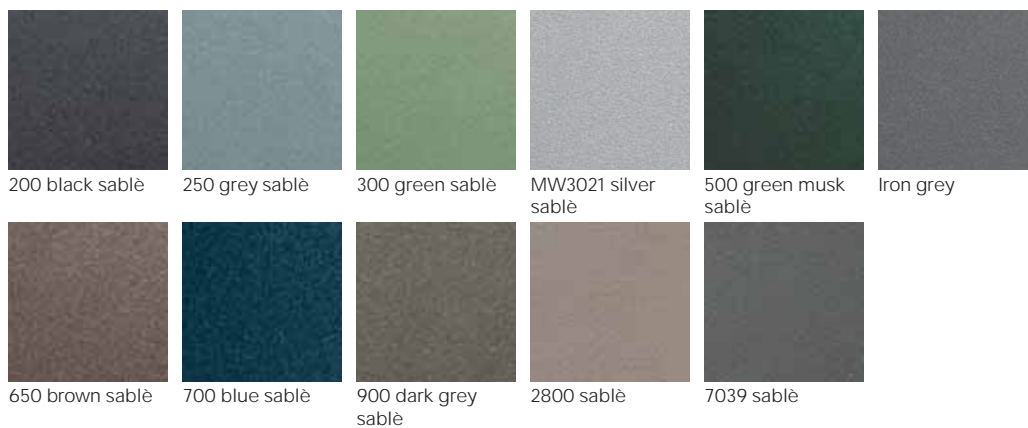

The reproduction of colours in the brochure are not a true RAL match.



CORTEN STEEL

FEATURES AND CYCLE OF AGING METALCO CORTEN

In order to initiate corten steel maturation process, Metalco uses an oxidation process through weathering. This type of system is based on the fact that in such areas patina process is slower.

Shades of colors, indeed, are not a defect.

Corten steel, thanks to the process of maturation/oxidation that characterizes it, is considered a "live" material, which may vary over time, in shades and hues, depending on the shape of the object, the position in which it is installed and according to the cycles of weathering which the object undergoes.

Warning: the average period of "stabilization" of corten maturation process, giving to the material a "testa di moro" ("brown") color typical of the oxidized corten, is approximately 12/18 months with adequate weathering.

During maturation process, corten may leak oxide ("wash-out"), which may stain surfaces where products are located: this shall be considered natural and physiological behavior of the material.

To reduce wash-out above, Metalco has developed a specific treatment "ANTI-WASHOUT" the client may request, an extra-cost will be applied: this treatment does not completely stop the losses, but they will be significantly decreased, and will provide to the product a darker and "refinished" aspect.

For the reasons above, the installation of corten products on fine and/or porous surfaces (e.g. marble, granites, etc.) must be accurately considered, even in case of Anti-washout treatment: in such events it may be recommendable to use, as alternative, the painted steel "corten colored" developed by Metalco.

Also, in the vicinity of the sea, the violent assault of salty air can lead to the formation of oxides on the surfaces that result in the appearance/colour looking different to normal. This does not affect good mechanical strength of the material.

Maintenance.

Minor surface defects (smears, dents, stains) may be repaired. If corten is natural, without Anti-washout, rub down the surface with steel wool (as Scotch Brite) until the defect is eliminated. Then, moisten with water and place the product on the outside, until the part returns to have the surface characteristics of the rest of the piece.

If corten is treated with Anti-washout treatment, repeat the above process, previously removing the treatment deposits with steel wool. After this area is re-oxidized after the exposure to weathering, re-apply with brush two coats of Anti-washout treatment (purchasable from Metalco). If Anti-washout treatment degrades, due to weather or mechanical agents, it is possible to re-treat the product accordingly to the procedure above (deposits removing - oxidation - treatment re application).

For any doubt on correct maintenance procedure, please consult Metalco Quality Office.



1. Appearance/shades of oxidized product at the time of delivery (approximately 2 months of oxidation).



2. Appearance/shades of oxidized product after approximately 4/6 months from its installation.



3. Appearance/shades of the product at the end of the period of oxidation after about 12/18 months of installation.



4. Corten steel with "Anti-washout" Metalco special treatment

N.B.: Shades images on paper are merely illustrative. Upon request physical sample will be provided.



STAINLESS STEEL

Metalco normally uses stainless steel AISI 304 or 304L.

S

1. Satinizing
2. Shot peening (on small products and/or accessories)

On request, subject to extra-charges, electropolishing treatment can be provided.

Warning:

In case of installation of stainless steel products in areas characterized by salty air (e.g. near the sea) or by severe pollution, Metalco recommends to request ELECTROPOLISHING treatment.

This treatment improves stainless steel resistance to corrosion. This treatment is subject to extra-charges.

Maintenance.

Metalco recommends to periodically clean stainless steel products to eliminate salt, dust and other deposits which may alter the protective layer of the material. Washing, as well as making the product clean, reduces the risk of corrosion. Normally it's all- purpose cleaner with a soft cloth; while in case of thicker deposits, very hot water with 1/4 of vinegar is necessary. For grease

For any doubt on proper maintenance procedure, please contact Metalco Quality Department.



A mixture of binders and granite or marble aggregates, accurately washed and controlled, with good technical and structural marble).

A

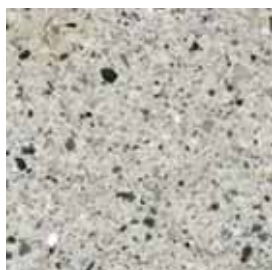

polished surface with granite aggregates



sandblasted surface with granite aggregates



polished surface with black marble aggregates

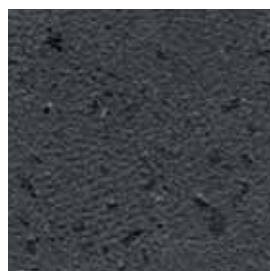

sandblasted surface with black marble surface



polished surface with white marble aggregate



sandblasted surface with white aggregate

KEY FEATURES OF PDM PRODUCTS

Generally seating and horizontal surfaces are polished, while all other vertical surfaces are sandblasted. Upon

I

product, please consult the section dedicated to the product or see our web-site.

S

which increase the products' life and resistance characteristics to rain erosion and to mold and similar events.

"ANTIGRAFFITI" treatments.

Generally PDM products come with bushings embedded in the stone for lifting them during the installation phase.

Maintenance.

Wash the material with water and mild detergent, to avoid dirt and weathering deterioration. It is possible to repair small

of product.

For any doubt on correct maintenance procedure, please consult Metalco Quality Office.

N.B.: The images reproduced in these pages are merely indicative; please refer to physical samples.



HIGH PERFORMANCE CONCRETE

Mixture of reinforced performing concrete, with granite or marble aggregates, with a good technical and structural
A

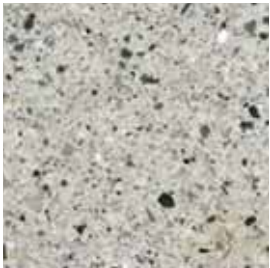

HPC with polished granite



HPC with granite VELLUTO

KEY FEATURES OF HPC PRODUCTS

VELLUTO SURFACE AND SIDES
POLISHED SURFACE AND VELLUTO SIDES

available on each product, please see the section dedicated to each
S
which increase products' life and resistance characteristics to rain erosion and to mold and similar events.

Upon request, with extra-charge, it is possible to request "ANTIGRAFFITI" treatment or, alternatively, WAX TREATMENT.

Generally HPC products come with bushings embedded in the stone for lifting them during the installation phase.

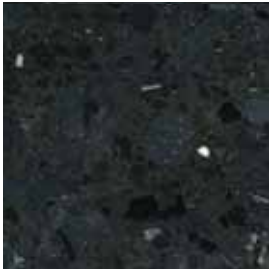

HPC with polished black marble



HPC with black marble VELLUTO

Maintenance.

Wash the material with water and mild detergent, to avoid dirt and
I
kits to be ordered according to the type of product.

In case of any doubt about the proper maintenance procedure, please contact the Metalco Quality Department for advice.

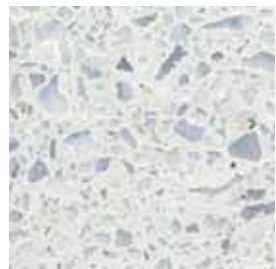

HPC with polished white marble

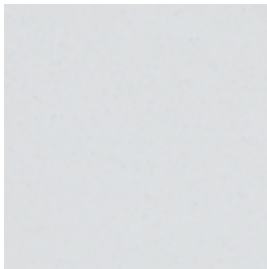

HPC with white marble VELLUTO

N.B.: The images reproduced in these pages are merely indicative; please refer to physical samples.

combined with extraordinary freedom of design.

Available on following colors:

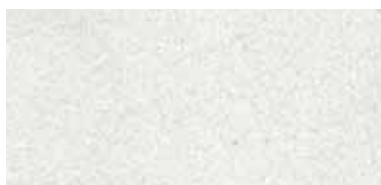

101B



503



303



105Y

KEY FEATURES OF UHPC PRODUCTS

ALFA:

PSI:

product page.

S

increase the products' life and resistance characteristics to rain washout and to mold and similar events.

A I RA I I

treatment or, alternatively, WAX TREATMENT.

Products of higher weight are generally equipped with bushings embedded in the mixture for mounting handling and installation eyebolts.

Maintenance.

Clean the material with water and mild detergent, to avoid build up of dirt and weathering. For small chips of the material is possible to make the repairs with the appropriate kit to be ordered according to the type of

In case of any doubt about the proper maintenance procedure, please contact the Metalco Quality Department for advice.

N.B.: The images reproduced in these pages are merely indicative; please refer to physical samples.



WOOD

METALCO IS CERTIFIED FSC C003657

D

A

of this is natural.

STANDARD METALCO TYPES OF WOOD

A. EXOTIC WOODS

Angelim Amargoso, Iroko, Movingui, Basralocus.

Metalco selects, from time to time, the exotic wood which better suit to the product and/or to the project according to the availability on the market.

O
E _____ S _____

B. LARCH WOOD

Metalco always provides larch FSC.

L _____ O _____

C. OKUME'

I _____

D. OKUME PLYWOOD

It is always and exclusively supplied water-based painting (see finishing). On request RAL painting.

Maintenance.

O _____ I _____ I _____

paint. Secondly, proceed to the drafting of a good water-based paint for wood with brush or spray, as indicated on the product. The product must ultimately be left to dry (usually a time varying between 2 and 12 hours, depending on the amount and mode of application and climatic conditions). For products that have undergone treatment in oil and that need a touch up, simply proceed to lightly sand the surface to remove deposits of dirt, and then apply a new layer of oil. It

(there is no standard but the timing depends on the conditions of "stress" in the environment where the product is placed).
In case of any doubt about the proper maintenance procedure, please contact the Metalco Quality Department for advice.

FINISHING

A. Pigmented vegetable oil impregnation treatment:

Attention: wood surfaces treated with oil naturally tend to turn grey in a variable period of time depending on the environmental characteristics of the place of installation of the product.

The formation of the grey patina is a physiological reaction and is a self-protection of wood against weathering, while not affecting the quality of the product. It is still possible to reduce the greying of the wood by making a regular renewal of the oiling process (see "Maintenance").

CYCLE FOR OILING

- 1 Automatic brushing
- 2 Manual application of water-based oil with a spray gun and brush
- 3 Storage for air drying



It is still possible to reduce the greying of the wood by making a regular renewal of the oiling process (see "Maintenance").

B. Water- based paint

Attention: Metalco strongly recommends not to choose varnished wood when a regular maintenance is not possible (see "Maintenance") and/or in case of severe atmospheric conditions (saline area, high pollution, steady sun and high temperature exposure, etc.).

In such conditions, in fact, varnish coat will quickly deteriorate, causing a visible peeling.

PAINTING CYCLE

- 1 Base coat with catalyzed insulation (160 microns) - spray application*
- 2 Drying (4-6 hours) and automatic brushing*
- 3 Coat with water-based paint (200 micron) spray application
- 4 Storage for air drying

(* Only on Okume)



WOOD PLASTICS COMPOSITE

On some products, as an alternative to wood, Metalco proposes also WPC ("Wood Plastics Composite"). It is a material made from vegetable elements, or product and/or manufacturing process.

Maintenance. For greater durability of all parts in WPC, regular cleaning with water and suitable detergents is necessary. In case of any doubt about the proper maintenance procedure, please contact the Metalco Quality Department for advice.

N.B.: The images reproduced in these pages are merely indicative; please refer to physical samples.

AWARDS, ACKNOWLEDGMENTS & ACHIEVEMENTS



"ADI DESIGN INDEX" AND "COMPASSO D'ORO"

Products included in the ADI DESIGN INDEX:

2004: APOLLO bollard/bike stand (Design: Staubach & Kuckertz)

2005: GHOST litterbin (Design: Raffaele Lazzari)

2006: CHEOPE outdoor kitchen (Design: Alfredo Tasca)

2007: SEDIS bench (Design: Antonio Citterio with Toan Nguyen)

2009: PALUS bollard (Design: Antonio Citterio with Toan Nguyen)

2013: OSMOSE public transit station (Design: AUREL DESIGN URBAIN)



Products included in the HISTORICAL COLLECTION OF THE COMPASSO D'ORO AWARD, for receiving a MENTION:

2008: XXI Edition of Premio Compasso D'Oro:
GHOST litterbin (Design: Raffaele Lazzari) and SEDIS bench (Design: Antonio Citterio with Toan Nguyen)

2011: XXII Edition of Premio Compasso D'Oro: **PALUS bollard (Design: Antonio Citterio with Toan Nguyen)**



ADI Compasso d'Oro Award

pre-selection made by ADI Permanent Observatory of Design, consisting of a commission of experts, designers, critics, historians, specialized journalists. This pre-selection brings to the formation of ADI Design Index, collecting, year after year, the best of Italian design put into production. Every three years, a special Jury selects some products among the ADI Design Index, dividing them in "premiati" (Awarded) and "segnalati" (Mentioned). Awarded products as well as Honourable Mentioned products enters the permanent Historical Collection of the Compasso d'Oro Award, included since 2004 in Italy's national heritage with a Ministerial Decree, for being "of exceptional artistic and historical interest".



Product: LUCKY WOOD bench (Design: Alfredo Tasca)

«LE GRAND PRIX DU DESIGN URBAIN DE LA VILLE DE METZ 2003»

Awarded at the 6th edition of the Salon Professionnel URBEST



Product: GEA bench (Design: Staubach & Kuckertz)

FIRST PRICE "CITTÀ DI ODERZO AZIENDA E DESIGN 2004"



Product: VOLO bench (Design: Alessandro Lenarda)

Included in the "COLLEZIONE FARNESINA DESIGN", travelling exhibition, Rome and Worldwide:

January 2010: Casa Italia, XXII Winter Olympics Games, Vancouver

June 2010: Casa Azzurri FIFA World Cup, Pretoria

November 2010: Culture European Capital, Istanbul

February-April 2011: Holon National Museum, Tel Aviv

May-September 2011: Ara Pacis Museum, Rome

November 2011: Palais des Rais, Algeri

December 2011-January 2012: Centre National d'Art Vivant, Tunisi

February 2012: Ecole Nationale d'Architecture, Rabat

E D
A E II O L
O E D S L

October-November 2012: Italian cultural Institute "Palazzo della Farnesina e le sue collezioni", Rome
Exposed at Design Museum Holon, Tel Aviv (permanent exhibition)
Exposed at Modern and Contemporary Art Gallery, Roma Capitale

October 2012-January 2013: "Welcome to design-the best Made in Italy", Mosco



Product: LIBRE bench (Design: Alfredo Tasca)

exposed at the exhibition "Disegno e Design. Brevetti e creatività italiani", Tongji University, Zhonghe Building, Shanghai

included in the book "Disegno e Design Brevetti e creatività italiani", 2010



Product: LIBRE TORSION (Design: Alfredo Tasca)

A D

Product: OSMOSE public transit station (Design: AUREL DESIGN URBAIN)

Received the "Etoile et le prix du Design de Service de l'Observateur du Design" 2013

Received a "SPECIAL MENTION" at the "GERMAN DESIGN AWARDS 2014"



Product: ULURU modular bench (Design: Andrea Morgante Shiro Studio)

Muuuz International Awards

Winner 2016



METALCO Award: "PREMI FESTIVAL CITTÀ IMPRESA 2010"

Motivation: "Metalco has been awarded for facing the economic crisis with the audacity of innovative research, and for being able to surprisingly grow, despite the general economic situation, thanks to original and new street furniture proposals"





OS24 class. III-bis
OG9 class. III-bis
OS18-a class. III



The mark of
responsible forestry



hEN 1090-1: 2009+A1:2011
UNI EN ISO 3834-3:2006



UNI EN ISO 9001:2008



CONCEPT:
Sabrina Tubia
Metalco Marketing Dept.

FOTO - PHOTO:
Archivio Metalco / Metalco Archive
De Sandre / Photo Projects
HQ Architects
Marina Tasca
MZ Manu Zatti
Studio Rocci
urnato.it
®Y.Monel

LAYOUT ESECUTIVO / EXECUTIVE LAYOUT:
marigraf.it

STAMPA / PRINTING:
AGCM (PN)

© Tutti i diritti riservati.
E' vietata la riproduzione anche parziale di immagini e testi.
© All rights reserved.

The reproduction of images, drawings and texts, even if
partial, is forbidden.

METALCO
Via della Fornace, 44
31023 Castelminio di Resana (TV) ITALY

Finito di stampare nel mese di Aprile 2017
Prima edizione

Printed in April 2017
First edition

La Metalco Srl si riserva di apportare ai propri prodotti
qualsiasi modifica ritenuta utile al miglioramento qualitativo
degli stessi, sia dimensionale che strutturale.
Foto, disegni e testi non hanno carattere contrattuale.

Metalco Srl reserves the right to modify the
dimensions and structure of its products at any time without
prior notice in order to improve quality and durability.

Photos, drawings and texts are not contractual.
Per eventuali modifiche o aggiornamenti fare riferimento al
sito web: www.metalco.it.

For possible modifications or updates, please refer to the
web site: www.metalco.it



METALCO SRL

VIA DELLA FORNACE, 44
31023 CASTELMINIO DI RESANA (TV)
ITALY

T. +39 0423.7863
F. +39 0423.786400

www.metalco.it
info@metalco.it