

Pumps, Pumping Systems and Ancillaries

NEWTON CP Pumps

A Range of High Quality Clean Water Pumps

Rev 3.2 - 13 December 2022

PRODUCT CODE - P27 to P32

INTRODUCTION

The Newton [CP150](#), [CP250](#), [CP400](#) and [CP750](#) are a range of high quality clean water pumps ideally suited for the removal of ground water from basements and cellars as well as surface water collected in light-wells, patios and terraces. The vertical operation float switch ensures that the pumps operate within their footprint, removing the possibility of the float snagging during operation and allowing the pumps to be used within smaller sumps. The vertical float switch of the CP250, CP400 and CP750 is also very flexible, allowing the pump switching height to be adjusted both in terms of the height between the 'on' and 'off' positions, as well as the height of the switch relative to the pump.

The Newton CP Pumps are suitable for use with [Newton Victron Power Inverters](#) to give continual pumping even during power outage.

Newton CP Pumps are supplied with a 1-year manufacturers warranty or a 3-year back-to-base warranty if the pumps are serviced by a Newton approved service engineer.

The Newton CP150 is an automatic pump only, whilst the CP250, CP400 and CP750 pumps are sold as both manual and automatic versions. Newton CP Pumps can be purchased as pumps only, or within selected packaged pumping systems.

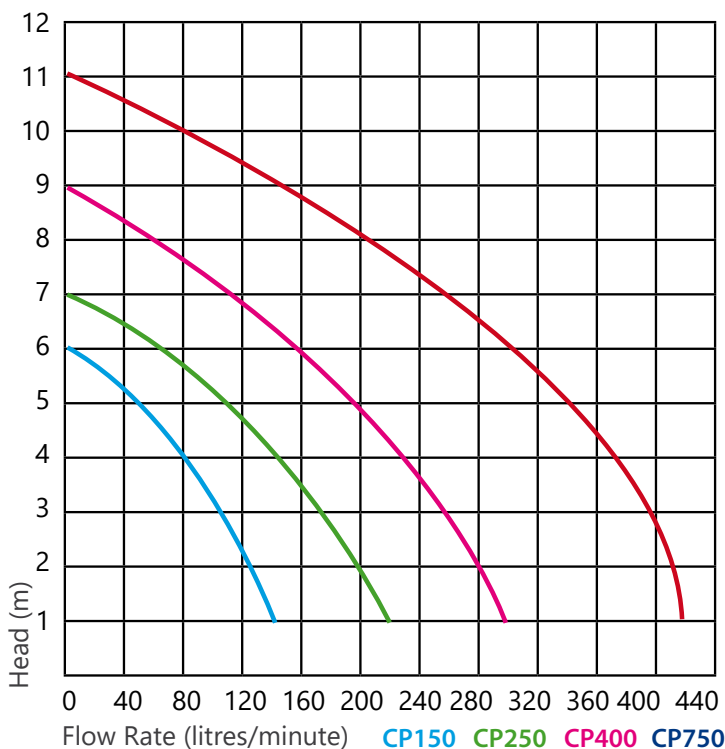

CP250

KEY BENEFITS

- 3-year warranty - see page 2
- Thermal overload protection against motor burnout
- Non-clogging vortex impeller
- Protection against motor burnouts due to a locked impeller
- Double mechanical seals ensure increased durability against particle abrasion and wear
- Anti-airlock impeller housing ensures that the pump is able to remove trapped air even when the sump was previously dry
- High performance and efficiency even with a low current
- Unique vertical float allows complete adjustment of the start and stop heights
- Continued pumping even during power cuts when used with Newton Power Converters - see page 4.

TYPICAL APPLICATIONS

Primarily designed to be used with Newton sump systems for the removal of ground water collected by the [Newton CDM](#) Type C basement waterproofing system, Newton CP Pumps are also suitable for:

- Flooded basements and cellars
- Light-wells
- Surface water
- Reservoirs and water holding vessels

NEWTON PUMPS, PUMPING SYSTEMS AND ANCILLARIES

NEWTON CP Pumps

A Range of High Quality Clean Water Pumps

TECHNICAL DATA

Features	CP150	CP250	CP400	CP750	Units
Purchase Code - Automatic Version	P30	P31	P32	P33	
Purchase Code - Manual Version	N/A	P29	P28	P27	
Pump Design	Vortex				
Outlet	2" BSP	2" BSP	2" BSP	2" BSP	
Max Soft Solids Handling	5	5	10	15	mm
Recommended Discharge Pipe Size	50	50	50 / 63	63	mm
Maximum Pumping Head	6.0	8.0	10.0	11.0	m
Maximum Flow Rate	160	210	290	410	litres/minute
Flow Rate at 4m Head	80	120	220	295	litres/minute
Pump Switching	Automatic by pump float or by separate pump control				
Float Switch	Vertical - Fixed	Fully adjustable vertical operation			
Pump Start Level	210	Fully adjustable			
Lowest or Stop Water Level	80/110	80	80	127	mm
Length	190	190	215	260	mm
Width	140	140	155	160	mm
Height - Handle/Gland	366/374	366/374	385/395	419/434	mm
Dry Weight	5.5	11.0	12.0	15.0	kg
Clean Water Pumping	Yes				
Effluent Pumping	No				
Sewage Pumping	No				
Fluid Temperature Range	0 to 40				°C
Power Supply - Single Phase	230				Volts
Motor Output	150	250	400	750	Watts
Start Current	5.6	7.4	10.5	15.8	Amps
Rated Current	1.8	2.1	2.4	3.4	Amps
Body Material	Stainless Steel (304)				
Shaft Material	Stainless Steel (410)				
Mechanical Seals	Double Carbon Ceramic				



CP150

WARRANTY

Newton CP Pumps are supplied with a 1-year manufacturers warranty from the proven date of installation, or the date of purchase if this cannot be verified. A 3-year warranty is available if the pumps are serviced at intervals agreed by a Newton approved service engineer. In all cases, the warranty is 'back-to-base'. Newton Waterproofing Systems have a returns policy and any issues regarding pumps under warranty should in the first instance be referred to our Head Office by contacting 01732 360 095. Please see our Terms & Conditions of Sale for further information.

STORAGE

Store in dry conditions at temperatures between 5°C and 35°C. Do not expose to freezing conditions.

NEWTON CP Pumps

A Range of High Quality Clean Water Pumps

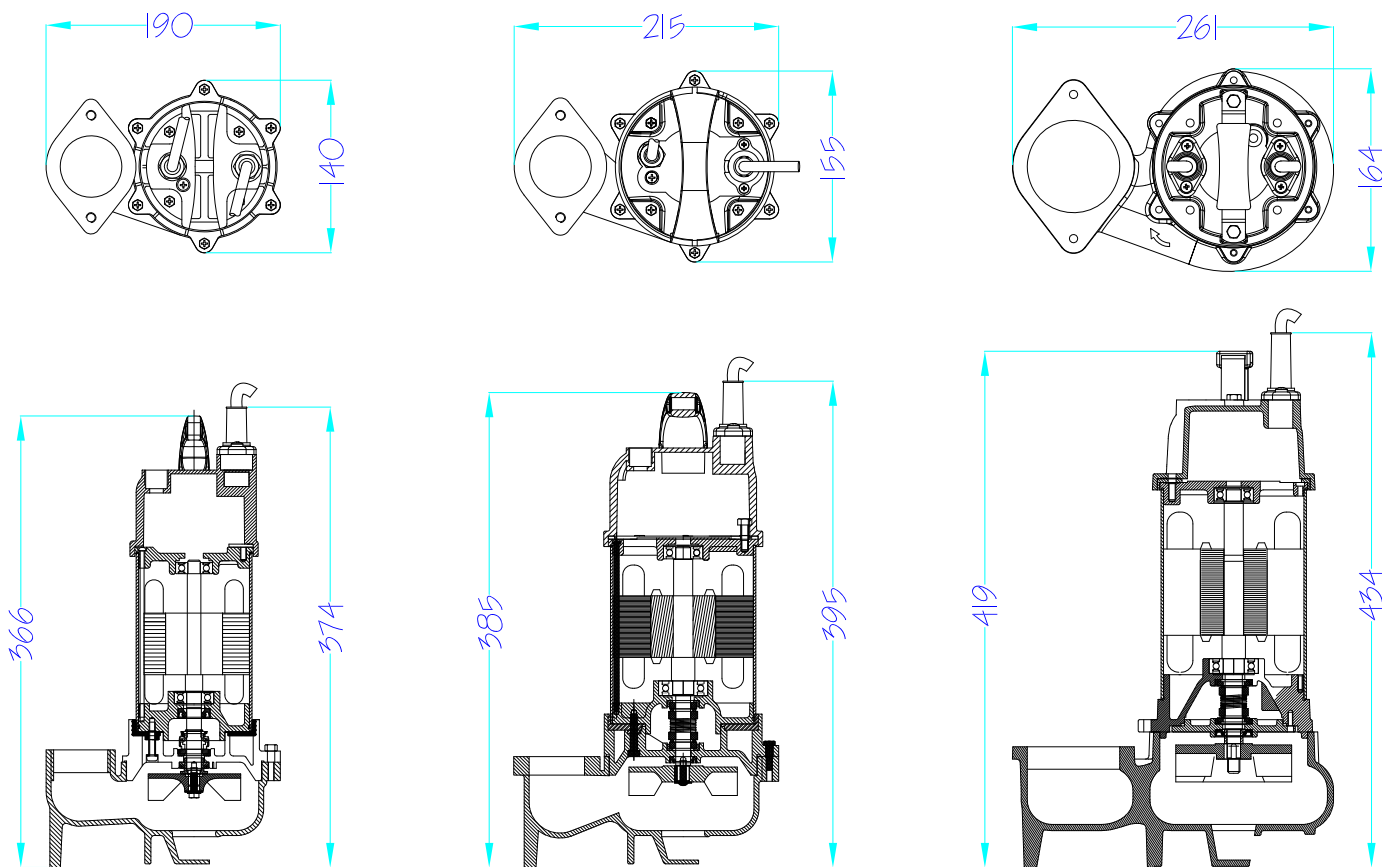

CP150 & CP250

CP400

CP750

SUPPLIED PIPE AND PIPE FITTINGS

Newton CP Pumps are supplied with pipe fittings ready to receive pressure rated pipe, the recommended pipe for pumps. The table on page 2 confirms pipe suitability. Options for pipe connections are available and confirmed on page 4. Please specify which pipe connection is required with the pump(s) when purchasing.

The pumps are also supplied with one-way-valves (check valves). The one-way-valves for the CP250 and CP400 are designed to screw directly into the pump body.

The CP750 is not supplied with a one-way-valve and so the valve, if required, must be ordered when the pump is purchased. Please see pipe and valve options across the page.

Pump Name	CP150,CP250 & CP400	CP750
50 mm rising main	Suitable	Suitable
63 mm rising main	Not Suitable	Suitable
Supplied valve	None	None
Outlet size	CP150 & CP250: 1 1/2" threaded socket CP400: 2" threaded socket	2" threaded socket

PIPE & VALVE OPTIONS

CP150, CP250

Supplied with 1 1/2" BSP threaded socket
Adaption to female socket ready for 50 mm pressure rated pipe - Newton purchase code PP57

CP400

Supplied with 2" BSP threaded socket
Adaption to female socket ready for 50 mm pressure rated pipe - Newton purchase code PP33

CP750

Supplied with 2" BSP threaded socket
Adaption to female socket ready for 50 mm pressure rated pipe - Newton purchase code PP33

50 mm Cone Valve for use with 50 mm pressure rated pipe - Newton purchase code V2

Adaption to female socket ready for 63 mm pressure rated pipe - Newton purchase code PP44

63 mm Cone Valve for use with 63 mm pressure rated pipe - Newton purchase code V8

NEWTON CP Pumps

A Range of High Quality Clean Water Pumps

PUMPING SYSTEMS

Newton CP Pumps are fitted to the following pumping systems:

[Newton Titan](#)

[Newton Titan-Pro](#)

[Newton Trojan-Pro](#)

ELECTRICAL SUPPLY

The Newton CP Pumping range require single phase 230V AC power supply. It is advisable that all pumps are connected to their own individual power supply directly from the consumer board so that each of the pumps does not share a consumer board supply with the other pump or with any other electrical circuit or device. In reality, this is normally only achievable with new-build properties or where fundamental refurbishment of the whole property or the electrical supply is to be undertaken.

Where it is not planned or possible to have each pump connected to a separate supply from the consumer board, it is preferable that each pump is supplied from a separate circuit. If this is not possible, each pump should be connected to a separate fused and switched spur or socket.

Each separate circuit should have its own RCD protection as required by the 17th Edition Wiring Regulations. The RCD should be correctly sized at 30mA so as not to trip during normal pump start or pump run parameters.

It is preferable for the pumps to be wired to the rear of a spur. The spur should be switched and have a neon light confirming the 'on' position. Pumps may be plugged into wall sockets - again these should be switched and have neon light notification of the 'on' position. It is recommended that the spur or socket have a label confirming that the switch must not be switched off unless in an emergency.

The spur or socket should be fitted with the correctly sized fuse appropriate to the motor size of the connected pump:

CP150 & CP250 - 5 amps

CP400 - 10 amps

CP750 - 13 amps

The spur or socket should be located in direct eye line of the sump and to the wall closest to the sump so that in an emergency it is obvious which switch will turn off the pump/s.

LIMITATIONS

Not suitable for:

1. Effluent or washing machine waste
2. Sewage
3. Continuous pumping above 40°C. Pumps can be used to excavate hot water from boiler leaks etc Only for a maximum of 10 minutes pumping in one hour (use hot water capable pumps - please contact Newton Waterproofing Systems for further information)
4. Water with pH value above 10 or below 4 (use pumps suitable for corrosive water - please contact Newton Waterproofing Systems for further information)
5. Sea water (use sea water pumps - please contact Newton Waterproofing Systems for further information)

INSTALLATION INSTRUCTIONS

Please see pump installation sheet supplied within pump packaging (also available from our website).

PACKAGING & HANDLING

Pumps are supplied in reinforced and protective cardboard boxes. Please handle with care.

SERVICING

Newton pumps should be serviced by trained and qualified pump engineers only. It is recommended that pumps are serviced within 6 months of installation and then at service engineers discretion, but with at least one inspection or service every 12 months. Please call Newton Waterproofing for an approved service engineer in your area.

SPECIFICATION

Newton Waterproofing Systems work in partnership with RIBA NBS who publish our products on [NBS Source](#). The platform integrates seamlessly into project workflows, providing all product data from Newton's NBS BIM Objects, NBS Plus Clauses and RIBA Product Selector into one single source of product information.

NBS Source also hosts a large selection of Newton [case studies](#), as well as product [literature and certifications](#).

A wide range of drawings are available [on our website](#).

HEALTH & SAFETY

Product should only be used as directed. Pumps contain lubricating oil. We always recommend that the Material Safety Data Sheet (MSDS) is carefully read prior to use of the pump. Our recommendations for protective equipment should be strictly adhered to for your personal protection. The MSDS is available upon request from Newton Waterproofing Systems or online via our website. Please see contact details below.

NEWTON CP Pumps

A Range of High Quality Clean Water Pumps

BATTERY BACK-UP OPTIONS

Pumping System	Inverter	Battery	Battery Back-up Purchase Code
CP150 & CP250	12/500/20	40 Ah	BBS1
CP150 & CP250	12/500/20	60 Ah	BBS2
CP400	12/800/35	60 Ah	BBS3
CP400	12/800/35	100 Ah	BBS4
CP750	12/800/35	100 Ah	BBS4
CP750	12/1600/70	100 Ah	BBS6
CP750	12/1600/70	200 Ah	BBS7

uPVC PRESSURE RATED PIPE AND FITTINGS

50 mm Pipe - 2.5 m lengths - Newton Code PP1
50 mm 90 degree elbows - Newton Code PP2
50 mm 45 degree elbows - Newton Code PP3
50 mm female-female sockets - Newton Code PP4
50 mm Tee - Newton Code PP5
50 mm wall mount clips - Newton Code PP6
1½" BSP to 50 mm Hosetail - Newton Code PP28
1½" BSP to 50 mm Socket - Newton Code PP43
63 mm Pipe - 2.5 m lengths - Newton Code PP10
63 mm 90 degree elbows - Newton Code PP11
63 mm 45 degree elbows - Newton Code PP12
63 mm female-female sockets - Newton Code PP13
63 mm Tee - Newton Code PP14
63 mm wall mount clips - Newton Code PP15
uPVC Solvent - 0.5 litre - Newton Code G1
uPVC Solvent - Wet 'R Dry - 240 ml - Newton Code G2
uPVC Pipe Primer - 473 ml - Newton Code G3

uPVC PRESSURE RATED PIPE AND FITTINGS

Newton Waterproofing Systems reserve the right to update product literature at any time. Please always refer to our [website](#) for the latest versions.