

Uniclass L21725	August 2013
CI/SfB (52.9)	

ACO Building Drainage

Grease management



Product catalogue

ACO Gravity Grease Separators





ACO Building Drainage

Our built environment is becoming ever more complex. Applications are becoming more sophisticated and the increasing pressure of regulations and standards makes achieving design, performance and financial goals ever tougher.

Our mission: to eliminate design risk, to reduce installed and life cost and to deliver exceptional finish and performance in every product application.

Our global resources and fabrication capacity make it possible for us to deliver best value, both with our standard products and with our bespoke designs. Confidence is further assured with quality systems that are in accordance with ISO 9001-2008.

ACO Building Drainage is a division of ACO Technologies plc and part of the worldwide ACO Group. The Group has sales in excess of £600 million worldwide with production facilities in the UK, Germany, France, Switzerland, Denmark, Spain, Poland, Czech Republic, Australia and the USA. In total more than 3900 people are employed in over 40 countries throughout the world.

ACO Building Drainage

Enquiries Team:

Tel: +44(0)1462 816666
Fax: +44(0)1462 851490
Email: abdestimating@aco.co.uk

- A complete pricing service to stockists, contractors and clients.

ACO Building Drainage

Customer Services Team:

Tel: +44(0)1462 816666
Fax: +44(0)1462 851490
Email: abdcommercial@aco.co.uk

- Product availability, delivery lead times, and all other queries including collections, returns and complaints.

ACO Building Drainage

Design Services Team:

Tel: +44(0)1462 816666
Fax: +44(0)1462 851490
Email: abdtechnical@aco.co.uk

- Technical and installation advice.
- Detailed design and 'Value Engineering' advice.
- Hydraulic calculations and AutoCAD drawings.
- Advice on the suitability of ACO equivalent products.

ACO Building Drainage

Marketing and Media Support

Tel: +44(0)1462 816666
Fax: +44(0)1462 851490
Email: abdmarketing@aco.co.uk

- For all product brochures, imagery or merchandising material requests.



collect:

- Stainless Steel and Galvanised Steel Channels
- Stainless Steel Gullies
- Pipe System
- Roof / Balcony Drainage
- Wetroom & Shower Drainage



clean:

- Grease Management Systems



hold:

- Anti-flood Backflow Protection Systems



release:

- Lifting Stations*

*Available in 2014

Office address and contact details:

ACO Building Drainage
ACO Business Centre
Caxton Road
Bedford
Bedfordshire
MK41 0LF

Tel: +44(0)1462 816666
Fax: +44(0)1462 851490
Email: abdinfo@aco.co.uk

Company Registration No: 1854115
VAT No: GB 650 7977 05

www.acobd.co.uk

For quick access to our website, scan:



Contents

The Need for Fat, Oil and Grease Management	
Local effects of fats, oils and grease (FOGs)	4
Regional effects	4
Legislation and Regulation	4
ACO Gravity Grease Separators	
When to use a Grease Management System	5
Choosing a Grease Management System	6
Separator Process Overview	7
Selecting a Gravity Grease Separator	8
ACO Below Ground Grease Separators	
ACO Lipumax P - Features and Benefits	11
ACO Lipumax P - Product Range Overview	12
ACO Lipumax P-B - Technical Data	13
ACO Lipumax P-D Intermediate - Extension Stage 1 - Technical Data	15
ACO Lipumax P-DM - High Extension Stage 2 - Technical Data	17
ACO Lipumax P-DA Premium - Extension Stage 2 - Technical Data	19
ACO Lipumax P Product Range – Accessories	21
ACO ECO-FPI Product Range Overview - Features and Benefits	24
ACO ECO-FPI - Technical Data	25
ACO ECO-FPI Product Range – Accessories	26
ACO Free Standing Grease Separators	
ACO ECO-JET and HYDROJET Product Range Overview	27
ACO ECO-JET-GD Split Design Series - Technical Data	28
ACO ECO-JET-O and HYDROJET-O Series	29
ACO ECO-JET O (Basic Model) - Technical Data	30
ACO ECO-JET OD Extension Stage 1 - Technical Data	31
ACO ECO-JET OS Extension Stage 2 - Technical Data	32
ACO HYDROJET OSE Extension Stage 2 - Technical Data	33
ACO HYDROJET OA Extension Stage 3 - Technical Data	34
ACO HYDROJET OAE Extension Stage 3 - Technical Data	35
ACO ROUND ECO-JET-R and HYDROJET-R Series	36
ACO ECO-JET R (Basic Model) - Technical Data	37
ACO ECO-JET RD Extension Stage 1 - Technical Data	38
ACO ECO-JET RS Extension Stage 2 - Technical Data	39
ACO HYDROJET RSE Extension Stage 2 - Technical Data	40
ACO HYDROJET RA Extension Stage 3 - Technical Data	41
ACO HYDROJET RAE Extension Stage 3 - Technical Data	42
ACO ECO-JET and HYDROJET – Accessories	43
Bespoke Pumping Station Solutions	
Application example	44
ACO Pipe® Stainless Steel Pipe Systems	
Typical applications	45
Product benefits	45
ACO Below Ground Separators – Installation Recommendations	
ACO Lipumax P	46
ACO ECO-FPI	47
ACO Free-Standing Separators – Installation Recommendations	
ACO ECO-JET and ACO HYDROJET	48
Operation, Maintenance and Accessories	
General Information	50
Start Up and System Characterisation	50
Disposal	50
Operating log	50
Maintenance	50
Model Specification Clause	
NBS Plus	51
EU Conformity	
Declarations of Performance	51



The Need for Fat, Oil and Grease Management

Local effects of fats, oils and grease (FOGs)

One of the greatest drainage problems faced in kitchens and food processing areas is the accumulation of fats, oils and grease within the drainage system.

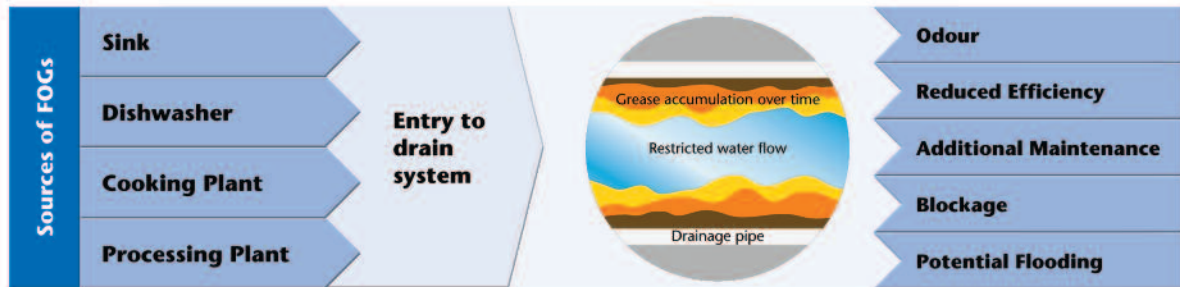

Note: As FOGs cool in the drainage system they can solidify. If untreated, accumulation eventually leads to drainage system failure with potential health hazards within the food preparation area.

Regional effects

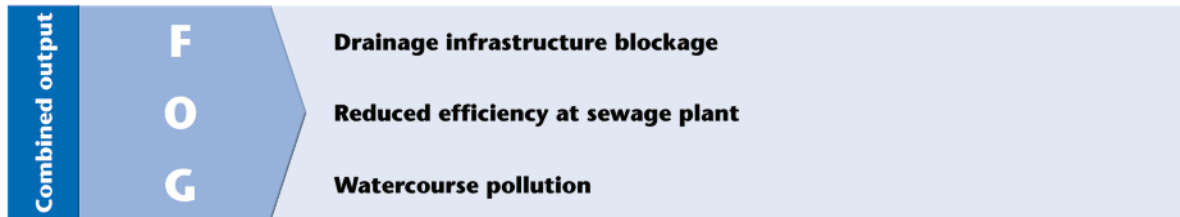

Legislation and Regulation

The problem of FOG pollution is being addressed at a regional and national level. Recent incorporation into Building Regulations and the proactive stance from many Local Authorities require that the problem is, in part, managed at source.

Driver	Comment
Water Resources Act 1991	Offence to pollute watercourse
Water Industry Act 1991	Offence to impair operation of sewer
Building Regulation Part H1 (S2.21)	Effective means of grease removal from commercial hot food premises required
Local Authority	May stipulate specific performance requirements for FOG management

When to use a Grease Management System

FOGs and specified output quality

Vegetable and animal fats are separated through the differential density mechanism in the separator, however, some residual fats always remain in the output effluent.

Regulatory authorities may require specific output quality and may test the installation for performance.

Increasing levels of sophistication are available and can be discussed with us on a bespoke basis.

Stable emulsions

Certain FOGs may form a stable emulsion, e.g. those created during dairy production processes and are not suitable for treatment in Gravity Grease Separators.

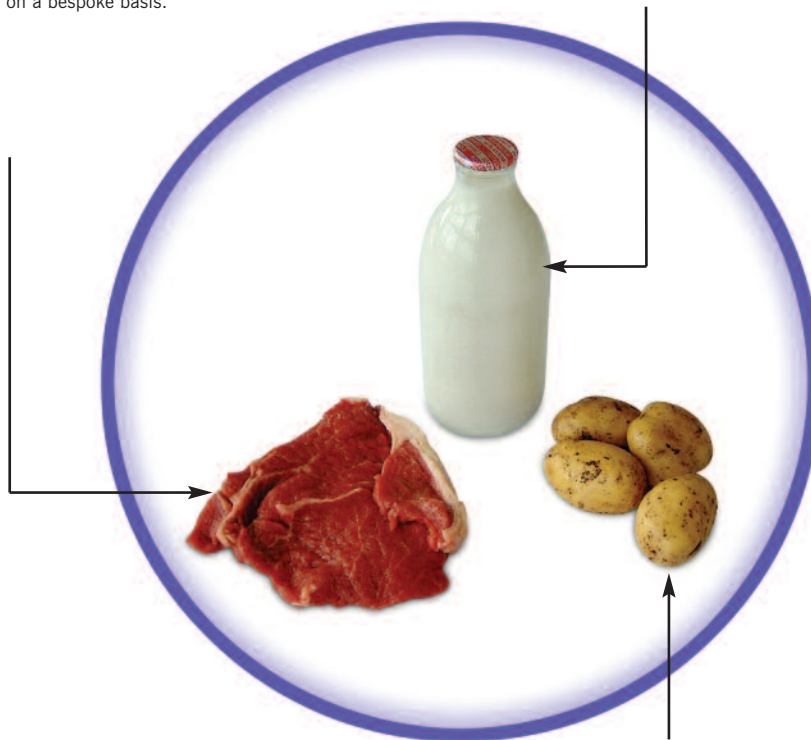

Starch

Certain foods such as potatoes and rice produce high levels of starch. Excessive amounts of starch form an adhesive like gel, especially in turbulent water, potentially blocking or reducing flow in associated pipework.

Gravity Grease Separators are not suitable for these applications but ACO Building Drainage does offer a range of starch separators. Please contact us for further details.

Choosing a Grease Management System

Compared with some European countries, the UK has only recently addressed the problems arising from fats, oils and grease through national mechanisms such as the Building Regulations which now enforce control in specific businesses within Europe. Differences also exist in the extent of assessment and policing of output quality.

The lack of consistent, regulated control means that demand, and therefore supply of appropriate product has been limited, with subsequent variability in the performance of the various products on offer.

ACO Building Drainage offer a choice of grease management systems: a range of biological or enzyme based traps, or separators based on differential density, often referred to as gravity separators. There are a number of factors to be taken into account when deciding on a suitable system.

Factors to Consider	Biological Grease Traps*	Gravity Grease Separators
Mode of operation - principal effect	<ul style="list-style-type: none"> Enzymes and bacteria breakdown long chain FOG molecules preventing drain blockage 	<ul style="list-style-type: none"> Differential density causes FOGs to float and solids to sink. FOGs and solids retained in separator
Maintenance regime	<ul style="list-style-type: none"> Linked to automated enzyme injection system Requires routine periodic enzyme replenishment Requires periodic sludge removal Allows large particle removal via sediment basket Certain variables adjustable on site e.g. dosing frequency 	<ul style="list-style-type: none"> Requires periodic FOG removal by licensed waste disposal contractor No user adjustable maintenance variables other than contractor visit frequency Consideration of accessibility for maintenance Manual, semi-automated or fully automated integrated servicing facilities
Physical size and location	<ul style="list-style-type: none"> For equivalent 'meals per day' performance, biological traps are far smaller Allows installation in smaller premises or where space restrictions apply Space saving 'under sink' units available Internal or external installation possible 	<ul style="list-style-type: none"> Physically large and unlikely to be sited in kitchen area Access to free-standing systems located within the building Internal or external installation possible
Design guidance	<ul style="list-style-type: none"> No British or European Standard exists for biological traps Manufacturers offer own sizing methodologies 	<ul style="list-style-type: none"> Separator geometries clearly defined in BS EN 1825
Size selection	<ul style="list-style-type: none"> Based on assessment of 'meals per day' production in kitchen or plant (especially suitable where other data is not available) 	<ul style="list-style-type: none"> BS EN 1825 offers both 'meals per day' as well as alternative sizing methods, such as specific plant output flow rates. BS EN 1825 also considers: <ul style="list-style-type: none"> Influent temperature FOG density variations Use of cleaning or rinsing agents This allows precise sizing where such variables are known, for example in food processing applications
Managing sludge, silt and other relatively dense particles	<ul style="list-style-type: none"> Allowance made within unit design and is a fixed volume Larger particles or debris can be removed by silt basket 	<ul style="list-style-type: none"> Design criteria calls for a minimum sludge volume (litres) of 100 x nominal size (NS), with option for 200 x NS for meat processing plant and abattoirs

*Please refer to ACO Biological Grease Traps product catalogue for more information and product options.

Separator Process Overview

All ACO separators are designed to BS EN 1825 Part 1 Grease Separators Principles of Design, Performance and Testing, Marking and Quality Control.

Maintenance options available

(according to separator type).

- Pumped outlet connection using Bauer couplings
- Advanced high pressure (175 bar) cleaning system manual or automatic control
- Integrated disposal pump to assist vacuum disposal tanker

Waste water from kitchens and food processing plants contains a mixture of water, FOGs and food residue solids.

FOGs have a density less than water. Under the correct conditions, these contaminants will naturally float on the water surface.

FOG storage capacity minimum 40 litres x NS (Nominal Size of separator), FOG surface area = $0.25\text{m}^2 \times \text{NS}$.

Periodic maintenance is required to remove the entire contents of the separator for treatment at a sewage treatment plant and is normally carried out by a specialist waste contractor.

Solids have a higher density than water and will fall to the bottom of the separator.

Sludge capacity 100 litres x NS (nominal size of separator) or 200 litres x NS for meat processing plants

Separation compartment capacity dependent on NS size.

Separated FOGs and solids are retained in the separator body whilst "grey" waste water passes through the separator via a submerged outlet.

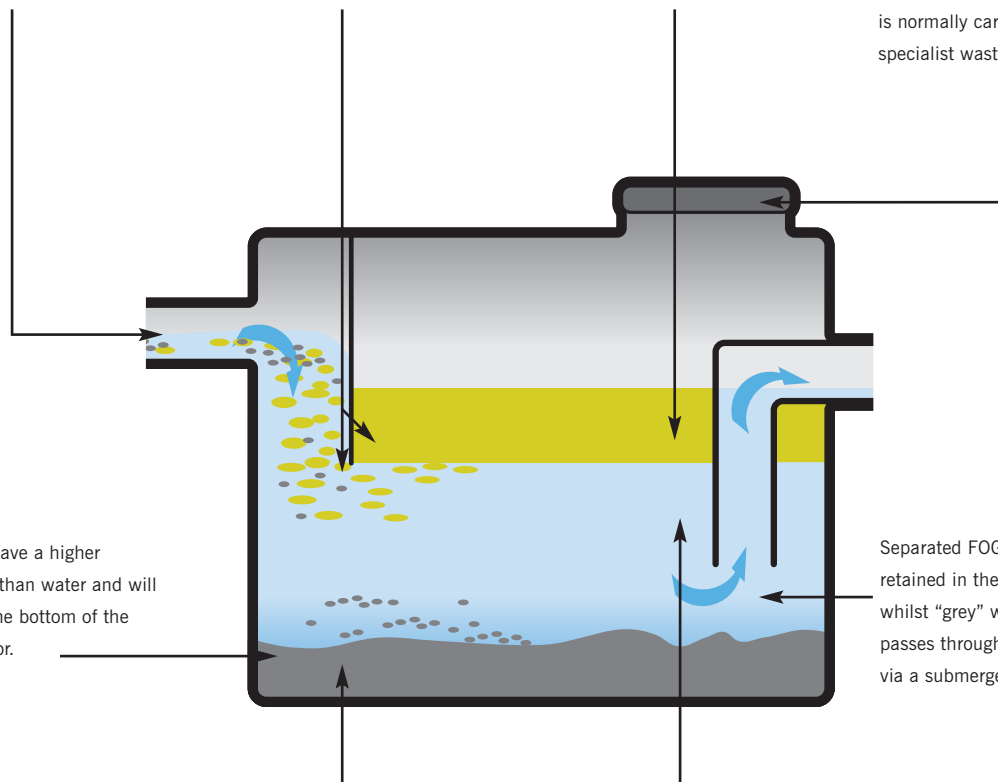

Selecting a Gravity Grease Separator

Stage 1

Consider waste water contents

Although all separators accommodate silt, it is often necessary to remove coarse particles which might otherwise cause problems, for example fish waste, which will putrefy if allowed to enter the separator. Such waste can be removed by use of pre-strainer (e.g. see page 43).

Note: Gravity Grease Separators are not designed to accommodate output from macerators.



Stage 2

Establish separator size

BS EN 1825 describes 3 methods of calculating the nominal size (NS) of a grease separator:

- Per kitchen equipment and type
- Per quantity of meals
- Per meat processing unit

Sizing methods contained in this product catalogue cover the more common applications only. For other sizing methods, refer to BS EN 1825 Part 2 or contact the ACO Building Drainage Design Services Team on 01462 816666 or email abdtechnical@aco.co.uk

Note: An on-line grease separator sizing tool is available on: <http://www.acobuildingdrainage.co.uk/products/gravity-grease-separators.aspx>

Step 1 - Select FOG density

Common FOG densities are:

Fat/Oil	Density (g/cm ³)	Fat/Oil	Density (g/cm ³)	Fat/Oil	Density (g/cm ³)
Animal fat	0.85-0.94	Sesame oil	0.92	Corn oil	0.92
Butter fat	0.91	Sunflower oil	0.92-0.93	Fish oil	0.89-0.94
Coconut oil	0.92-0.93	Vegetable oil	0.95-0.97	Olive oil	0.91

Step 2 - Select kitchen type

The table below details various types of kitchen, as listed in BS EN 1825.

Kitchen Type	Description	Typical kitchen characteristics
A	Hotel <ul style="list-style-type: none"> • High variety of meals available • á la carte menu 	<ul style="list-style-type: none"> • Market fresh produce
B	Restaurant <ul style="list-style-type: none"> • Average variety of meals available • Individual preparation of food with prepared cooking processes 	<ul style="list-style-type: none"> • Market fresh, partly prepared produce
C	Hospital, clinics, care homes <ul style="list-style-type: none"> • Few main menus (2-4) • Prepared in large food containers • Many forms of special foods in small food containers 	<ul style="list-style-type: none"> • Prepared, partly market fresh produce

Step 2 - Select kitchen type (continued)

Kitchen Type	Description	Typical kitchen characteristics
D	Large catering establishment (24h operation)	<ul style="list-style-type: none"> Market fresh produce, large proportion of canned food Few menus per day (1-2) Prepared in few, large food containers
E	Factory and office, canteens, student refectory	<ul style="list-style-type: none"> Kitchen ready, if applicable portioned out and pre-cooked/deep frozen food Few menus Prepared in large kitchens and/or microwave ovens Large proportion of disposable crockery

Step 3 - Calculate nominal size of Gravity Grease Separator

3.1	Select kitchen type (See table in Step 2)	Kitchen Type					Worked Example (Kitchen Type B selected)
		A	B	C	D	E	
3.2	Calculate meals per day where 1 meal = 1 restaurant cover						= 260
3.3	Multiply by: Water volume per meal in litres as stated in BS EN 1825	x 100	x 50	x 20	x 10	x 5	x50 = 13,000
3.4	Multiply by: Peak flow coefficient as stated in BS EN 1825	x 5	x 8.5	x 13	x 22	x 20	x8.5 = 110,500
3.5	Multiply by: Temperature at inlet °C	<ul style="list-style-type: none"> x1.0 if temperature <60°C (most cases) • 1.3 ONLY if temperature is >60°C 					x1.0 = 110,500
3.6	Multiply by: Factor for detergents, dishwasher powders and rinsing agents	<ul style="list-style-type: none"> • If never used, go to stage 3.7 • x1.3 if occasionally used (most cases) • x1.5 if special circumstances (e.g. hospital) 					x1.3 = 143,650
3.7	Multiply by: Factor for fat/oil density in g/cm ³	<ul style="list-style-type: none"> • x1.0 if density ≤0.94g/cm³ (most cases) • x1.5 only if density >0.94g/cm³, otherwise go to stage 8 					Olive oil is mainly used therefore x1.0 = 143,650
3.8	Establish average daily kitchen operation in seconds (3600 seconds per hour)						11 hours x 3600 = 39,600
3.9	Take answer from stage 3.7 and divide answer by answer from stage 3.8						<u>143,650</u> 39,600 = 3.63
3.10	Round up to available NS size Sizes available up to NS 10						3.63 round up to NS 4



Stage 3 - Select separator location



Fats, oils and grease generation



Below ground installation	Above ground installation
Lipumax	ECO-Jet
ECO-FPI	Hydrojet



ACO Lipumax Gravity Grease Separator for below ground installation
Product information on pages 11 - 23



ACO ECO-Jet Gravity Grease Separator for above ground installation
Product information on pages 27 - 43



ACO ECO-FPI Gravity Grease Separator for below ground installation
Product information on pages 24 - 26

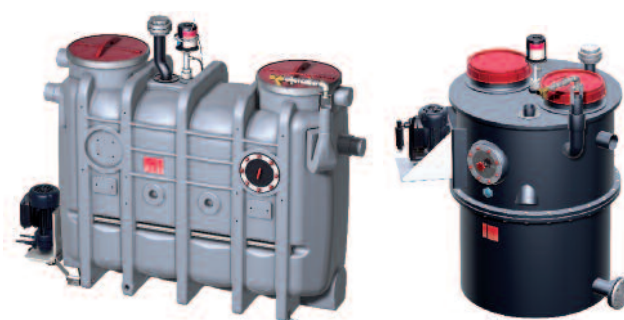

ACO Hydrojet Gravity Grease Separator for above ground installation
Product information on pages 27 - 43

ACO Lipumax P - Features and Benefits

The ACO Lipumax range of below ground gravity grease separators are specifically designed to provide not only efficient separation performance of fats, oils and grease but also to ensure a durable and reliable service life of over 50 years.

Using advanced design, materials and manufacturing techniques, roto-moulding technology provides the below ground tanks the structural integrity to withstand the rigours of site handling and installation as well as the hydrostatic forces generated from changing ground water levels.

All ACO grease separators are manufactured, tested and certified in accordance with BS EN 1825. In addition all separators are individually hydraulically tested to ensure reliability in service.

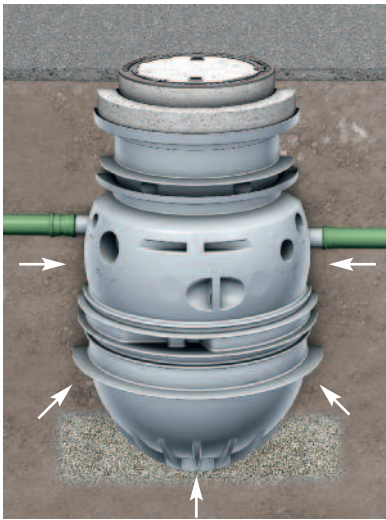

Structural stability

- Rigid one-piece roto-moulded tank construction
- Independently certified calculations enable guarantee on product stability for 50 years

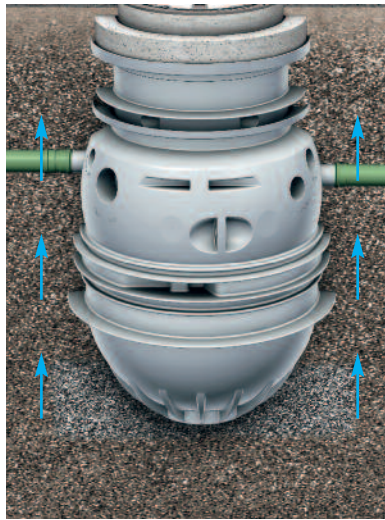

Resistant to buoyancy

- Built-in rib structure provides positive features to key into surrounding concrete
- Resists groundwater to surface levels



Load bearing capacity

- Full load class A15 to D400 capability to BS EN 124
- Optional concrete load distribution plate for D400 applications
- Reduces slab reinforcement requirements

ACO Lipumax P - Product Range Overview



Lipumax P-B Basic

- Most cost-effective solution
- Contents disposal and cleaning via access cover
- Best suited in locations where odours will not be a nuisance during routine maintenance
- Adjustable inlet invert position
- Choice of A15, B125 and D400 access covers to BS EN 124



Lipumax P-D Intermediate

Extension Stage 1

- Odourless disposal to vacuum tanker via remote connection to integrated direct suction line
- Best suited in locations where odours could be a nuisance during routine contents disposal
- Adjustable inlet invert position
- Choice of A15, B125 and D400 access covers to BS EN 124



Lipumax P-DM High – manual control

Extension Stage 2

- Odourless disposal to vacuum tanker via remote connection to integrated direct suction line
- High pressure (175 bar) orbital head internal cleaning facility and no need for cover removal during servicing
- Best suited in locations where odours would be a nuisance during routine cleaning cycles
- Manual control of cleaning/re-fill cycle
- Adjustable inlet invert position
- Choice of A15, B125 and D400 access covers to BS EN 124



Lipumax P-DA Premium – automatic control

Extension Stage 3

- Odourless disposal to vacuum tanker via remote connection to integrated direct suction line
- High pressure (175 bar) orbital head internal cleaning facility and no need for cover removal during servicing
- Best suited in locations where odours would be a nuisance during servicing and minimum time on site to empty and clean separator is required
- Automatic operation of cleaning process
- Adjustable inlet invert position
- Choice of A15, B125 and D400 access covers to BS EN 124



NBS Specification Clause Reference

For relevant NBS specification, refer to NBS section R12 Below Ground Drainage, Clause 630 Grease Traps/Converters and insert the appropriate model reference.

ACO Lipumax P-B - Technical Data



Product Details

- Most cost-effective solution
- Designed, tested and certified to BS EN 1825
- Corrosion-resistant MDPE construction – 50 year life guarantee
- Roto-moulded ribbed construction prevents buoyancy in high water table locations
- Contents disposal and cleaning via access cover
- Best suited in locations where odours will not be a nuisance during routine maintenance
- Adjustable inlet invert position
- Choice of Load Class A15, B125 and D400 600mm clear opening access covers to BS EN 124
- All access covers supplied with 3-point locking

Installation example shows ACO Lipumax P-B NS 4 with Load Class B125 access cover

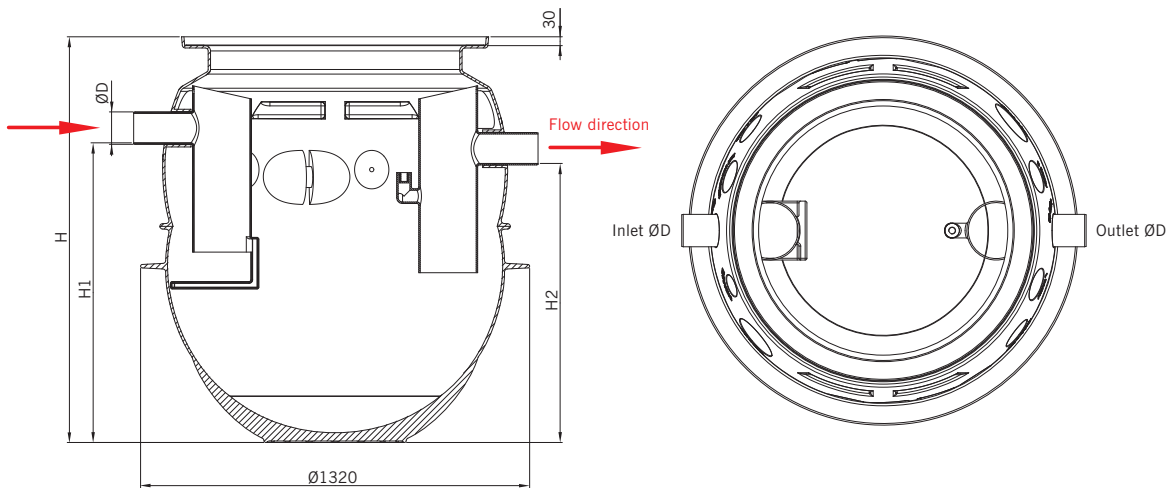

Nominal size	Spigot nominal size	Sludge storage volume (l)	Grease storage volume (l)	Total capacity (l)	ØD (mm)	H (mm)	H1 (mm)	H2 (mm)	Dry Weight (kg)	Product Ref
NS 2	DN 100	245	270	720	110	1377	1015	945	63	3202.80.00
NS 2*	DN 100	460	270	930	110	1594	1235	1165	79	3202.80.10
NS 4	DN 100	460	270	930	110	1594	1235	1165	79	3204.80.00
NS 4*	DN 100	980	270	1465	110	2129	1745	1675	89	3204.80.10
NS 5.5	DN 150	570	230	1465	160	2129	1745	1675	93	3205.80.00
NS 5.5*	DN 150	1065	230	1960	160	2611	2226	2156	108	3205.80.10
NS 7	DN 150	730	285	1675	160	2346	1960	1890	108	3207.80.00
NS 8.5	DN 150	860	360	1900	160	2558	2172	2102	115	3208.80.00
NS 10	DN 150	1005	415	2170	160	2828	2443	2373	125	3210.80.00

*For abattoir and meat processing applications, select double sludge capacity models.

Accessories

- For all accessories please refer to pages 21 - 23



Top Section Load Class A15

- Load Class A15 access cover to BS EN 124
- 600mm clear opening access cover, single EPDM seal
- Concrete frame, cast iron cover
- Variable inlet invert position achieved by on-site trimming of sealed MDPE raising tube (supplied with options 3300.14.01 and 3300.14.02 only)

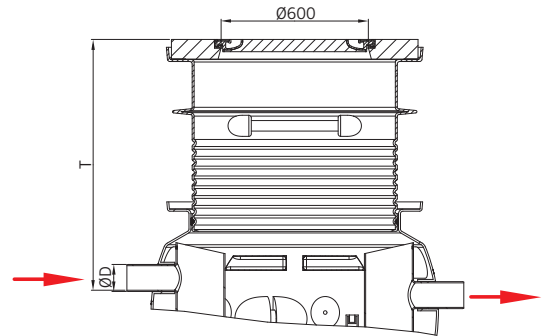

	NS 2 ST 200	NS 2 ST 400	NS 4 ST 400	NS 4 ST 800	NS 5.5 ST 550	NS 5.5 ST 1100	NS 7 ST 700	NS 8.5 ST 850	NS 10 ST 1000	Weight (kg)	Product Ref
T (mm)	420	420	420	420	445	445	445	445	445	145	3300.14.00
	720-1020	720-1020	720-1020	720-1020	745-1045	745-1045	745-1045	745-1045	745-1045	170	3300.14.01
	720-1985	720-1985	720-1985	720-1985	745-1855	745-1855	745-1640	745-1640	745-1640	193	3300.14.02

Top Section Load Class B125

- Load Class B125 access cover to BS EN 124
- 600mm clear opening access cover, single EPDM seal
- Concrete frame, cast iron cover
- Concrete adaptor plate Ø1000mm x 150mm deep
- Variable inlet invert position achieved by on-site trimming of sealed MDPE raising tube (supplied with options 3300.15.01 and 3300.15.02 only)

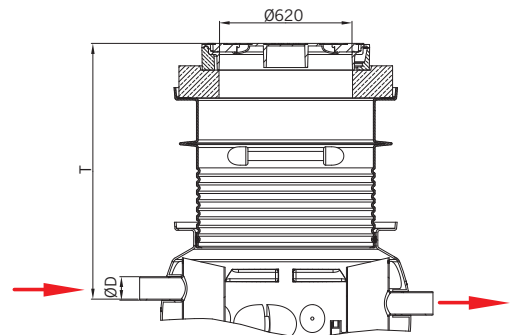

	NS 2 ST 200	NS 2 ST 400	NS 4 ST 400	NS 4 ST 800	NS 5.5 ST 550	NS 5.5 ST 1100	NS 7 ST 700	NS 8.5 ST 850	NS 10 ST 1000	Weight (kg)	Product Ref
T (mm)	585	585	585	585	610	610	610	610	610	282	3300.15.00
	885-1195	885-1195	885-1195	885-1195	910-1220	910-1220	910-1220	910-1220	910-1220	307	3300.15.01
	885-1985	885-1985	885-1985	885-1985	910-1855	910-1855	910-1640	910-1640	910-1640	330	3300.15.02

Top Section Load Class D400

- Load Class D400 access cover to BS EN 124
- 600mm clear opening access cover, single EPDM seal
- Concrete frame, cast iron cover
- Concrete adaptor plate Ø1000mm x 150mm deep
- Variable inlet invert position achieved by on-site training of sealed MDPE raising tube
- Concrete load distribution plate Ø1500mm x 200mm deep to reduce on-site slab reinforcement (supplied with option 3300.16.00 only)

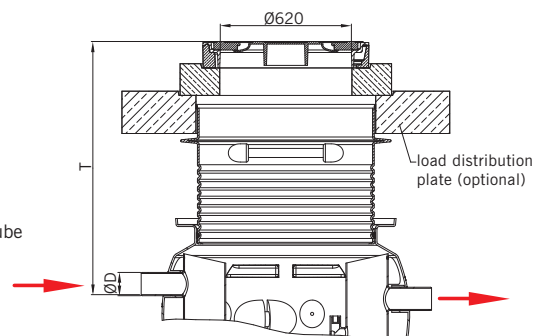

	NS 2 ST 200	NS 2 ST 400	NS 4 ST 400	NS 4 ST 800	NS 5.5 ST 550	NS 5.5 ST 1100	NS 7 ST 700	NS 8.5 ST 850	NS 10 ST 1000	Weight (kg)	Product Ref
T* (mm)	865-1985	865-1985	865-1765	865-1765	890-1855	890-1855	890-1640	890-1640	890-1640	330	3300.17.00
T** (mm)	865-1985	865-1985	865-1765	865-1765	890-1855	890-1855	890-1640	890-1640	890-1640	1030	3300.16.00

*without load distribution plate

**with load distribution plate



ACO Lipumax P-D Intermediate - Extension Stage 1 - Technical Data



Product Details

- Corrosion-resistant MDPE construction – 50 year life guarantee
- Designed, tested and certified to BS EN 1825
- Roto-moulded ribbed construction prevents buoyancy in high water table locations
- Best suited in locations where odours could be a nuisance during routine contents disposal
- Contents disposal to vacuum tanker via remote connection (3" Bauer connector included with product)
- Cleaning via access cover providing minimal odour exposure
- Adjustable inlet invert position
- Choice of Load Class A15, B125 and D400 600mm clear opening access covers to BS EN 124
- All access covers supplied with 3-point locking

Installation example shows ACO Lipumax P-D NS 4 with Load Class B125 access cover

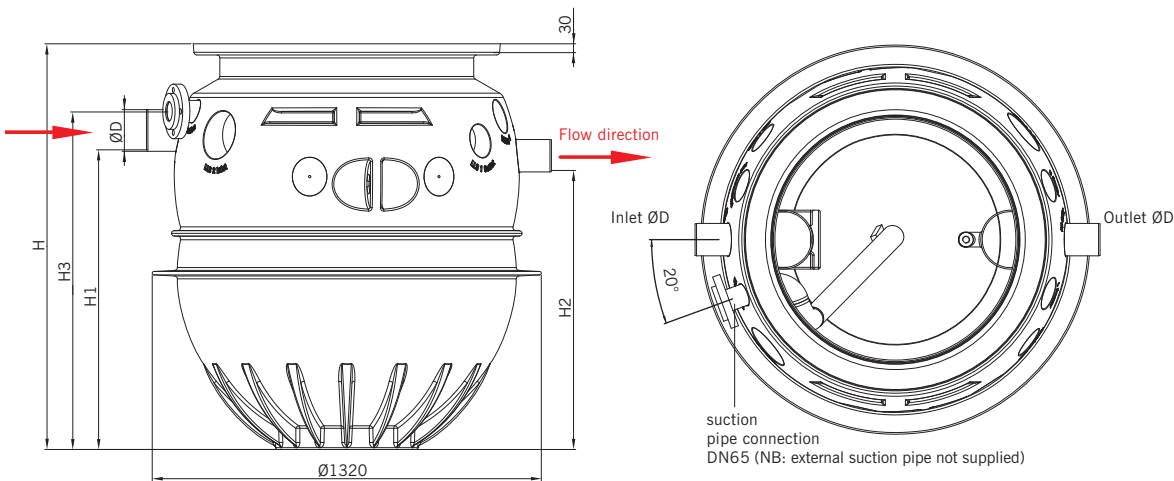

Nominal size	Spigot nominal size	Sludge storage volume (l)	Grease storage volume (l)	Total capacity (l)	ØD (mm)	H (mm)	H1 (mm)	H2 (mm)	H3 (mm)	Dry Weight (kg)	Product Ref
NS 2	DN 100	245	270	720	110	1377	1015	945	1147	66	3202.81.00
NS 2*	DN 100	460	270	930	110	1594	1235	1165	1364	81	3202.81.10
NS 4	DN 100	460	270	930	110	1594	1235	1165	1364	81	3204.81.00
NS 4*	DN 100	980	270	1465	110	2129	1745	1675	1899	92	3204.81.10
NS 5.5	DN 150	570	230	1465	160	2129	1745	1675	1899	95	3205.81.00
NS 5.5*	DN 150	1065	230	1960	160	2611	2226	2156	2381	111	3205.81.10
NS 7	DN 150	730	285	1675	160	2346	1960	1890	2116	111	3207.81.00
NS 8.5	DN 150	860	360	1900	160	2558	2172	2102	2328	118	3208.81.00
NS 10	DN 150	1005	415	2170	160	2828	2443	2373	2598	128	3210.81.00

*For abattoir and meat processing applications, select double sludge capacity models.

Accessories

- For all accessories please refer to pages 21 - 23



Top Section Load Class A15

- Load Class A15 access cover to BS EN 124
- 600mm clear opening access cover, single EPDM seal
- Concrete frame, cast iron cover
- Variable inlet invert position achieved by on-site trimming of sealed MDPE raising tube (supplied with options 3300.14.01 and 3300.14.02 only)

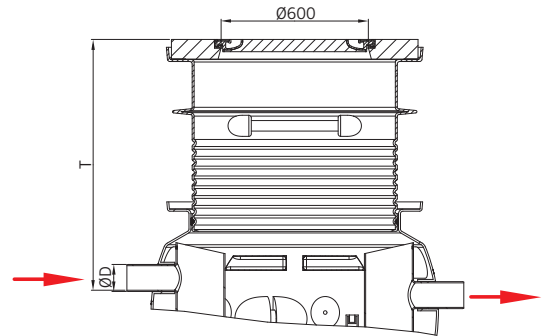

	NS 2 ST 200	NS 2 ST 400	NS 4 ST 400	NS 4 ST 800	NS 5.5 ST 550	NS 5.5 ST 1100	NS 7 ST 700	NS 8.5 ST 850	NS 10 ST 1000	Weight (kg)	Product Ref
T (mm)	420	420	420	420	445	445	445	445	445	145	3300.14.00
	720-1020	720-1020	720-1020	720-1020	745-1045	745-1045	745-1045	745-1045	745-1045	170	3300.14.01
	720-1985	720-1985	720-1985	720-1985	745-1855	745-1855	745-1640	745-1640	745-1640	193	3300.14.02

Top Section Load Class B125

- Load Class B125 access cover to BS EN 124
- 600mm clear opening access cover, single EPDM seal
- Concrete frame, cast iron cover
- Concrete adaptor plate Ø1000mm x 150mm deep
- Variable inlet invert position achieved by on-site trimming of sealed MDPE raising tube (supplied with options 3300.15.01 and 3300.15.02 only)

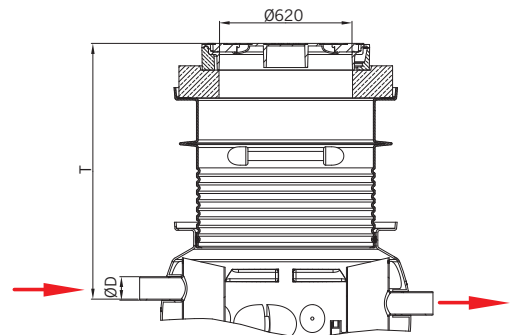

	NS 2 ST 200	NS 2 ST 400	NS 4 ST 400	NS 4 ST 800	NS 5.5 ST 550	NS 5.5 ST 1100	NS 7 ST 700	NS 8.5 ST 850	NS 10 ST 1000	Weight (kg)	Product Ref
T (mm)	585	585	585	585	610	610	610	610	610	282	3300.15.00
	885-1195	885-1195	885-1195	885-1195	910-1220	910-1220	910-1220	910-1220	910-1220	307	3300.15.01
	885-1985	885-1985	885-1985	885-1985	910-1855	910-1855	910-1640	910-1640	910-1640	330	3300.15.02



Top Section Load Class D400

- Load Class D400 access cover to BS EN 124
- 600mm clear opening access cover, single EPDM seal
- Concrete frame, cast iron cover
- Concrete adaptor plate Ø1000mm x 150mm deep
- Variable inlet invert position achieved by trimming of sealed MDPE raising tube
- Concrete load distribution plate Ø1500mm x 200mm deep to reduce on-site slab reinforcement (supplied with option 3300.16.00 only)

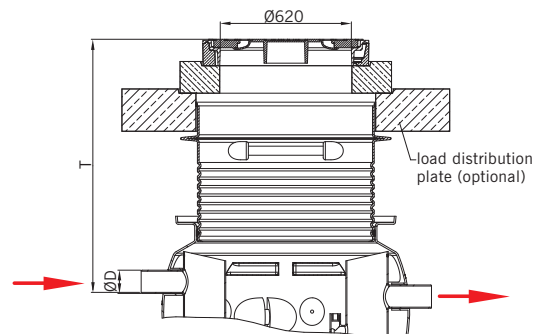

	NS 2 ST 200	NS 2 ST 400	NS 4 ST 400	NS 4 ST 800	NS 5.5 ST 550	NS 5.5 ST 1100	NS 7 ST 700	NS 8.5 ST 850	NS 10 ST 1000	Weight (kg)	Product Ref
T* (mm)	865-1985	865-1985	865-1765	865-1765	890-1855	890-1855	890-1640	890-1640	890-1640	330	3300.17.00
T** (mm)	865-1985	865-1985	865-1765	865-1765	890-1855	890-1855	890-1640	890-1640	890-1640	1030	3300.16.00

*without load distribution plate

**with load distribution plate

ACO Lipumax P-DM - High Extension Stage 2 - Technical Data



Product Details

- Corrosion-resistant MDPE construction – 50 year life guarantee
- Designed, tested and certified to BS EN 1825
- Roto-moulded ribbed construction prevents buoyancy in high water table locations
- Best suited in locations where odours from exposed access cover would be a nuisance
- Contents disposal to vacuum tanker via remote connection (3" Bauer connector supplied with product)
- High pressure internal cleaning system – Manual operation
- Nominal delivery pressure: 175 bar
- Clean cold water consumption: 13 l/minute
- High pressure pump located inside building – 3/4" cold water supply needed for pump and clean water re-fill
- Electrical supply: 3-phase 415V, 50 Hz, 16A, 3.9kW
- Adjustable inlet invert position
- Choice of Load Class A15, B125 and D400 600mm clear opening access covers to BS EN 124
- All access covers supplied with 3-point locking

Installation example shows ACO Lipumax P-DM NS 4 with Load Class B125 access cover

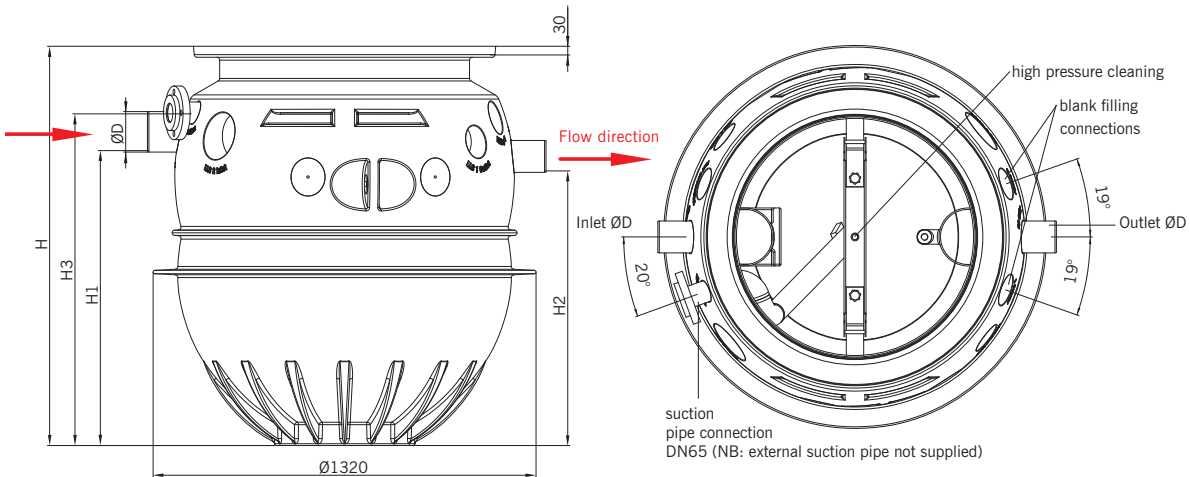

Nominal size	Spigot nominal size	Sludge storage volume (l)	Grease storage volume (l)	Total capacity (l)	ØD (mm)	H (mm)	H1 (mm)	H2 (mm)	H3 (mm)	Dry Weight (kg)	Product Ref
NS 2	DN 100	245	270	720	110	1377	1015	945	1147	119	3202.82.00
NS 2*	DN 100	460	270	930	110	1594	1235	1165	1364	134	3202.82.10
NS 4	DN 100	460	270	930	110	1594	1235	1165	1364	134	3204.82.00
NS 4*	DN 100	980	270	1465	110	2129	1745	1675	1899	145	3204.82.10
NS 5.5	DN 150	570	230	1465	160	2129	1745	1675	1899	148	3205.82.00
NS 5.5*	DN 150	1065	230	1960	160	2611	2226	2156	2381	164	3205.82.10
NS 7	DN 150	730	285	1675	160	2346	1960	1890	2116	164	3207.82.00
NS 8.5	DN 150	860	360	1900	160	2558	2172	2102	2328	171	3208.82.00
NS 10	DN 150	1005	415	2170	160	2828	2443	2373	2598	181	3210.82.00

*For abattoir and meat processing applications, select double sludge capacity models.

Accessories

■ For all accessories please refer to pages 21 - 23

Note: Lipumax P-DM requires high pressure hose, for options refer to page 22



Top Section Load Class A15

- Load Class A15 access cover to BS EN 124
- 600mm clear opening access cover, single EPDM seal
- Concrete frame, cast iron cover
- Variable inlet invert position achieved by on-site trimming of sealed MDPE raising tube (supplied with options 3300.14.01 and 3300.14.02 only)

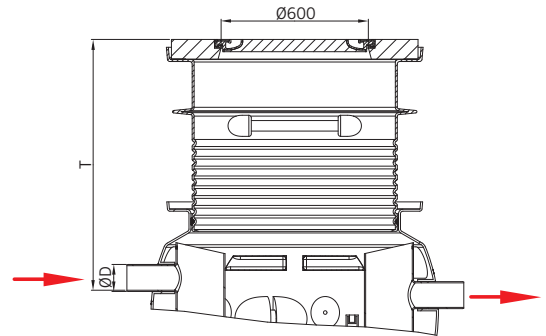

	NS 2 ST 200	NS 2 ST 400	NS 4 ST 400	NS 4 ST 800	NS 5.5 ST 550	NS 5.5 ST 1100	NS 7 ST 700	NS 8.5 ST 850	NS 10 ST 1000	Weight (kg)	Product Ref
T (mm)	420	420	420	420	445	445	445	445	445	145	3300.14.00
	720-1020	720-1020	720-1020	720-1020	745-1045	745-1045	745-1045	745-1045	745-1045	170	3300.14.01
	720-1985	720-1985	720-1985	720-1985	745-1855	745-1985	745-1640	745-1640	745-1640	193	3300.14.02

Top Section Load Class B125

- Load Class B125 access cover to BS EN 124
- 600mm clear opening access cover, single EPDM seal
- Concrete frame, cast iron cover
- Concrete adaptor plate Ø1000mm x 150mm deep
- Variable inlet invert position achieved by on-site trimming of sealed MDPE raising tube (supplied with options 3300.15.01 and 3300.15.02 only)

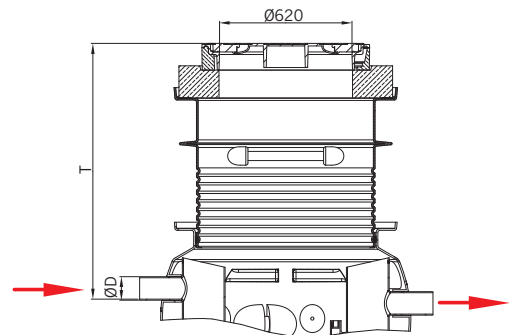

	NS 2 ST 200	NS 2 ST 400	NS 4 ST 400	NS 4 ST 800	NS 5.5 ST 550	NS 5.5 ST 1100	NS 7 ST 700	NS 8.5 ST 850	NS 10 ST 1000	Weight (kg)	Product Ref
T (mm)	585	585	585	585	610	610	610	610	610	282	3300.15.00
	885-1195	885-1195	885-1195	885-1195	910-1220	910-1220	910-1220	910-1220	910-1220	307	3300.15.01
	885-1985	885-1985	885-1985	885-1985	910-1855	910-1855	910-1640	910-1640	910-1640	330	3300.15.02

Top Section Load Class D400

- Load Class D400 access cover to BS EN 124
- 600mm clear opening access cover, single EPDM seal
- Concrete frame, cast iron cover
- Concrete adaptor plate Ø1000mm x 150mm deep
- Variable inlet invert position achieved via onsite trimming of sealed MDPE raising tube
- Concrete load distribution plate Ø1500mm x 200mm deep to reduce on-site slab reinforcement (supplied with option 3300.16.00 only)

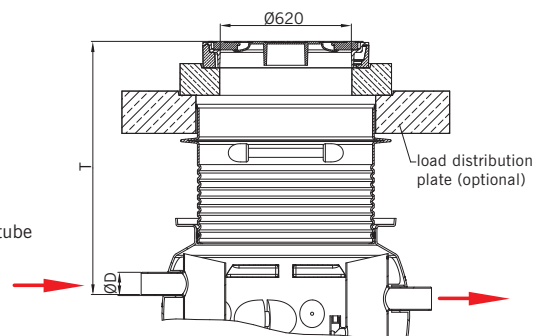

	NS 2 ST 200	NS 2 ST 400	NS 4 ST 400	NS 4 ST 800	NS 5.5 ST 550	NS 5.5 ST 1100	NS 7 ST 700	NS 8.5 ST 850	NS 10 ST 1000	Weight (kg)	Product Ref
T* (mm)	865-1985	865-1985	865-1765	865-1765	890-1855	890-1855	890-1640	890-1640	890-1640	330	3300.17.00
T** (mm)	865-1985	865-1985	865-1765	865-1765	890-1855	890-1855	890-1640	890-1640	890-1640	1030	3300.16.00

*without load distribution plate

**with load distribution plate



ACO Lipumax P-DA Premium - Extention Stage 2 - Technical Data



Product Details

- Corrosion-resistant MDPE construction – 50 year life guarantee
- Designed, tested and certified to BS EN 1825
- Roto-moulded ribbed construction prevents buoyancy in high water table locations
- Best situated in locations where odours from exposed access cover would be a nuisance
- Contents disposal to vacuum tanker via remote connection (3" Bauer connector supplied with product)
- High pressure internal cleaning system – Automated program controlled operation
- Nominal delivery pressure: 175 bar
- Clean cold water consumption: 13 l/minute
- High pressure pump located inside building – 3/4" cold water supply needed for pump and clean water re-fill
- Electrical supply: 3-phase 415V, 50 Hz, 16A, 3.9kW
- Adjustable inlet invert position
- Choice of Load Class A15, B125 and D400 600mm clear opening access covers to BS EN 124
- All access covers supplied with 3-point locking

Installation example shows ACO Lipumax P-A NS 4 with Load Class B125 access cover

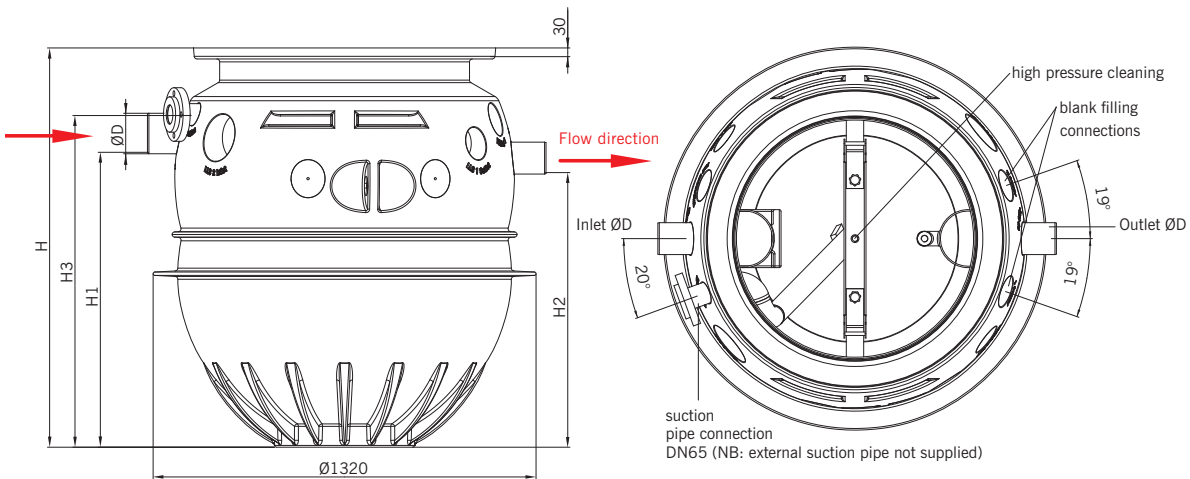

Nominal size	Spigot nominal size	Sludge storage volume (l)	Grease storage volume (l)	Total capacity (l)	ØD (mm)	H (mm)	H1 (mm)	H2 (mm)	H3 (mm)	Dry Weight (kg)	Product Ref
NS 2	DN 100	245	270	720	110	1377	1015	945	1147	123	3202.83.00
NS 2*	DN 100	460	270	930	110	1594	1235	1165	1364	138	3202.83.10
NS 4	DN 100	460	270	930	110	1594	1235	1165	1364	138	3204.83.00
NS 4*	DN 100	980	270	1465	110	2129	1745	1675	1899	149	3204.83.10
NS 5.5	DN 150	570	230	1465	160	2129	1745	1675	1899	152	3205.83.00
NS 5.5*	DN 150	1065	230	1960	160	2611	2226	2156	2381	167	3205.83.10
NS 7	DN 150	730	285	1675	160	2346	1960	1890	2116	168	3207.83.00
NS 8.5	DN 150	860	360	1900	160	2558	2172	2102	2328	175	3208.83.00
NS 10	DN 150	1005	415	2170	160	2828	2443	2373	2598	185	3210.83.00

*For abattoir and meat processing applications, select double sludge capacity models.

Accessories

■ For all accessories please refer to pages 21 - 23

Note: Lipumax P-DA requires high pressure hose, for options refer to page 22



Top Section Load Class A15

- Load Class A15 access cover to BS EN 124
- 600mm clear opening access cover, single EPDM seal
- Concrete frame, cast iron cover
- Variable inlet invert position achieved by on-site trimming of sealed MDPE raising tube (supplied with options 3300.14.01 and 3300.14.02 only)

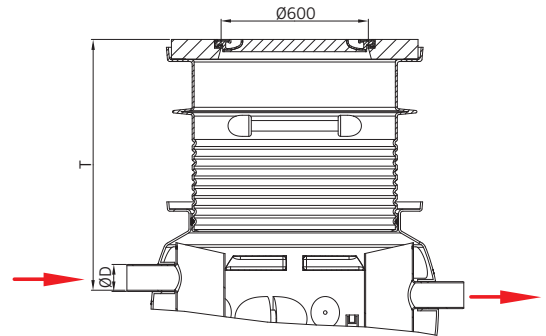

	NS 2 ST 200	NS 2 ST 400	NS 4 ST 400	NS 4 ST 800	NS 5.5 ST 550	NS 5.5 ST 1100	NS 7 ST 700	NS 8.5 ST 850	NS 10 ST 1000	Weight (kg)	Product Ref
T (mm)	420	420	420	420	445	445	445	445	445	145	3300.14.00
	720-1020	720-1020	720-1020	720-1020	745-1045	745-1045	745-1045	745-1045	745-1045	170	3300.14.01
	720-1985	720-1985	720-1985	720-1985	745-1855	745-1985	745-1640	745-1640	745-1640	193	3300.14.02

Top Section Load Class B125

- Load Class B125 access cover to BS EN 124
- 600mm clear opening access cover, single EPDM seal
- Concrete frame, cast iron cover
- Concrete adaptor plate Ø1000mm x 150mm deep
- Variable inlet invert position achieved by on-site trimming of sealed MDPE raising tube (supplied with options 3300.15.01 and 3300.15.02 only)

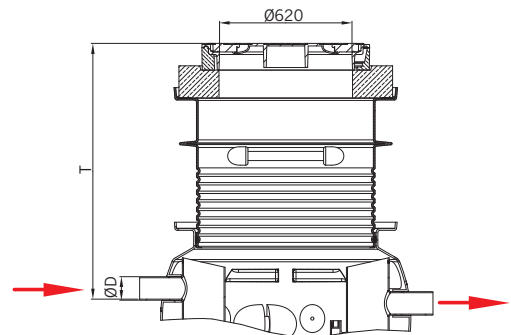

	NS 2 ST 200	NS 2 ST 400	NS 4 ST 400	NS 4 ST 800	NS 5.5 ST 550	NS 5.5 ST 1100	NS 7 ST 700	NS 8.5 ST 850	NS 10 ST 1000	Weight (kg)	Product Ref
T (mm)	585	585	585	585	610	610	610	610	610	282	3300.15.00
	885-1195	885-1195	885-1195	885-1195	910-1220	910-1220	910-1220	910-1220	910-1220	307	3300.15.01
	885-1985	885-1985	885-1985	885-1985	910-1855	910-1855	910-1640	910-1640	910-1640	330	3300.15.02

Top Section Load Class D400

- Load Class D400 access cover to BS EN 124
- 600mm clear opening access cover, single EPDM seal
- Concrete frame, cast iron cover
- Concrete adaptor plate Ø1000mm x 150mm deep
- Variable inlet invert position achieved via onsite trimming of sealed MDPE raising tube
- Concrete load distribution plate Ø1500mm x 200mm deep to reduce on-site slab reinforcement (supplied with option 3300.16.00 only)

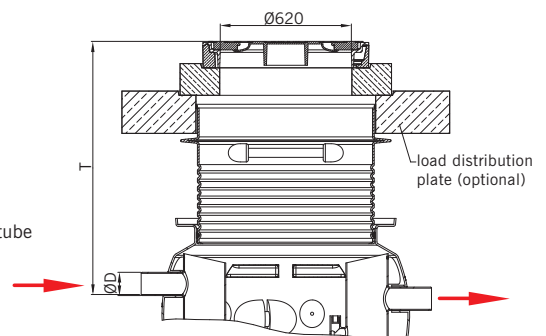

	NS 2 ST 200	NS 2 ST 400	NS 4 ST 400	NS 4 ST 800	NS 5.5 ST 550	NS 5.5 ST 1100	NS 7 ST 700	NS 8.5 ST 850	NS 10 ST 1000	Weight (kg)	Product Ref
T* (mm)	865-1985	865-1985	865-1765	865-1765	890-1855	890-1855	890-1640	890-1640	890-1640	330	3300.17.00
T** (mm)	865-1985	865-1985	865-1765	865-1765	890-1855	890-1855	890-1640	890-1640	890-1640	1030	3300.16.00

*without load distribution plate

**with load distribution plate



ACO Lipmax P Product Range - Accessories

Product	Description	Dimensions	Weight (kg)	Product Ref
	<p>Concrete support rings Fit between raising tube and separator cover plate to Increase inlet invert depth. Can be stacked.</p>	Ø865 x 60mm	50	8700.20.00
		Ø865 x 80mm	60	8700.20.10
		Ø865 x 100mm	70	8700.20.20
	<p>Grease level sensor Monitors grease thickness. Suitable for liquid oils and hardening fats. Controller displays 50% and 80% grease capacity with output to Building Management Systems. Electrical supply: 230V AC, 50Hz, 12W.</p>	Cable length: 10m	2	3300.11.70
		Cable length: 20m	2.5	3300.11.71
		Cable length: 30m	3.0	3300.11.72
	<p>Sampling pump Allows easy collection of samples from sampling shaft. Complete with manual pump, suction coupling and connecting hose. Suitable for maximum inlet invert 3000mm.</p>		2.4	8800.00.10
	<p>Sampling shaft MDPE below ground sampling shaft for downstream location of separator. Complete with D400 single sealed Ø450mm clear opening cover to BS EN 124. Variable inlet invert range: 575 – 1300mm.</p>	Ø110mm for NS 2 - 4 with outlet 153mm below invert	119.9	3300.13.10
		Ø110mm for NS 2 – 4 with outlet 33mm below invert	119.9	3300.13.11
		Ø160mm for NS 5.5 – 10 with outlet 159mm below invert	120.2	3300.13.20
		Ø160mm for NS 5.5 – 10 with outlet 75mm below invert	120.2	3300.13.21
	<p>Sampling shaft MDPE below ground sampling shaft for downstream location of separator. Complete with concrete load distribution plate and D400 single sealed Ø450mm clear opening cover to BS EN 124. Variable inlet invert range: 575 – 1300mm.</p>	Ø110mm for NS 2 - 4 with outlet 153mm below invert	590	3300.13.15
		Ø110mm for NS 2 – 4 with outlet 33mm below invert	590	3300.13.16
		Ø160mm for NS 5.5 – 10 with outlet 159mm below invert	520	3300.13.25
		Ø160mm for NS 5.5 – 10 with outlet 75mm below invert	520	3300.13.26

Product	Description	Dimensions	Weight (kg)	Product Ref
	<p>Disposal shaft</p> <p>MDPE below ground disposal shaft for direct coupling to vacuum disposal tanker. Complete with concrete load distribution plate and D400 access cover to BS EN 124.</p>		520	3300.30.01
	<p>MDPE Sampling shaft extension tube</p> <p>Sampling shaft invert extension range 100 to 650mm. Can be cut onsite in 45mm intervals.</p>	Maximum height: 650mm	11	3300.13.00
	<p>High pressure hose</p> <p>For use with Lipumax P-DM and P-DA. Connects high pressure pump to internal cleaning head in separator body.</p>	Length: 10m	10	0150.33.62
		Length: 20m	19	0150.33.63
		Length: 30m	28	0150.33.64
	<p>Wall mounted connection box</p> <p>For use with Lipumax P-D and P-DM. Manufactured from 304 grade stainless steel to house remote disposal connection.</p>	Size: 370(W) x 330(H) x 250(D)mm	7.9	7601.80.22
	<p>Flush mounted frame</p> <p>For use with wall mounted connection Box 7601.80.22. Manufactured from 304 grade stainless steel.</p>	Size: 421(W) x 381(H) x 25(D)mm	1.1	7601.80.23



Product	Description	Dimensions	Weight (kg)	Product Ref
	<p>Wall mounted connection box For use with Lipumax P-DA. Manufactured from 304 grade stainless steel to house remote disposal connection.</p>	<p>Size: 500(W) x 500(H) x 160(D)mm</p>	<p>15</p>	<p>7601.80.20</p>
	<p>Flush mounted frame For use with wall mounted connection Box 7601.80.20. Manufactured from 304 grade stainless steel.</p>	<p>Size: 565(W) x 565(H) x 15(D)mm</p>	<p>1.3</p>	<p>7601.80.21</p>
	<p>Disposal tanker adaptor For use with Lipumax P-D, P-DM and P-DA. Storz 75-B to Bauer 3" male connector adaptor set with clamp.</p>		<p>2.5</p>	<p>105860</p>
	<p>Vent sealing ring Allows sealing of Ø110mm vent connections to separator body (if required).</p>		<p>0.2</p>	<p>0150.34.32</p>

ACO ECO-FPI Product Range Overview - Features and Benefits

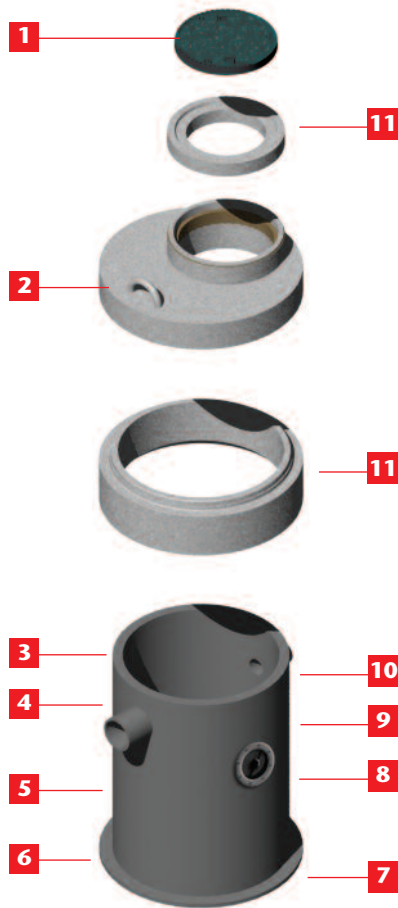

- 1** Load Class D400 single sealed cast iron access cover with concrete cover plate and 600mm clear opening for easy servicing access.
- 2** Lifting hooks cast in to assist handling on site.
- 3** Separator assembly is a structural element in its own right accommodating D400 Load Class without additional concrete support or reinforcement. Maximum installation speed with minimal installation cost.
- 4** Available with Ø110mm or Ø160mm inlet/outlet spigots. Integrated sampling station in outlet.
- 5** Robust construction withstands site handling, concrete pour and groundwater pressures.
- 6** Flat base ensures high stability during site movement, storage and installation.
- 7** Concrete anchor flanges prevent buoyancy in high water table locations.
- 8** Optional factory fitted direct built-in suction pipe connection for odourless contents disposal.
- 9** Lightweight body construction for easy handling.
- 10** Highly corrosion resistant spiral-wound twin-walled high-density polyethylene (HDPE) construction for the ultimate in strength.
- 11** Available with fine and course adjustment raising rings.
- 12** Optional factory fitted base plate reinforcement for installations where water table exceeds 1m above separator baseplate.

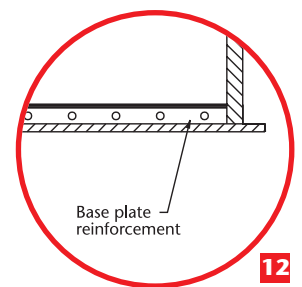
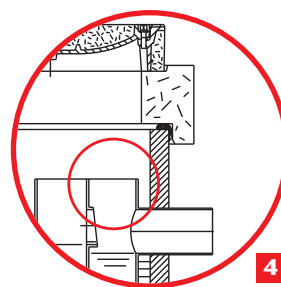
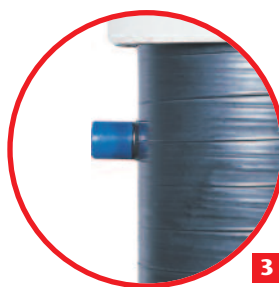

NBS Specification Clause Reference

For relevant NBS specification, refer to NBS section R12 Below Ground Drainage, Clause 630 Grease Traps/Converters and insert the appropriate model reference.

ACO ECO-FPI - Technical Data

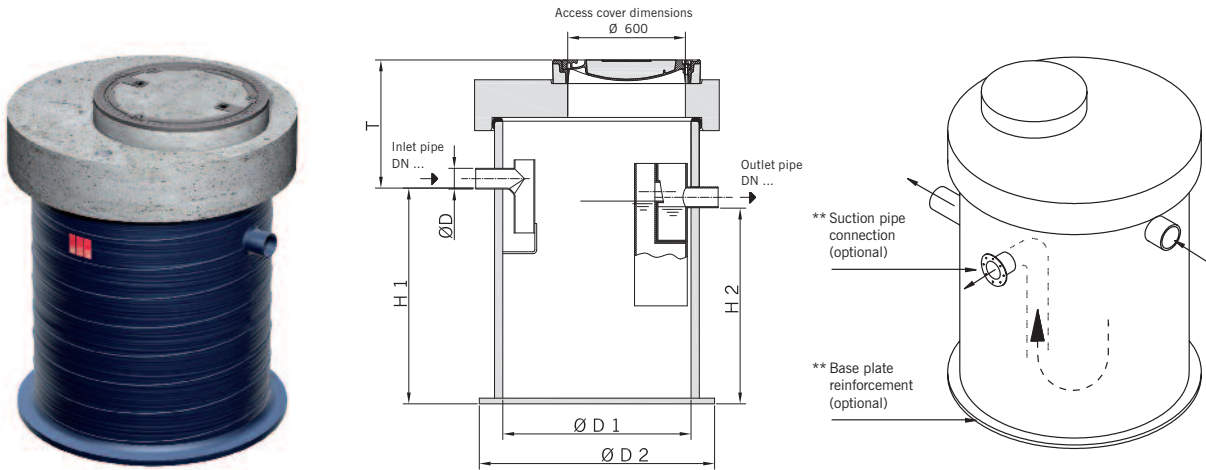

Nominal size	Sludge storage volume (l)	Grease storage volume (l)	Total capacity (l)	H1 (l)	H2 (l)	ØD (mm)	ØD1 (mm)	ØD2 (mm)	T
NS 1	100	120	615	885	785	110	1000	1250	695
NS 1*	200	120	715	1010	910	110	1000	1250	570
NS 2	200	120	715	1010	910	110	1000	1250	570
NS 2*	400	120	915	1265	1165	110	1000	1250	560
NS 3	300	120	815	1140	1040	110	1000	1250	685
NS 3*	600	120	1115	1520	1420	110	1000	1250	815
NS 4	400	160	915	1265	1165	110	1000	1250	560
NS 4*	800	160	1315	1775	1675	110	1000	1250	560
NS 7	700	400	1950	1205	1105	160	1500	1800	650
NS 7*	1400	400	2660	1605	1505	160	1500	1800	650
NS 10	1000	400	2250	1370	1270	160	1500	1800	685
NS 10*	2000	400	3250	1940	1840	160	1500	1800	665

HDPE Body Weight (kg)	Concrete Cover Weight (kg)	Access Cover Weight (kg)	System Assembly Dry Weight (kg)	Product Ref
110	450	150	710	704901
110	450	150	710	704905
110	450	150	710	704909
125	450	150	725	704913
125	450	150	725	704917
160	450	150	760	704921
125	450	150	725	704925
160	450	150	760	704929
240	1150	150	1540	704933
310	1150	150	1610	704937
275	1150	150	1575	704941
365	1150	150	1665	704945

*For abattoir and meat processing applications, select double sludge capacity models.
 **For factory fitted suction pipe connection or baseplate reinforcement models please contact the ACO Building Drainage team on 01462 816666 or email abdinfo@aco.co.uk

Accessories

■ For all accessories please refer to page 26

ACO ECO-FPI Product Range - Accessories

Product	Description	Dimensions	Weight (kg)	Product Ref
	<p>Fine adjustment raising ring Can only be used up to a maximum of 200mm. For greater depth, use coarse adjustment raising ring shown below</p>	Ø865 x 60mm	50	700821
		Ø865 x 80mm	60	700822
		Ø865 x 100mm	70	700823
	<p>Coarse adjustment raising ring For use with ECO-FPI nominal size separators 1, 2, 3, & 4</p>	Ø1000 x 250mm	240	700904
		Ø1000 x 500mm	500	700906
		Ø1000 x 1000mm	1000	700907
	<p>Coarse adjustment raising ring For use with ECO-FPI nominal size separators 7 & 10</p>	Ø1500 x 250mm	480	700913
		Ø1500 x 500mm	931	700915

ACO ECO-JET and HYDROJET Product Range Overview



ECO-JET Split Design

- Ideal where access is problematic, i.e. stairs, narrow corridors etc
- Splits into 3 lightweight components
- Easy to assemble
- Access covers removable for servicing
- Direct suction option available to reduce odours during servicing



ECO-JET Oval

- Lowest cost option free standing grease separator
- Oval design for convenient installation
- Access covers removable for servicing
- Direct suction option available to reduce odours during servicing
- Optional retro-fit upgrades to HYDROJET Oval specification



HYDROJET Oval

- Advanced separator design
- Direct suction facility prevents odours during servicing
- Grease level inspection window
- High pressure (175 bar) internal cleaning facility
- Manually operated ball valve cold water fill facility
- Optional disposal pump
- Fully automated control option



HYDROJET Round

- Features as HYDROJET Oval
- High hydraulic capacity - up to NS 20
- Circular tank easily dismantled into separate components for convenient installation



NBS Specification Clause Reference

For relevant NBS specification, refer to NBS section R12 Below Ground Drainage, Clause 630 Grease Traps/Converters and insert the appropriate model reference.

ACO ECO-JET-GD Split Design Series - Technical Data

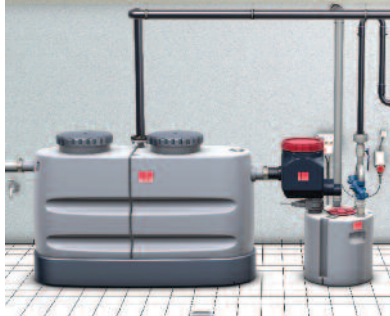

Product Details

- Manufactured from corrosion resistant polyethylene for use inside buildings that are free from frost
- Ideal for refurbishment projects where clear access for installation is limited
- Access covers removable for servicing
- Splits into 3 lightweight components
- Easy to assemble
- Direct suction extraction option available to reduce odours during contents disposal and servicing

Installation example shows ACO NS4 ECO-JET-G NS 4 with optional downstream sampling station and lifting plant.

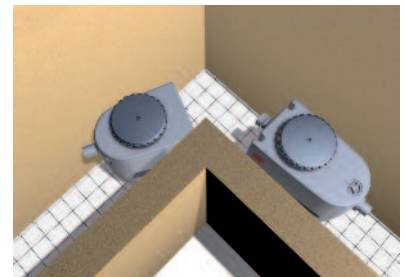
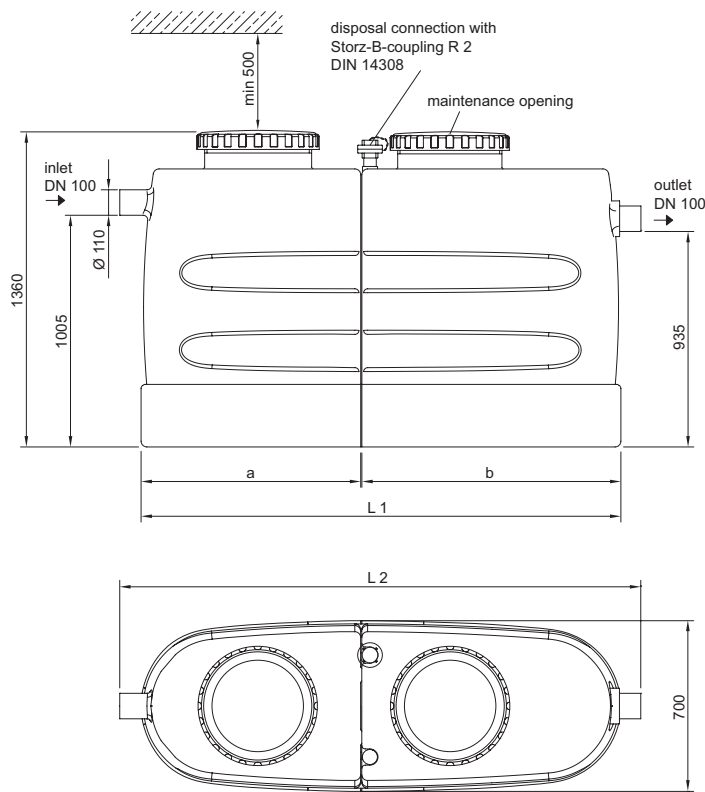

28
■

Nominal size	Sludge storage volume (l)	Grease storage volume (l)	Total capacity (l)	L1 (mm)	L2 (mm)	a (mm)	b (mm)	Dry Weight (kg)	Full Weight (kg)	Product Ref
NS 2	210	80	480	1180	1360	510	660	75	555	3802.00.00
NS 2*	210	80	480	1180	1360	510	660	75	555	3802.50.00
NS 4	420	160	880	2070	2250	945	1115	115	995	3804.00.00
NS 4*	420	160	880	2070	2250	945	1115	115	995	3804.50.00

* With direct suction extraction

Accessories

- For all accessories please refer to page 43

ACO ECO-JET-O and HYDROJET-O Series

Product Details

- ECO-JET-O and the more sophisticated HYDROJET-O oval grease separators are one piece rotationally moulded units manufactured from corrosion resistant polyethylene for use inside buildings that are free from frost.
- Easily upgraded in various stages to more advanced models to suit operational requirements.
- Rugged and durable lightweight corrosion resistant polyethylene construction
- Wide range of size availability to optimise space requirement

ECO-JET nomenclature

- O** – Oval - basic model
- OD** - As O with direct suction facility

HYDROJET nomenclature

- OS** - Direct suction and high pressure internal cleaning under manual control. Grease inspection window
- OSE** - As OS with manually controlled disposal pump
- OA** - As OS but with automatic program control
- OAE** - As OA but with disposal pump under automatic control

Plan View

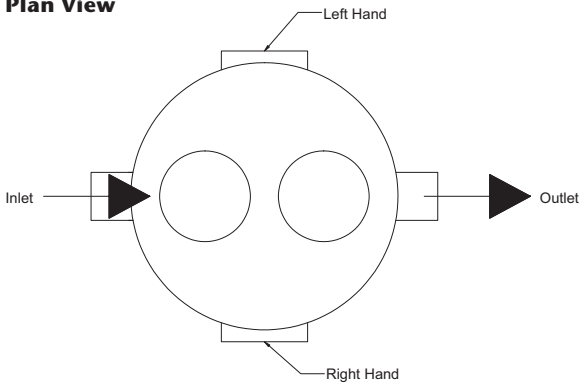

Note - disposal pump required when vertical suction lift exceeds 6m.

Separators fitted with a viewing window can be either right hand or left hand operation and is defined in the diagram adjacent.



Installation example shows HYDROJET-OAE with optional sampling station and lifting plant.

ACO ECO-JET 0 (Basic Model) - Technical Data



Product Details

- Disposal and cleaning via open lids (potential odour emissions)
- Upgradeable to Stages 1 to 3

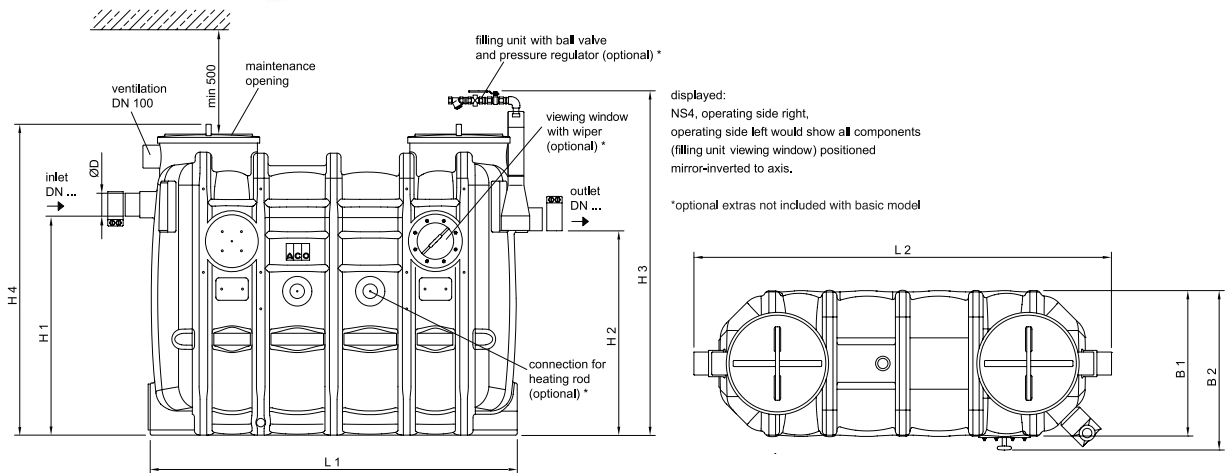

Nominal size	Spigot nominal size	Sludge storage volume (l)	Grease storage volume (l)	Total capacity (l)	Dry Weight (kg)	Full Weight (kg)	Product Ref
NS 1	DN 100	106	100	320	62	382	3551.34.00
NS 2	DN 100	210	100	440	70	510	3552.34.00
NS 3	DN 100	300	150	630	80	710	3553.34.00
NS 4	DN 100	400	200	830	95	925	3554.34.00
NS 5.5	DN 150	725	360	1430	170	1600	3555.34.00
NS 7	DN 150	800	400	1600	187	1787	3557.34.00
NS 8.5	DN 150	940	475	1900	208	2108	3558.34.00
NS 10	DN 150	1000	520	2000	220	2220	3560.34.00

Nominal size	Dimensions (mm)									Product Ref
	L1	L2	H1	H2	H3	H4	B1	B2	ØD	
NS 1	1100	1300	830	760	1480	1300	700	770	110	3551.34.00
NS 2	1100	1300	1055	985	1680	1500	700	770	110	3552.34.00
NS 3	1450	1650	1055	985	1680	1500	700	770	110	3553.34.00
NS 4	1760	2000	1055	985	1680	1500	700	770	110	3554.34.00
NS 5.5	1760	2000	1250	1180	1880	1700	950	1020	160	3555.34.00
NS 7	1960	2200	1250	1180	1880	1700	950	1020	160	3557.34.00
NS 8.5	2250	2485	1250	1180	1880	1700	950	1020	160	3558.34.00
NS 10	2450	2690	1250	1180	1880	1700	950	1020	160	3560.34.00

Accessories

- For all accessories please refer to page 43

ACO ECO-JET OD Extension Stage 1 - Technical Data



Product Details

- Odour-free disposal via direct suction pipe
- Manual internal cleaning via open lid (minor odour emissions)
- Upgradeable to Stages 2 and 3

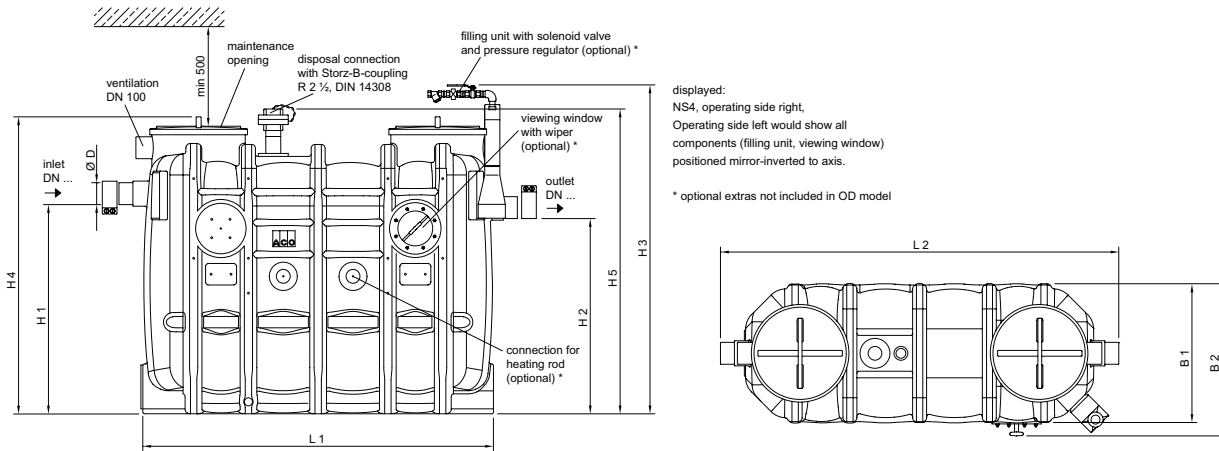

Nominal size	Spigot nominal size	Sludge storage volume (l)	Grease storage volume (l)	Total capacity (l)	Dry Weight (kg)	Full Weight (kg)	Product Ref
NS 1	DN 100	106	100	320	68	388	3551.64.00
NS 2	DN 100	210	100	440	75	515	3552.64.00
NS 3	DN 100	300	150	630	85	715	3553.64.00
NS 4	DN 100	400	200	830	100	930	3554.64.00
NS 5.5	DN 150	725	360	1430	175	1605	3555.64.00
NS 7	DN 150	800	400	1600	193	1793	3557.64.00
NS 8.5	DN 150	940	475	1900	214	2114	3558.64.00
NS 10	DN 150	1000	520	2000	226	2226	3560.64.00

Nominal size	Dimensions (mm)									Product Ref
	L1	L2	H1	H2	H3	H4	B1	B2	ØD	
NS 1	1100	1300	830	760	1480	1300	700	770	110	3551.64.00
NS 2	1100	1300	1055	985	1680	1500	700	770	110	3552.64.00
NS 3	1450	1650	1055	985	1680	1500	700	770	110	3553.64.00
NS 4	1760	2000	1055	985	1680	1500	700	770	110	3554.64.00
NS 5.5	1760	2000	1250	1180	1880	1700	950	1020	160	3555.64.00
NS 7	1960	2200	1250	1180	1880	1700	950	1020	160	3557.64.00
NS 8.5	2250	2485	1250	1180	1880	1700	950	1020	160	3558.64.00
NS 10	2450	2690	1250	1180	1880	1700	950	1020	160	3560.64.00

Accessories

- For all accessories please refer to page 43



ACO ECO-JET OS Extension Stage 2 - Technical Data



Product Details

- Manually controlled odour-free disposal and cleaning via direct suction and high pressure (175 bar) internal cleaning system
- Supplied with viewing window and manually operated ball valve for clean water fill
- Upgradeable to Stage 3 and disposal pump

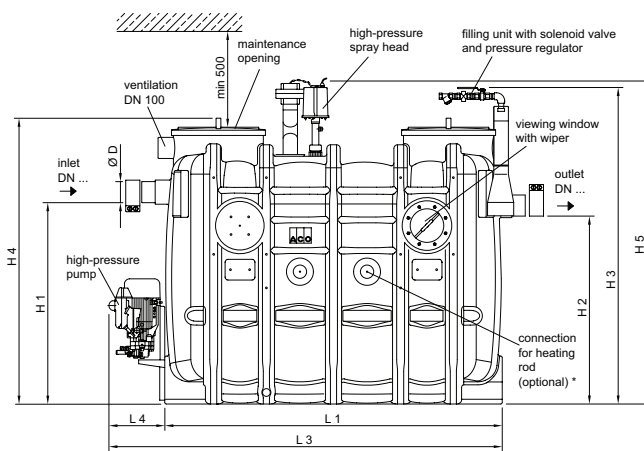

displayed:
NS4, operating side right.
operating side left would show all components
(disposal connection, filling unit, viewing window)
positioned mirror-inverted to axis.

* optional extras not included in OS model

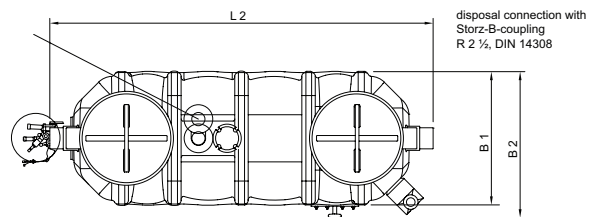

Nominal size	Spigot nominal size	Sludge storage volume (l)	Grease storage volume (l)	Total capacity (l)	Dry Weight (kg)	Full Weight (kg)	Product Ref Left Hand	Product Ref Right Hand
NS 1	DN 100	106	100	320	95	415	3571.74.41	3571.74.31
NS 2	DN 100	210	100	440	100	540	3572.74.41	3572.74.31
NS 3	DN 100	300	150	630	120	750	3573.74.41	3573.74.31
NS 4	DN 100	400	200	830	135	965	3574.74.41	3574.74.31
NS 5.5	DN 150	725	360	1430	206	1636	3575.74.41	3575.74.31
NS 7	DN 150	800	400	1600	223	1823	3577.74.41	3577.74.31
NS 8.5	DN 150	940	475	1900	243	2143	3578.74.41	3578.74.31
NS 10	DN 150	1000	520	2000	255	2255	3580.74.41	3580.74.31

Nominal size	Dimensions (mm)												Product Ref Left Hand	Product Ref Right Hand
	L1	L2	L3	L4	H1	H2	H3	H4	H5	B1	B2	ØD		
NS 1	1100	1300	1400	300	830	760	1480	1300	1500	700	770	110	3571.74.41	3571.74.31
NS 2	1100	1300	1400	300	1055	985	1680	1500	1700	700	770	110	3572.74.41	3572.74.31
NS 3	1450	1650	1750	300	1055	985	1680	1500	1700	700	770	110	3573.74.41	3573.74.31
NS 4	1760	2000	2060	300	1055	985	1680	1500	1700	700	770	110	3574.74.41	3574.74.31
NS 5.5	1760	2000	2060	300	1250	1180	1880	1700	1900	950	1020	160	3575.74.41	3575.74.31
NS 7	1960	2200	2260	300	1250	1180	1880	1700	1900	950	1020	160	3577.74.41	3577.74.31
NS 8.5	2250	2485	2550	300	1250	1180	1880	1700	1900	950	1020	160	3578.74.41	3578.74.31
NS 10	2450	2690	2750	300	1250	1180	1880	1700	1900	950	1020	160	3580.74.41	3580.74.31

Accessories

- For all accessories please refer to page 43

ACO HYDROJET OSE Extension Stage 2 - Technical Data



Product Details

- As HYDROJET OS with manually controlled disposal pump (required when vertical height exceeds 6 metres)
- Upgradeable to Stage 3

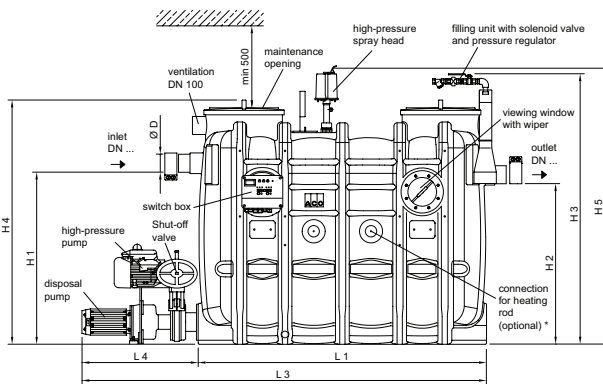

displayed:
NS4, operating side right,
operating side left would show all
components (disposal connection, filling
unit, viewing window, shut-off valve,
switch box) positioned mirror-inverted to axis

* optional extras not included is OSE model

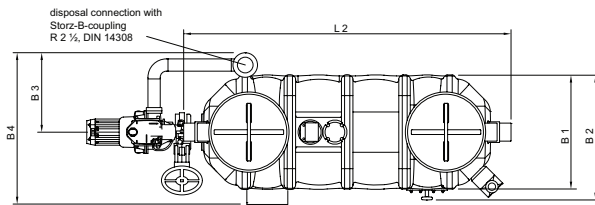

Nominal size	Spigot nominal size	Sludge storage volume (l)	Grease storage volume (l)	Total capacity (l)	Dry Weight (kg)	Full Weight (kg)	Product Ref Left Hand	Product Ref Right Hand
NS 1	DN 100	106	100	320	177	497	3571.84.41	3571.84.31
NS 2	DN 100	210	100	440	182	622	3572.84.41	3572.84.31
NS 3	DN 100	300	150	630	194	824	3573.84.41	3573.84.31
NS 4	DN 100	400	200	830	210	1040	3574.84.41	3574.84.31
NS 5.5	DN 150	725	360	1430	286	1716	3575.84.41	3575.84.31
NS 7	DN 150	800	400	1600	305	1905	3577.84.41	3577.84.31
NS 8.5	DN 150	940	475	1900	325	2225	3578.84.41	3578.84.31
NS 10	DN 150	1000	520	2000	337	2337	3580.84.41	3580.84.31

Nominal size	Dimensions (mm)														Product Ref Left Hand	Product Ref Right Hand
	L1	L2	L3	L4	H1	H2	H3	H4	H5	B1	B2	B3	B4	ØD		
NS 1	1100	1300	1800	700	830	760	1480	1300	1500	700	770	500	930	110	3571.84.41	3571.84.31
NS 2	1100	1300	1800	700	1055	985	1680	1500	1700	700	770	500	930	110	3572.84.41	3572.84.31
NS 3	1450	1650	2150	700	1055	985	1680	1500	1700	700	770	500	930	110	3573.84.41	3573.84.31
NS 4	1760	2000	2460	700	1055	985	1680	1500	1700	700	770	500	930	110	3574.84.41	3574.84.31
NS 5.5	1760	2000	2460	700	1250	1180	1880	1700	1900	950	1020	625	1180	160	3575.84.41	3575.84.31
NS 7	1960	2200	2660	700	1250	1180	1880	1700	1900	950	1020	625	1180	160	3577.84.41	3577.84.31
NS 8.5	2250	2485	2950	700	1250	1180	1880	1700	1900	950	1020	625	1180	160	3578.84.41	3578.84.31
NS 10	2450	2690	3150	700	1250	1180	1880	1700	1900	950	1020	625	1180	160	3580.84.41	3580.84.31

Accessories

- For all accessories please refer to page 43



ACO HYDROJET OA Extension Stage 3 - Technical Data



Product Details

- Programme controlled odour-free disposal and cleaning via direct suction and high pressure (175 bar) internal cleaning system
- Supplied with viewing window and automatically operated solenoid valve for clean water fill
- Upgradeable with disposal pump

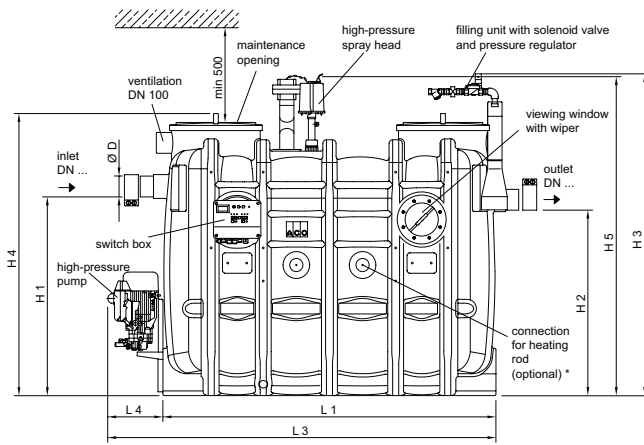

displayed:
NS4, operating side right.
operating side left would show all components
(disposal connection, filling unit, viewing window
switch box) positioned mirror-inverted to axis.

* Optional extras not included in OSE model

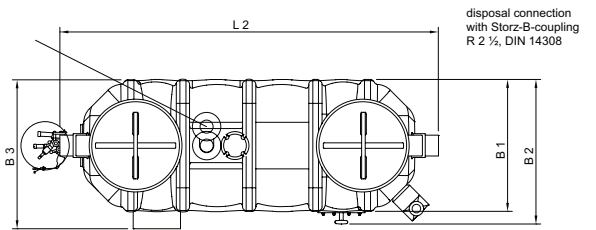

Nominal size	Spigot nominal size	Sludge storage volume (l)	Grease storage volume (l)	Total capacity (l)	Dry Weight (kg)	Full Weight (kg)	Product Ref Left Hand	Product Ref Right Hand
NS 1	DN 100	106	100	320	100	420	3551.74.42	3551.74.32
NS 2	DN 100	210	100	440	105	545	3552.74.42	3552.74.32
NS 3	DN 100	300	150	630	120	750	3553.74.42	3553.74.32
NS 4	DN 100	400	200	830	135	965	3554.74.42	3554.74.32
NS 5.5	DN 150	725	360	1430	210	1640	3555.74.42	3555.74.32
NS 7	DN 150	800	400	1600	226	1826	3557.74.42	3557.74.32
NS 8.5	DN 150	940	475	1900	247	2147	3558.74.42	3558.74.32
NS 10	DN 150	1000	520	2000	259	2259	3560.74.42	3560.74.32

Nominal size	Dimensions (mm)												Product Ref Left Hand	Product Ref Right Hand	
	L1	L2	L3	L4	H1	H2	H3	H4	H5	B1	B2	B3			ØD
NS 1	1100	1300	1400	300	830	760	1510	1300	1500	700	770	800	110	3551.74.42	3551.74.32
NS 2	1100	1300	1400	300	1055	985	1710	1500	1700	700	770	800	110	3552.74.42	3552.74.32
NS 3	1450	1650	1750	300	1055	985	1710	1500	1700	700	770	800	110	3553.74.42	3553.74.32
NS 4	1760	2000	2060	300	1055	985	1710	1500	1700	700	770	800	110	3554.74.42	3554.74.32
NS 5.5	1760	2000	2060	300	1250	1180	1910	1700	1900	950	1020	1050	160	3555.74.42	3555.74.32
NS 7	1960	2200	2260	300	1250	1180	1910	1700	1900	950	1020	1050	160	3557.74.42	3557.74.32
NS 8.5	2250	2485	2550	300	1250	1180	1910	1700	1900	950	1020	1050	160	3558.74.42	3558.74.32
NS 10	2450	2690	2750	300	1250	1180	1910	1700	1900	950	1020	1050	160	3560.74.42	3560.74.32

Accessories

- For all accessories please refer to page 43

ACO HYDROJET OAE Extension Stage 3 - Technical Data



Product Details

- As HYDROJET OA with automatically actuated disposal pump (required when vertical height exceeds 6 metres)

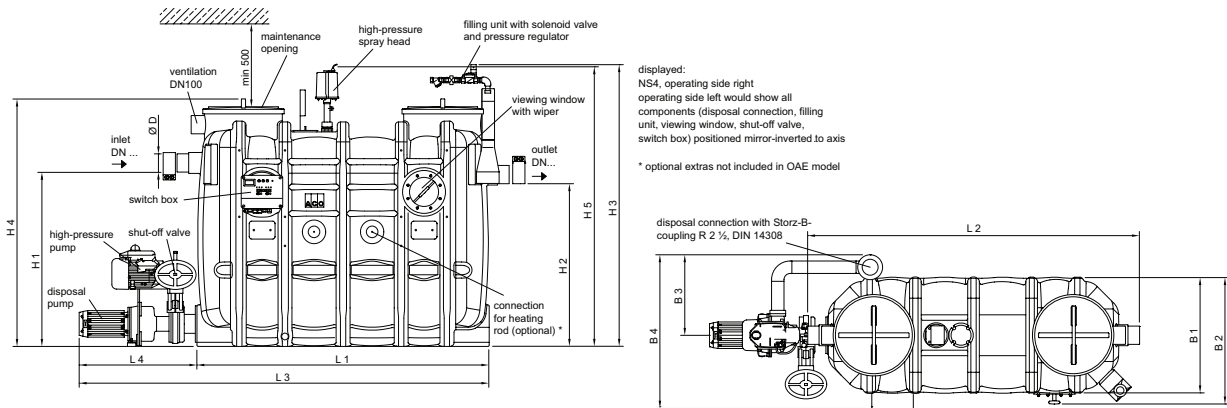

Nominal size	Spigot nominal size	Sludge storage volume (l)	Grease storage volume (l)	Total capacity (l)	Dry Weight (kg)	Full Weight (kg)	Product Ref Left Hand	Product Ref Right Hand
NS 1	DN 100	106	100	320	177	497	3551.84.42	3551.84.32
NS 2	DN 100	210	100	440	182	622	3552.84.42	3552.84.32
NS 3	DN 100	300	150	630	194	824	3553.84.42	3553.84.32
NS 4	DN 100	400	200	830	210	1040	3554.84.42	3554.84.32
NS 5.5	DN 150	725	360	1430	286	1716	3555.84.42	3555.84.32
NS 7	DN 150	800	400	1600	305	1905	3557.84.42	3557.84.32
NS 8.5	DN 150	940	475	1900	325	2225	3558.84.42	3558.84.32
NS 10	DN 150	1000	520	2000	337	2337	3560.84.42	3560.84.32

Nominal size	Dimensions (mm)														Product Ref Left Hand	Product Ref Right Hand
	L1	L2	L3	L4	H1	H2	H3	H4	H5	B1	B2	B3	B4	ØD		
NS 1	1100	1300	1800	700	830	760	1480	1300	1500	700	770	500	930	110	3551.84.42	3551.84.32
NS 2	1100	1300	1800	700	1055	985	1680	1500	1700	700	770	500	930	110	3552.84.42	3552.84.32
NS 3	1450	1650	2150	700	1055	985	1680	1500	1700	700	770	500	930	110	3553.84.42	3553.84.32
NS 4	1760	2000	2460	700	1055	985	1680	1500	1700	700	770	500	930	110	3554.84.42	3554.84.32
NS 5.5	1760	2000	2460	700	1250	1180	1880	1700	1900	950	1020	625	1180	160	3555.84.42	3555.84.32
NS 7	1960	2200	2660	700	1250	1180	1880	1700	1900	950	1020	625	1180	160	3557.84.42	3557.84.32
NS 8.5	2250	2485	2950	700	1250	1180	1880	1700	1900	950	1020	625	1180	160	3558.84.42	3558.84.32
NS 10	2450	2690	3150	700	1250	1180	1880	1700	1900	950	1020	625	1180	160	3560.84.42	3560.84.32

Accessories

- For all accessories please refer to page 43



ACO ROUND ECO-JET-R and HYDROJET-R Series

Product Details

- ECO-JET-R and the more sophisticated HYDROJET-R round grease separators are manufactured from corrosion resistant high-density polyethylene for use inside buildings that are free from frost.
- This range of separators is also available in stainless steel. Contact the ACO Building Drainage Team on 01462 816666 or email abinfo@aco.co.uk for further details.
- Easily upgraded in various stages to more advanced models to suit operational requirements.
- Rugged and durable lightweight corrosion resistant high-density polyethylene construction
- Multi-part construction quickly dismantles for installation in areas with limited access
- Available up to Nominal Size 20 for large catering establishments

ECO-JET nomenclature

- R – Round – basic model
- RD – As R with direct suction facility

HYDROJET nomenclature

- RS – Direct suction and high pressure internal cleaning under manual control. Grease inspection window
- RSE – As RS with manually controlled disposal pump
- RA – As RS but with automatic program control
- RAE – As RA but with disposal pump under automatic control

Plan View

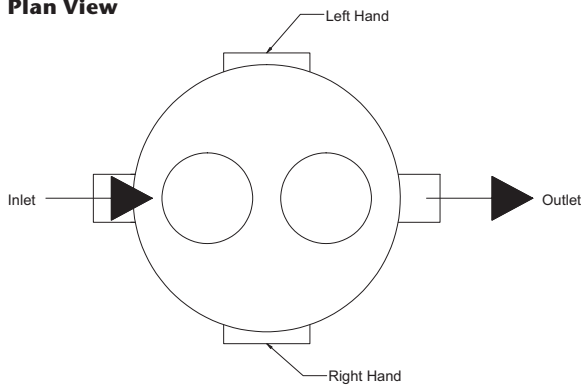

Note – disposal pump required when vertical suction lift exceeds 6m.

Separators fitted with a viewing window can be either right hand or left hand operation and is defined in the diagram below.



Installation example shows HYDROJET RAE grease separator

ACO ECO-JET R (Basic Model) - Technical Data



Product Details

- Disposal and cleaning via open lid (potential odour emissions)
- Upgradeable to Stages 1 to 3

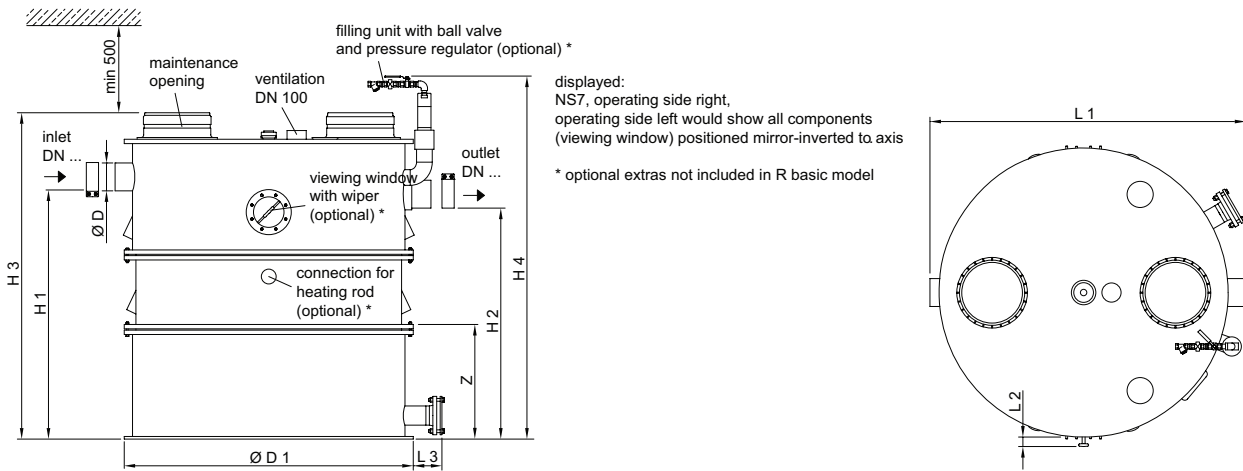

Nominal size	Spigot nominal size	Sludge storage volume (l)	Grease storage volume (l)	Total capacity (l)	Dry Weight (kg)	Full Weight (kg)	Product Ref
NS 2	DN 100	290	120	680	119	799	3502.32.30
NS 4	DN 100	500	160	890	134	1024	3504.32.30
NS 7	DN 150	830	400	2120	301	2521	3507.32.30
NS 10	DN 150	1150	400	2450	311	2761	3510.32.30
NS 15	DN 200	1950	800	3610	357	3967	3515.32.30
NS 20	DN 200	2440	800	4070	358	4428	3520.32.30

Nominal size	Dimensions (mm)										Product Ref
	L1	L2	L3	H1	H2	H3	H4	ØD	ØD1	Z/n	
NS 2	1255	60	170	975	905	1320	1520	110	1150	795/2	3502.32.30
NS 4	1255	60	170	1240	1170	1580	1780	110	1150	820/2	3504.32.30
NS 7	1820	60	170	1430	1330	1880	2080	160	1660	785/3	3507.32.30
NS 10	1820	60	170	1600	1500	2050	2250	160	1660	785/3	3510.32.30
NS 15	2130	60	170	1765	1665	2200	2400	200	1920	880/3	3515.32.30
NS 20	2130	60	170	1955	1855	2400	2600	200	1920	880/3	3520.32.30

Z = largest separate component (mm) / n = number of separable components

Accessories

- For all accessories please refer to page 43



ACO ECO-JET RD Extention Stage 1 - Technical Data



Product Details

- Odour-free contents disposal via direct suction pipe
- Manual internal cleaning via open lid (minor odour emissions)
- Upgradeable to Stages 2 and 3

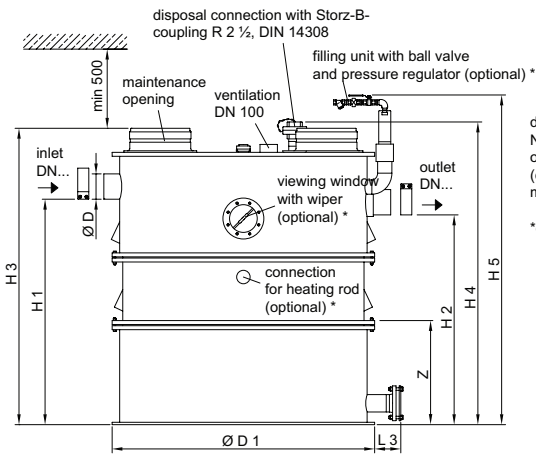

displayed:
NS7, operating side right
operating side left would show all components
(disposal connection, viewing window) positioned
mirror-inverted to axis

*optional extras not included in RD model

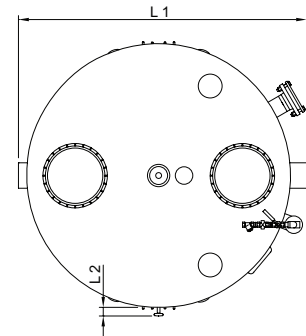

Nominal size	Spigot nominal size	Sludge storage volume (l)	Grease storage volume (l)	Total capacity (l)	Dry Weight (kg)	Full Weight (kg)	Product Ref
NS 2	DN 100	290	120	680	123	803	3502.62.30
NS 4	DN 100	500	160	890	139	1029	3504.62.30
NS 7	DN 150	830	400	2120	310	2430	3507.62.30
NS 10	DN 150	1150	400	2450	321	2771	3510.62.30
NS 15	DN 200	1950	800	3610	358	3968	3515.62.30
NS 20	DN 200	2440	800	4070	360	4430	3520.62.30

Nominal size	Dimensions (mm)										Product Ref
	L1	L2	L3	H1	H2	H3	H4	ØD	ØD1	Z/n	
NS 2	1255	60	170	975	905	1320	1520	110	1150	795/2	3502.62.30
NS 4	1255	60	170	1240	1170	1580	1780	110	1150	820/2	3504.62.30
NS 7	1820	60	170	1430	1330	1880	2080	160	1660	785/3	3507.62.30
NS 10	1820	60	170	1600	1500	2050	2250	160	1660	785/3	3510.62.30
NS 15	2130	60	170	1765	1665	2200	2400	200	1920	880/3	3515.62.30
NS 20	2130	60	170	1955	1855	2400	2600	200	1920	880/3	3520.62.30

Z = largest separate component (mm) / n = number of separable components

Accessories

- For all accessories please refer to page 43

ACO ECO-JET RS Extention Stage 2 - Technical Data



Product Details

- Manually controlled odour-free contents disposal and cleaning via direct suction and high pressure (175 bar) internal cleaning system
- Supplied with viewing window and manually operated ball valve for clean water fill
- Upgradeable to Stage 3

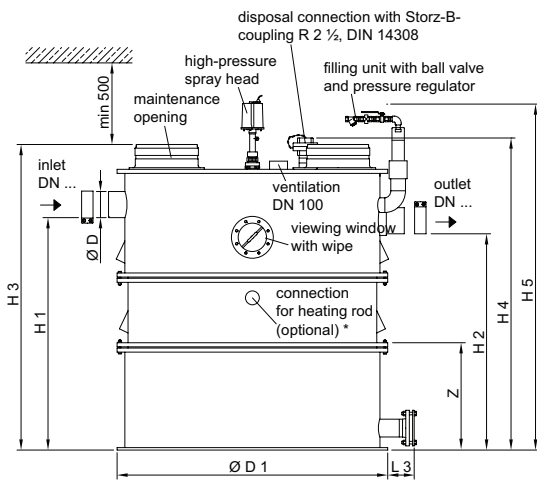

displayed:
NS7, operating side right
operating side left would show all components
(disposal connection, viewing window, high-pressure pump) positioned mirror-inverted to axis.

* optional extras not included in RS model

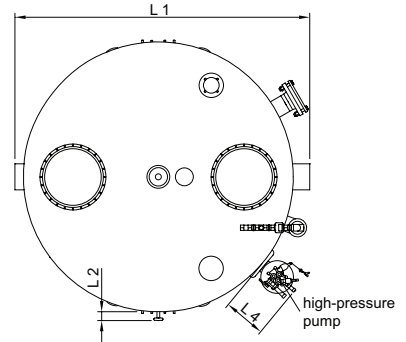

Nominal size	Spigot nominal size	Sludge storage volume (l)	Grease storage volume (l)	Total capacity (l)	Dry Weight (kg)	Full Weight (kg)	Product Ref Left Hand	Product Ref Right Hand
NS 2	DN 100	290	120	680	156	836	3502.73.41	3502.73.31
NS 4	DN 100	500	160	890	172	1062	3504.73.41	3504.73.31
NS 7	DN 150	830	400	2120	344	2464	3507.73.41	3507.73.31
NS 10	DN 150	1150	400	2450	355	2805	3510.73.41	3510.73.31
NS 15	DN 200	1950	800	3610	391	4001	3515.73.41	3515.73.31
NS 20	DN 200	2440	800	4070	392	4462	3520.73.41	3520.73.31

Nominal size	Dimensions (mm)											Product Ref Left Hand	Product Ref Right Hand	
	L1	L2	L3	L4	H1	H2	H3	H4	H5	ØD	ØD1			Z/n
NS 2	1255	60	170	260	975	905	1320	1370	1520	110	1150	795/2	3502.73.41	3502.73.31
NS 4	1255	60	170	260	1240	1170	1580	1630	1780	110	1150	820/2	3504.73.41	3504.73.31
NS 7	1820	60	170	260	1430	1330	1880	1930	2080	160	1660	785/3	3507.73.41	3507.73.31
NS 10	1820	60	170	260	1600	1500	2050	2100	2250	160	1660	785/3	3510.73.41	3510.73.31
NS 15	2130	60	170	260	1765	1665	2200	2250	2400	200	1920	880/3	3515.73.41	3515.73.31
NS 20	2130	60	170	260	1955	1855	2400	2450	2600	200	1920	880/3	3520.73.41	3520.73.31

Z = largest separate component (mm) / n = number of separable components

Accessories

- For all accessories please refer to page 43



ACO HYDROJET RSE Extention Stage 2 - Technical Data



Product Details

- As HYDROJET RS with manually controlled disposal pump (required when vertical height exceeds 6 metres)
- Upgradeable to Stage 3

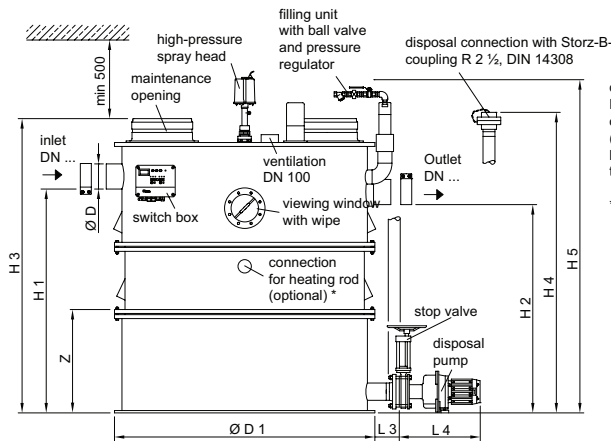

displayed:
NS7, operating side right,
operating side left would show all component
(disposal connection, switch box, viewing window,
high-pressure pump) positioned mirror-inverted
to axis.

* optional extras not included in RS models

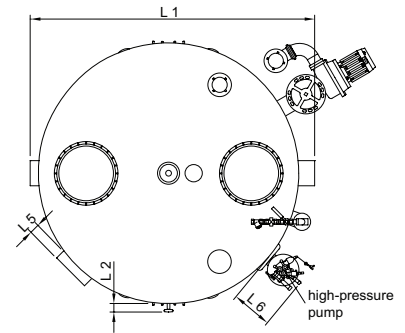

Nominal size	Spigot nominal size	Sludge storage volume (l)	Grease storage volume (l)	Total capacity (l)	Dry Weight (kg)	Full Weight (kg)	Product Ref Left Hand	Product Ref Right Hand
NS 2	DN 100	290	120	680	189	869	3502.73.81	3502.73.71
NS 4	DN 100	500	160	890	205	1095	3504.73.81	3504.73.71
NS 7	DN 150	830	400	2120	377	2497	3507.73.81	3507.73.71
NS 10	DN 150	1150	400	2450	388	2838	3510.73.81	3510.73.71
NS 15	DN 200	1950	800	3610	424	4034	3515.73.81	3515.73.71
NS 20	DN 200	2440	800	4070	437	4507	3520.73.81	3520.73.71

Nominal size	Dimensions (mm)													Product Ref Left Hand	Product Ref Right Hand	
	L1	L2	L3	L4	L5	L6	H1	H2	H3	H4	H5	Ø D	Ø D1			Z/n
NS 2	1255	60	150	520	65	260	975	905	1320	1370	1520	110	1150	795/2	3502.73.81	3502.73.71
NS 4	1255	60	150	520	65	260	1240	1170	1580	1630	1780	110	1150	820/2	3504.73.81	3504.73.71
NS 7	1820	60	150	520	65	260	1430	1330	1880	1930	2080	160	1660	785/3	3507.73.81	3507.73.71
NS 10	1820	60	150	520	65	260	1600	1500	2050	2100	2250	160	1660	785/3	3510.73.81	3510.73.71
NS 15	2130	60	150	520	65	260	1765	1665	2200	2250	2400	200	1920	880/3	3515.73.81	3515.73.71
NS 20	2130	60	150	520	65	260	1955	1855	2400	2450	2600	200	1920	880/3	3520.73.81	3520.73.71

Z = largest separate component (mm) / n = number of separable components

Accessories

- For all accessories please refer to page 43



ACO HYDROJET RA Extention Stage 3 - Technical Data



Product Details

- Programme controlled odour-free disposal and cleaning via direct suction and high pressure (175 bar) internal cleaning system
- Supplied with viewing window and automatically operated solenoid valve for clean water fill
- Upgradeable with disposal pump

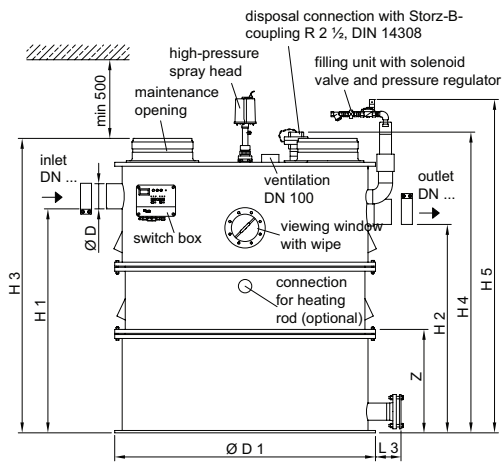

displayed:
NS7, operating side right
operating side left would show all components
(disposal connection, switch box, sight glass,
high-pressure pump) positioned mirror-inverted
to axis.

* optional extras not included in RA model

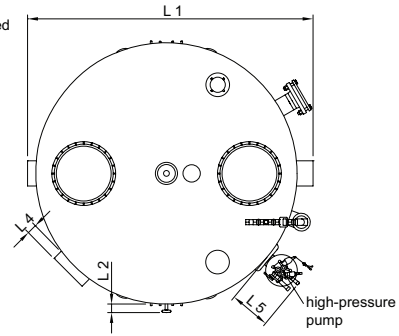

Nominal size	Spigot nominal size	Sludge storage volume (l)	Grease storage volume (l)	Total capacity (l)	Dry Weight (kg)	Full Weight (kg)	Product Ref Left Hand	Product Ref Right Hand
NS 2	DN 100	290	120	680	165	845	3502.73.42	3502.73.32
NS 4	DN 100	500	160	890	181	1071	3504.73.42	3504.73.32
NS 7	DN 150	830	400	2120	353	2473	3507.73.42	3507.73.32
NS 10	DN 150	1150	400	2450	364	2814	3510.73.42	3510.73.32
NS 15	DN 200	1950	800	3610	401	4011	3515.73.42	3515.73.32
NS 20	DN 200	2440	800	4070	401	4471	3520.73.42	3520.73.32

Nominal size	Dimensions (mm)													Product Ref Left Hand	Product Ref Right Hand
	L1	L2	L3	L4	L5	H1	H2	H3	H4	H5	ØD	ØD1	Z/n		
2	1255	60	170	65	260	975	905	1320	1370	1520	110	1150	795/2	3502.73.42	3502.73.32
4	1255	60	170	65	260	1240	1170	1580	1630	1830	110	1150	820/2	3504.73.42	3504.73.32
7	1820	60	170	65	260	1430	1330	1880	1930	2130	160	1660	785/3	3507.73.42	3507.73.32
10	1820	60	170	65	260	1600	1500	2050	2100	2300	160	1660	785/3	3510.73.42	3510.73.32
15	2130	60	170	65	260	1765	1665	2200	2250	2450	200	1920	880/3	3515.73.42	3515.73.32
20	2130	60	170	65	260	1955	1855	2400	2450	2650	200	1920	880/3	3520.73.42	3520.73.32

Z = largest separate component (mm) / n = number of separable components

Accessories

- For all accessories please refer to page 41



ACO HYDROJET RAE Extension Stage 3 - Technical Data



Product Details

- As HYDROJET RA with automatically actuated disposal pump (required when vertical height exceeds 6 metres)

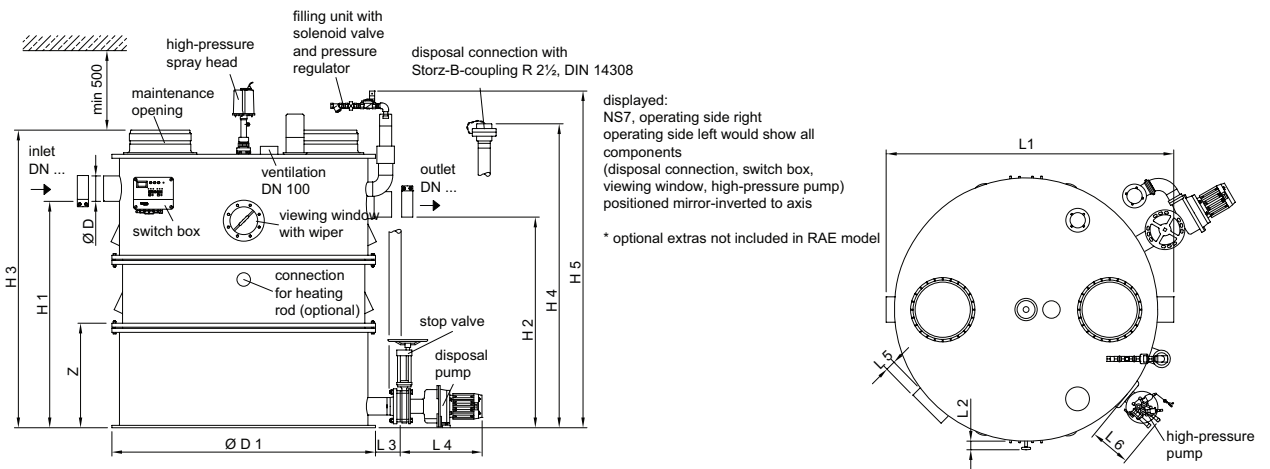

Nominal size	Spigot nominal size	Sludge storage volume (l)	Grease storage volume (l)	Total capacity (l)	Dry Weight (kg)	Full Weight (kg)	Product Ref Left Hand	Product Ref Right Hand
NS 2	DN 100	290	120	680	194	874	3502.73.82	3502.73.72
NS 4	DN 100	500	160	890	210	1100	3504.73.82	3504.73.72
NS 7	DN 150	830	400	2120	382	2502	3507.73.82	3507.73.72
NS 10	DN 150	1150	400	2450	393	2843	3510.73.82	3510.73.72
NS 15	DN 200	1950	800	3610	442	4052	3515.73.82	3515.73.72
NS 20	DN 200	2440	800	4070	443	4513	3520.73.82	3520.73.72

Nominal size	Dimensions (mm)											ØD	ØD1	Z/n	Product Ref Left Hand	Product Ref Right Hand
	L1	L2	L3	L4	L5	L6	H1	H2	H3	H4	H5					
2	1255	60	150	520	65	260	975	905	1320	1370	1570	110	1150	795/2	3502.73.82	3502.73.72
4	1255	60	150	520	65	260	1240	1170	1580	1630	1830	110	1150	820/2	3504.73.82	3504.73.72
7	1820	60	150	520	65	260	1430	1330	1880	1930	2130	160	1660	785/3	3507.73.82	3507.73.72
10	1820	60	150	520	65	260	1600	1500	2050	2100	2300	160	1660	785/3	3510.73.82	3510.73.72
15	2130	60	150	520	65	260	1765	1665	2200	2250	2450	200	1920	880/3	3515.73.82	3515.73.72
20	2130	60	150	520	65	260	1955	1855	2400	2450	2650	200	1920	880/3	3520.73.82	3520.73.72

Z = largest separate component (mm) / n = number of separable components

Accessories

- For all accessories please refer to page 43



ACO ECO-JET and HYDROJET - Accessories

Product	Description	Dimensions	Weight (kg)	Product Ref
	Sampling Pot Polyethylene for installation in horizontal pipe runs. For use with all ACO ECOJET and HYDROJET separators.	DN 100 for separators NS 1 to 4	7.1	3300.09.11
		DN 150 for separators NS 5.5 to 10	7.4	3300.09.21
		DN 200 for separators NS 15 and 20	7.2	3300.09.31
	Sampling Pot Polyethylene for installation in vertical pipe runs. For use with all ACO ECOJET and HYDROJET separators.	DN 100 for separators NS 1 to 4	7.1	3300.10.11
		DN 150 for separators NS 5.5 to 10	7.4	3300.10.21
		DN 200 for separators NS 15 and 20	7.2	3300.10.31
	Pre Strainer Polyethylene body with stainless steel basket for installation in horizontal pipe runs.	DN 100 for separators NS 1 to 4	13.9	3667.00.04
		DN 150 for separators NS 5.5 to 10	14.2	3667.00.05
		DN 200 for separators NS 15 and 20	14	3667.00.06
	Viewing window With window wiper, for checking thickness of grease layer	For use with all ACO ECOJET and HYDROJET separators.	5	3300.11.10
	Manual filling unit Separator filling unit for connection to clean water supply. Manually operated ball valve.	For use with ACO ECO-JET O and R	3.5	3300.11.22
		For use with ACO ECO-JET G and GD	9.7	0153.06.76
	Remote control unit IP54 rated remote control unit. Customer to supply 7 x 10mm ² cable.	For use with ACO HYDROJET OA and RA	2	0150.02.86
		For use with ACO HYDROJET OAE and RAE	2	0150.03.40



Bespoke Pumping Station Solutions

Application example - kitchen waste water pipe invert below separator inlet

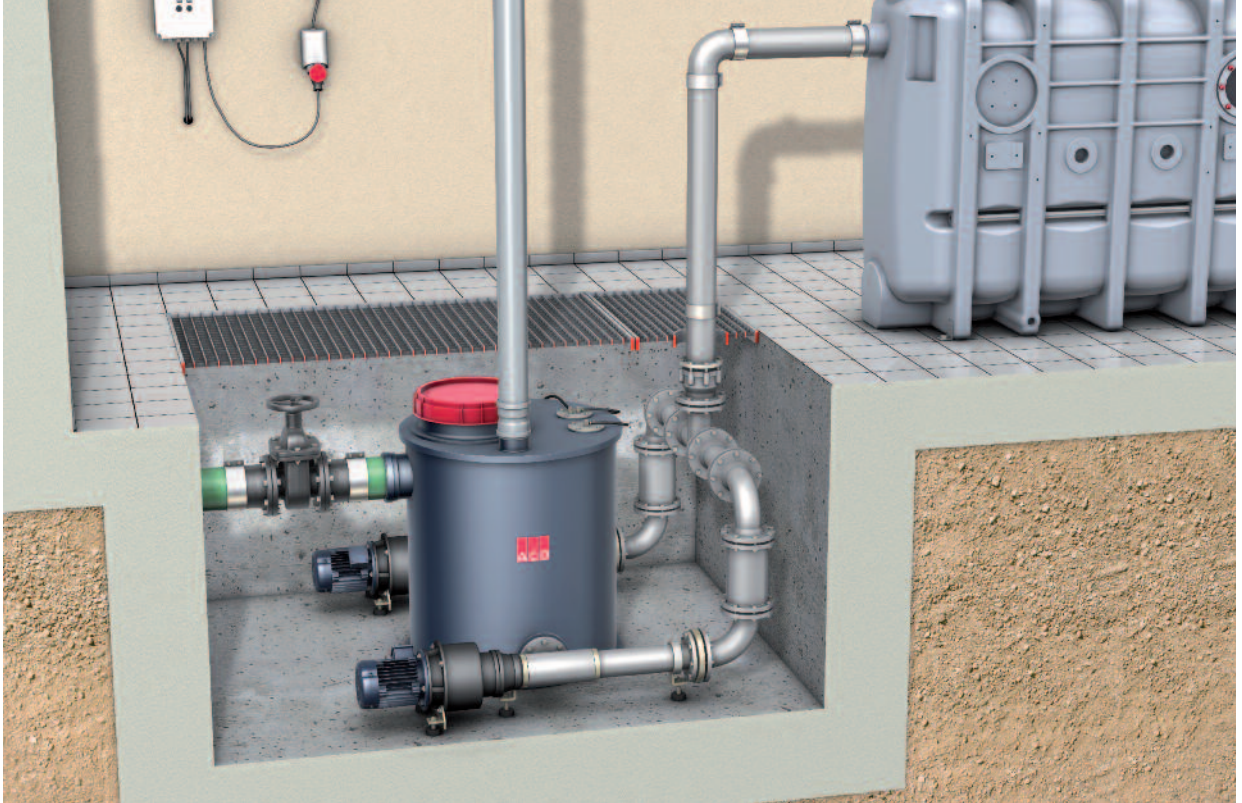

For some applications where the kitchen or food preparation area is located on the ground floor or in the basement of a building, it may not be possible to connect kitchen waste water to a gravity grease separator in the conventional manner because the inlet to the separator is above the waste water pipe from the kitchen.

For this type of application, dedicated plant is required to pump the waste water into the separator. Conventional lifting stations are not suitable for this up-stream pumping application because the pump action will create turbulence of the waste water fluid and create emulsions that will be difficult to separate efficiently.

The solution is to fit a positive displacement pumping station to deliver the waste water into the separator.

ACO positive displacement pumping stations are configured into an up-stream buffer tank manufactured from polyethylene or stainless steel that collects the incoming waste water from the kitchen or food preparation area.

A pneumatic pressure switch installed in the buffer tank is triggered when the waste water reaches a pre-determined level and activates the positive displacement pump to deliver the waste water to the separator without detrimental turbulence. The pumps used by ACO for this application are not affected by grease.

All up-stream positive displacement pumping stations are custom made for each project. Contact the ACO Building Drainage Helpline on 01462 816666 for further assistance.

ACO Pipe® Stainless Steel Pipe Systems

As part of a growing range of engineered drainage solutions, ACO PIPE® presents a wide range of socketed waste pipework systems in thin-wall stainless steel for above and below ground drainage applications that is ideal for connecting ACO grease separators.

ACO PIPE® is reliable, lightweight and a durable push-fit pipework system, designed, produced and tested for soil, waste, rainwater and industrial wastewater drainage applications.

ACO PIPE® stainless steel pipework systems are manufactured from austenitic stainless steel in grades 304 and 316. All products are chemically pickled passivated for optimum durability and corrosion resistance.

Used together with other ACO products it creates a perfect system and offers a sustainable drainage solution with unique advantages to the customers. When used with ACO gullies and ACO stainless steel channel systems it provides a unique system for building drainage. The push-fit system ensures quick and easy assembly for a reliable installation for gravity and vacuum drainage.

All ACO PIPE® interconnecting seals and fittings incorporate a unique double sealing system providing a trouble-free, reliable sealing system – every time.

More than 1,500 different products are available (straight pipes, bends, branches, diameter increasers and reducer's) and together with a wide range of accessories this creates a complex and complete system for pipework construction.

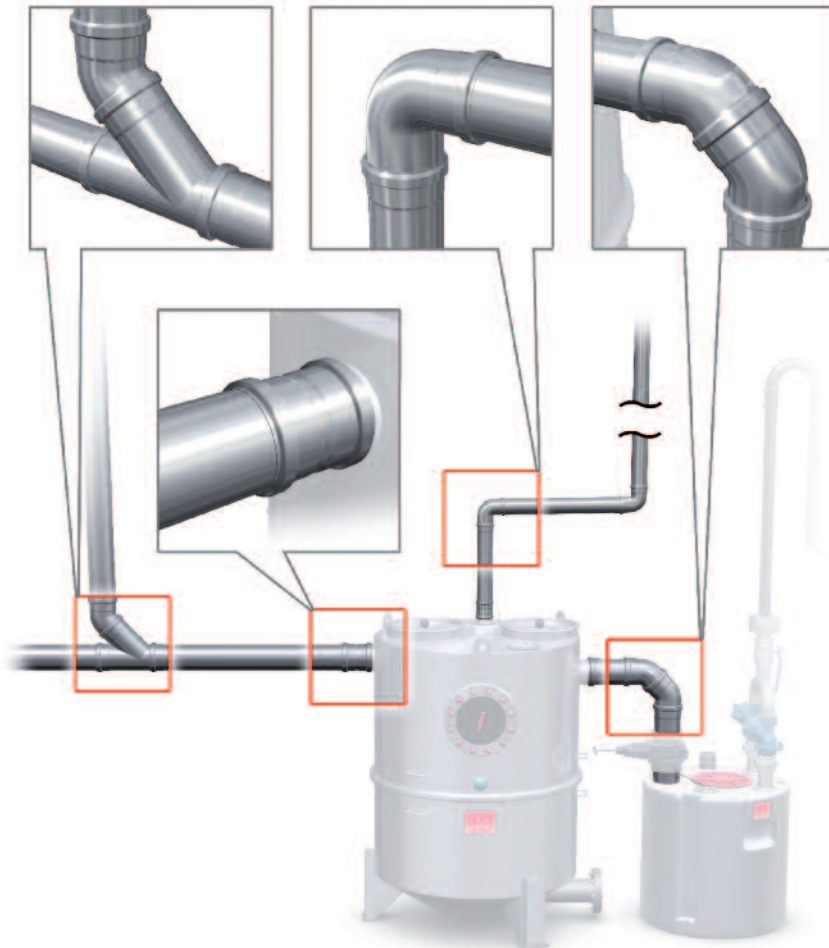

Typical applications

ACO PIPE® stainless steel pipe is the fast track alternative to cast iron or PVC-u pipe systems and is available in standard and non-standard pipe sizes with easy to assemble push-on fittings. ACO PIPE® is ideal for:

- Food processing plants
- Commercial buildings
- Chemical processing plant
- Industrial buildings
- Hotels
- Kitchens
- Leisure centres
- Hospitals
- Laboratories
- Schools
- Abattoirs

Product benefits

ACO PIPE® socketed stainless steel systems significantly reduces installation time and associated costs along with long term maintenance and care costs.

- Easy installation
- Highly corrosion resistant
- Lightweight and easy to handle
- Double sealed jointing system
- Simple push-fit assembly
- Low thermal expansion coefficient
- No painting required
- Aesthetically pleasing
- Electro-polished option
- Sustainable material
- Hygienic

ACO Below Ground Separators

ACO Lipumax P - Installation Recommendations

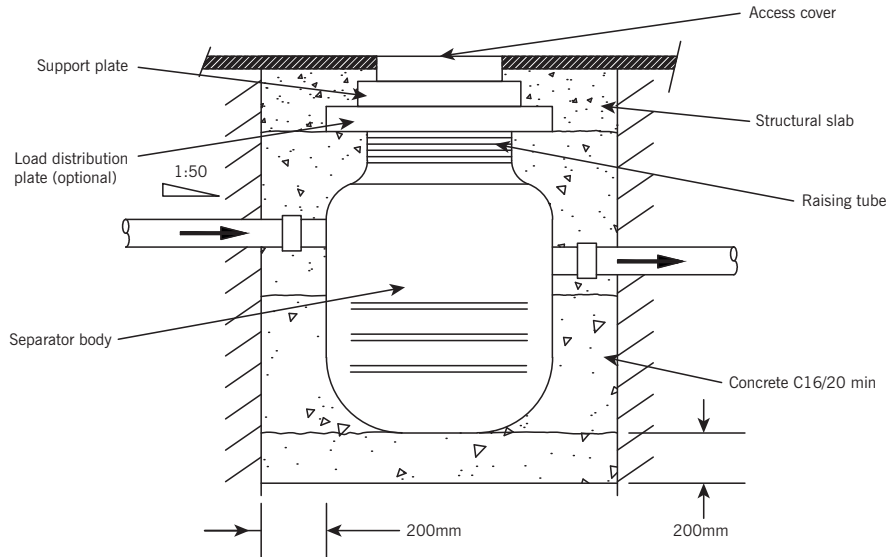

1. These recommendations assume the unit is to be installed with a concrete backfill. Alternative detail for light duty applications to engineers' detail. Ensure the requirements for the particular site conditions are met, including avoidance of tank floatation taking engineering advice where necessary.
2. Confirm Load Class of application and concrete slab specification together with any associated reinforcement detail to prevent in-service wheel loads from being directly transferred to the raising tube/separator body. Assess inlet invert position allowing an incline of the inlet pipe of at least 1:50 (2%) to prevent grease build up as per BS EN 1825 Part 2. Do not fit the raising tube or the optional load distribution plate yet.
3. Excavate a hole to receive the unit, raising tube and access cover allowing for a minimum of 200mm thickness of concrete below and around the unit with sufficient working space for connection of pipework and vents as required. Any unsuitable ground is to be removed and replaced. Engineering advice may be necessary. The excavation is to be kept free of water.
4. All concrete used in the installation is to be of minimum C16/20. Where necessary, a higher specification of concrete may be

required. Engineering advice should be sought. Prevent ingress of detritus into separator body at all times. Pour a minimum 200mm thickness of concrete onto the base of the excavation, and whilst the concrete is still wet, carefully lower the separator unit onto the concrete using appropriate slings.

Check the unit is fully supported by the concrete, level and the correct height and orientation noting flow direction. Allow the concrete to harden.

5. Add 500mm depth of clean water to the inside of the unit. Carefully place additional concrete to the sides of the unit to a level of between 400mm and 500mm above the base of the unit. Do not use vibrating pokers. Check the unit is still correctly positioned and level. Allow this concrete to harden.
6. Add clean water to the invert of the outlet pipe. Carefully place additional concrete to the sides of the unit to a level just below the outlet pipe level ensuring there is sufficient space for the connection of the pipework. Allow this concrete to harden.
7. Connect inlet, outlet and vent pipework as required. Connect direct suction line if applicable.

8. Taking into account the access cover and support plate thickness, trim raising tube to suit the finished slab level as required, reposition the seal to the first rib above the cut surface, lubricate with grease and assemble to separator body. Apply concrete to level 'A' for Load Class B125 and 'B' for Load Class D400 applications to ensure any wheel loads applied through access cover are not transmitted to the raising tube or separator body. Allow this concrete to harden.

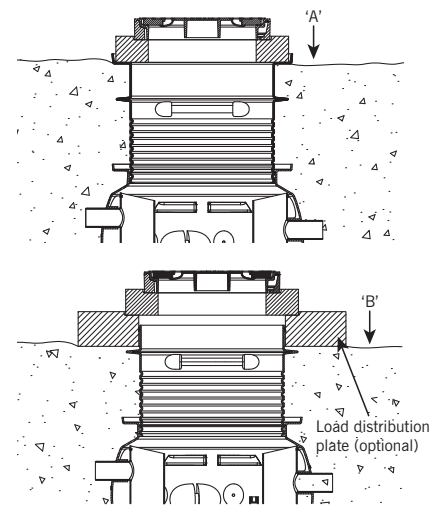

9. Carefully position concrete load distribution plate (if applicable), concrete adaptor plate and access cover and complete installation to finished slab level.

ACO Below Ground Separators

ACO ECO-FPI - Installation Recommendations

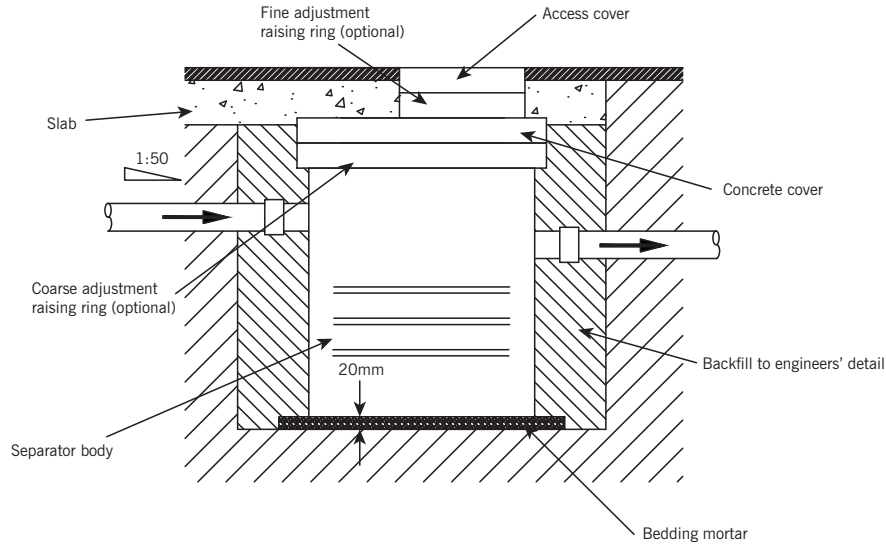

1. The ECO-FPI grease separator is a load bearing structural unit and may be installed without concrete backfill if required. Ensure the requirements for the particular site conditions are met, including avoidance of tank floatation taking engineering advice where necessary.

For installations where the water table is at least one metre above the base of the separator, optional integrated baseplate reinforcement may be required to withstand the hydrostatic pressure. Baseplate reinforcement is only available as a factory fitted option.
2. Use of fine and coarse adjustment rings. Access cover raising rings are not supplied with seals. Interconnecting joints require a bed of mortar during assembly for airtight operation. For stability during installation, a maximum of three access cover raising rings should be used. Additional inlet invert depths can be achieved with combinations of coarse and fine raising rings.
3. Assess inlet invert position allowing an incline of the inlet pipe of at least 1:50 (2%) to prevent grease build up as per BS EN 1825 Part 2.

Excavate a hole to receive the complete unit including the concrete cover, access cover and any coarse/fine raising rings allowing for a minimum of 20mm thickness of levelling mortar below the unit with sufficient working space for connection of pipework and vents as required. Any unsuitable ground is to be removed and replaced. Engineering advice may be necessary. The excavation is to be kept free of water.
4. Prevent ingress of detritus into separator body at all times. Prepare a lean mix levelling mortar approximately 20mm thick to bed the separator. Lower the separator body on to the mortar bed checking level, correct height and orientation noting flow direction using appropriate slings. Make inlet and outlet pipe connections.
5. Fill the separator with clean water to test pipe joints and assist stabilisation.
6. Lower optional chamber raising ring(s) on to separator body. Lower concrete cover plate into position ensuring all seals are free from detritus.
7. Fit optional access cover raising ring(s) using a suitable mortar grout between joints.
8. Position access cover ensuring the top is level with the finished slab or a maximum of 3mm below and grout.
9. Backfill to engineers' detail to slab level.
10. Pour slab to engineers' detail.

ACO Free-Standing Separators

ACO ECO-JET and ACO HYDROJET - Installation Recommendations

General notes for all free-standing separators

In the absence of prevailing Local Authority regulations, refer to BS EN 1825 Part 2: Grease Separators - Selection of Nominal Size, Installation, Operation and Maintenance for detailed description of installation requirements.

Place of installation

Separators should be located as close to the FOG source as possible, but should not be located in unventilated rooms, car parks, or storage areas. To prevent odour nuisance, separators should not be located close to habitable buildings, especially to opening windows and air intakes.

Protect the separator and inlet/outlet pipes from frost and ensure adequate space for maintenance and service access.

Note: The Separator should be placed out of direct sunlight.

Drainage to and from the separator

Grease separators are designed to operate with a free-running outlet without backflow.

Separators operating below the backflow/flood level (usually the street level) should be fitted with an appropriate lifting station.

To prevent the build up of fats and grease in pipes upstream of the separator, the inlet pipe should be laid at a minimum gradient of 2% to the separator. Additional measures such as thermal insulation and trace heating may also be required.

Transition from vertical to horizontal inlet pipes may be achieved using two 45° bends between which a length of pipe, at least 250mm long, is placed. This is followed by a stilling section that has a length (in mm) equal to at least 10 times the nominal size of the inlet supply pipe. For example, an inlet pipe size of 110mm, the stilling section should be at least 1100mm long before connection to the separator inlet.

Ventilation

Upstream and downstream pipe connections to the separator must be adequately ventilated. Provide the discharge pipe with a stack vent and provide a branch vent to all upstream branch pipes greater than 5 metres long.

Typical installation schematic

HYDROJET system installed in the basement of a catering establishment. Schematic depicts ancillary equipment and fittings supplied by others

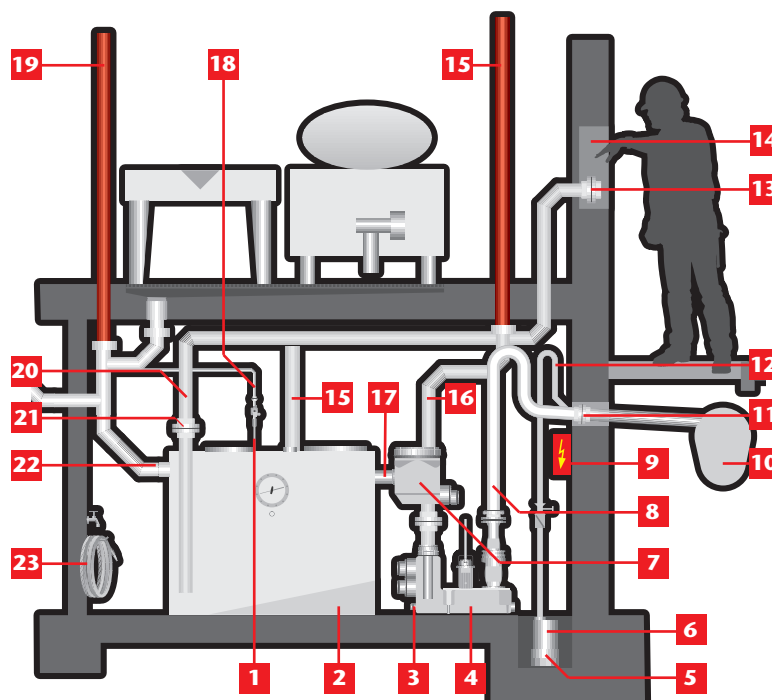

- 1 Clean water fill supply pipe
- 2 Grease separator with direct suction device
- 3 Manual diaphragm pump connection
- 4 Lifting station
- 5 Basement sump
- 6 Basement drainage pump
- 7 Sampling station
- 8 Lifting plant outlet
- 9 Lifting plant controller
- 10 Foul sewer
- 11 Wall seal/bushing
- 12 Backflow loop
- 13 Bauer 3" connector for external servicing
- 14 In-situ wall box for external suction connection
- 15 Separator ventilation (if required)
- 16 Lifting plant ventilation
- 17 Separator outlet/lifting station inlet
- 18 Clean water shut-off valve
- 19 Inlet ventilation
- 20 Direct suction pipe/connections
- 21 Bauer 3" connector
- 22 Separator inlet
- 23 Flexible hose for cleaning purposes

Installation - Free-Standing Separators

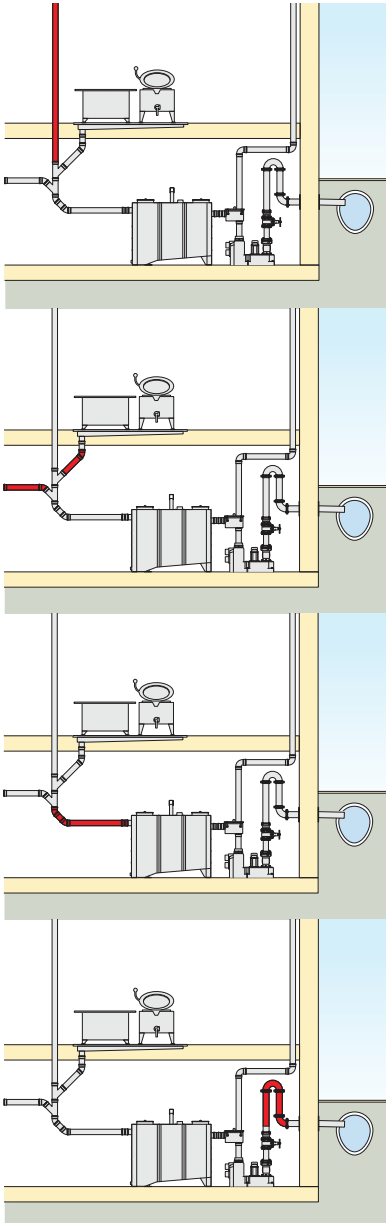

Venting

- Inlet and outlet pipes must be ventilated.
- Vent stack should pass through the roof. Connecting pipes with lengths exceeding 5m require dedicated vent stacks.
- Inlet pipes longer than 10m without intermediate vented connection pipes must be vented at the separator inlet point.

Preventing upstream grease build-up

- Inlet pipes passing through unheated rooms must be thermally insulated.
- Install trace heating on inlet pipes at risk of freezing, i.e. underground car parks.
- No additional measures required in heated rooms or where inlet pipes run in frost-free rooms.

Inlet stabilisation

- Transition to horizontal pipe run into the separator provided with two 45° pipe bends with an intermediate section at least 250mm long. Upstream connection to the separator then via a stilling section whose length in mm is at least x10 the nominal pipe size connection, i.e. DN 100 pipe: $100 \times 10 = 1000\text{mm}$ stilling section.
- Inlet pipe must have a minimum gradient of 2% (1:50).

Backflow loop

- The invert of the backflow loop must be positioned higher than the backflow level.

Lifting stations

- A variety of dual pumped lifting stations are available for all applications where the separator is below the main sewer connection. Contact the ACO Building Drainage Design Services Team on 01462 816666 or email abdtechnical@aco.co.uk for further details.

Useful references:

BS EN 1825 Grease separators - Part 2: Selection of nominal size, installation, operation and maintenance.

BS EN 12056 Gravity drainage systems inside buildings - Part 4: Waste water lifting plants - layout and calculation.

Operation, Maintenance and Accessories

General Information

All Gravity Grease Separators require periodic maintenance to remove the fats, oils and grease (FOGs) together with sludge deposits that have been separated from the waste water. Such maintenance is usually undertaken by a specialist waste contractor.



The frequency of maintenance will depend on the volume of FOGs and the volume of sludge that is generated in the food production process. Sludge volume can be significantly reduced by effective use of strainers on sink outlets.

Note. Only waste water containing organic FOGs should be discharged to a grease separator. Effluent from the following should NOT be connected to the separator:

- Toilets
- Macerators
- Rainwater
- Light liquids e.g. grease or oil of mineral origin

Macerators have the effect of artificially consuming the sludge capacity of the separator and thereby shortening the service interval to the separator. Additionally, under certain conditions, the process of maceration can emulsify waste products and prevent them from separating via the natural gravity process, thereby reducing the separation efficiency of the unit.

Start Up and System

Characterisation

Before using the separator for the first time, fill with clean water. When first commissioned, it is recommended that the separator is emptied, cleaned and refilled ideally every 2 weeks, or on a monthly basis in order to assess volumes of separated matter for that installation.

When the separator is emptied, fill with clean water to immediately allow the separation process to continue. The waste disposal contractor should be able to recommend the optimum servicing frequency.

Thick encrustations of FOG residues can form within the separator body and may therefore require vigorous cleaning methodologies to remove them during the cleaning process.

Disposal

Sludge traps and separators must be completely emptied and cleaned at least once a month, preferably every two weeks. The separators must subsequently be refilled with water (e.g. drinking water, processed water, treated water from the grease separator), which corresponds with the local inlet regulations.

Operating log

An operating log should be maintained for each grease separator. The following should be entered in the log: Completed inspections, maintenance, checks and disposals. The operating logs should be stored by the operator and should be presented to the locally responsible authority upon request.

Maintenance

The separator must be maintained annually by a competent person according to the manufacturer's specifications.



Model Specification Clause

All ACO Building Drainage grease separators are NBS specified products. Assistance in completing this clause can be found in ACO Technologies product entries in NBS Plus or a model specification can be downloaded from www.acobd.co.uk

EU Conformity

All ACO Grease Separators are fully certified to BS EN 1825:2004 and CE marked in accordance with the Construction Products Regulation.

Declarations of Performance are available via our website www.acobd.co.uk or on request, please contact ACO Building Drainage Design Services Team on 01462 816666 for further information.



ACO Technologies plc

- ACO Building Drainage
- ACO Water Management
Civils + Infrastructure
Urban + Landscape
- ACO Sport
- ACO Wildlife



ACO Building Drainage

A division of ACO Technologies plc
ACO Business Centre
Caxton Road
Bedford
Bedfordshire
MK41 0LF
Tel: 01462 816666
Fax: 01462 851490

e-mail: abdinfo@aco.co.uk
www.acobd.co.uk

The ACO Group: A strong family you can depend on.

© August 2013 ACO Technologies plc. All reasonable care has been taken in compiling the information in this document. All recommendations and suggestions on the use of ACO products are made without guarantee since the conditions of use are beyond the control of the Company. It is the customer's responsibility to ensure that each product is fit for its intended purpose, and that the actual conditions of use are suitable. This brochure and any advice is provided by ACO Technologies plc (the Company) free of charge and accordingly on terms that no liability including liability for negligence will attach to the Company or its servants or agents arising out of or in connection with or in relation to this brochure or any such advice. Any goods supplied by the Company will be supplied solely upon its standard conditions of sale, copies of which are available on request. The Company's policy of continuous product development and improvement renders specifications liable to modification. Information provided in this brochure is therefore subject to change without prior notification.